

AGENCY FOR INTERNATIONAL DEVELOPMENT
 WASHINGTON, D. C. 20523
BIBLIOGRAPHIC INPUT SHEET

FOR AID USE ONLY
Batch 72

1. SUBJECT CLASSIFICATION	A. PRIMARY Food production and nutrition	AQ10-1540-0000
	B. SECONDARY Food processing--root vegetables--Cassava	

2. TITLE AND SUBTITLE
 Cassava storage; post-harvest deterioration and storage of fresh cassava roots

3. AUTHOR(S)
 Booth, R.H.

4. DOCUMENT DATE 1975	5. NUMBER OF PAGES 18p.	6. ARC NUMBER ARC
--------------------------	----------------------------	----------------------

7. REFERENCE ORGANIZATION NAME AND ADDRESS
 CIAT

8. SUPPLEMENTARY NOTES (*Sponsoring Organization, Publishers, Availability*)
 (In series EE-16)

9. ABSTRACT

10. CONTROL NUMBER <i>PN-AAE-775</i>	11. PRICE OF DOCUMENT
12. DESCRIPTORS Cassava Deterioration Post harvest Storage	13. PROJECT NUMBER
	14. CONTRACT NUMBER AID/ta-G-1090 GTS
	15. TYPE OF DOCUMENT

Series EE 16
September 1975

Cassava storage

**Post-harvest deterioration and storage
of fresh cassava roots**

R. H. BOOTH

**Centro Internacional de Agricultura Tropical
Cali – Colombia**

TABLE OF CONTENTS

	Page
Introduction	5
Post-harvest deterioration and pertinent storage considerations	6
Storage techniques	8
Storage losses	14
The quality of stored roots	15
Conclusions	17
References cited	18

ACKNOWLEDGEMENTS

My thanks are due to the members of the CIAT cassava team who helped me in this work and to D. G. Coursey of Tropical Products Institute (TPI), who instigated the project and took an active interest as it progressed.

The project was financed by the Ministry of Overseas Development (ODM) of the United Kingdom and was jointly managed by CIAT and TPI. The work on quality was done in cooperation with the Instituto de Investigaciones Tecnológicas (IIT) and the Federación Nacional de Cafeteros.

R. H. BOOTH

INTRODUCTION

Until recently, it was generally accepted that cassava roots could not be kept in a fresh state for more than a few days after harvest. This presents serious problems in the marketing and utilisation of the crop and results in heavy losses. Under the near subsistence farming conditions under which most of the world's cassava is produced, the normal method of overcoming this difficulty is to leave the plants in the ground until needed and once harvested, to utilise the roots immediately or to dry them for longer storage life.

Ingram and Humphries (1972) estimate that although cassava may be harvested over a long period of time, leaving the roots in the ground until required unnecessarily occupies three quarters of a million hectares of agricultural land. Furthermore, losses due to pathogens increase when roots remain in the ground too long. Although the roots may continue to increase in size, they become more fibrous and woody and their content of extractable starch decreases.

The difficulty of holding stocks of fresh roots at a processing plant for even a few days has frequently been a major factor inhibiting increases in the scale of production of dried or processed products. In those areas where cassava is marketed as a fresh vegetable, considerable losses occur at all stages in the marketing chain, especially where the crop is grown at some distance from market outlets.

In order to store fresh cassava roots, it is necessary to understand their post-harvest behaviour. Two essential requirements of any storage system are (1) The product should lose as little weight as possible during storage, and (2) it must be of acceptable quality after storage. The methods developed to meet these requirements should, of course, be devised to yield maximum returns on the investment made, and different techniques should be developed for different circumstances. As most of the world's cassava is produced by the small farmer—frequently under severe economic and organisational constraints—emphasis should be placed on simple, inexpensive techniques.

POST-HARVEST DETERIORATION AND PERTINENT STORAGE CONSIDERATIONS

There is little reliable information available on the rapid post-harvest deterioration of cassava roots; it has been thought to be caused by pathogens and/or physiological reactions.

Primary and secondary deterioration

Two types of deterioration, termed primary and secondary, have been identified (CIAT, 1973, 1974; Booth, 1973). Primary deterioration is usually the initial cause of loss of acceptability of roots and is shown by fine blue-black streaks in the root vascular tissue, which later spread, causing a more general brown discolouration. Secondary deterioration is due to pathogenic rots, fermentation and/or softening of the roots and generally occurs when the roots have already become unacceptable because of primary deterioration. Occasionally, however, secondary deterioration may be the cause of loss of acceptability; and in these cases vascular streaking and tissue discolouration may occur ahead of any advancing rots.

Averre's earlier report (1967), linking vascular streaking with sites of mechanical damage, has been confirmed. It seems that primary deterioration is caused by a wound reaction since symptoms usually develop from sites of cell injury. Symptom development could be delayed by the use of various surface sterilants and fungicides although no microorganisms could be consistently isolated from internally streaked tissue. This suggests that if microorganisms play any part in the reaction, they may be responsible only for initiating or stimulating vascular streaking. Increased moisture loss at these sites may also encourage symptom development.

Mechanical damage

As with all agricultural produce, the success or failure of cassava storage methods depends to a large extent on the condition of the product entering storage. Care should be exercised during harvesting and handling to reduce damage to a minimum, and only the least damaged roots should be selected for storage since severely damaged roots have been shown to deteriorate more rapidly (Booth, 1975).*

Varietal reaction and selection

Montaldo's (1973) observations that cultivars differ considerably in the rate at which primary deterioration occurs have been confirmed with cultivars from the

* Unpublished article

CIAT germplasm collection (Booth: Noon and Kawano, personal communication). Time to onset of deterioration varies from 0 to 7 days, depending on the cultivar. Some cultivars are inherently easier to harvest than others; therefore, differences in times to onset of deterioration may be based on differing amounts of damage inflicted during harvesting, as well as true varietal variation.

If a choice of cultivars exists, those that deteriorate less rapidly and that can be harvested and handled with minimum damage should therefore be selected for storage purposes.

Curing

This technique has been used widely for enhancing the storage life of other root crops, such as potatoes and sweet potatoes, and relies on the fact that at relatively high temperatures and relative humidities, wounds are healed and subsequent deterioration limited. It has been demonstrated (Booth, 1975)* that at 80 to 85 per cent relative humidity and temperatures between 25 and 40°C, suberisation occurs in 1 to 4 days and a new cork layer forms around wounds 3 to 5 days later (Figs. 1 and 2). At 40°C and above, primary deterioration usually takes place before wound healing.

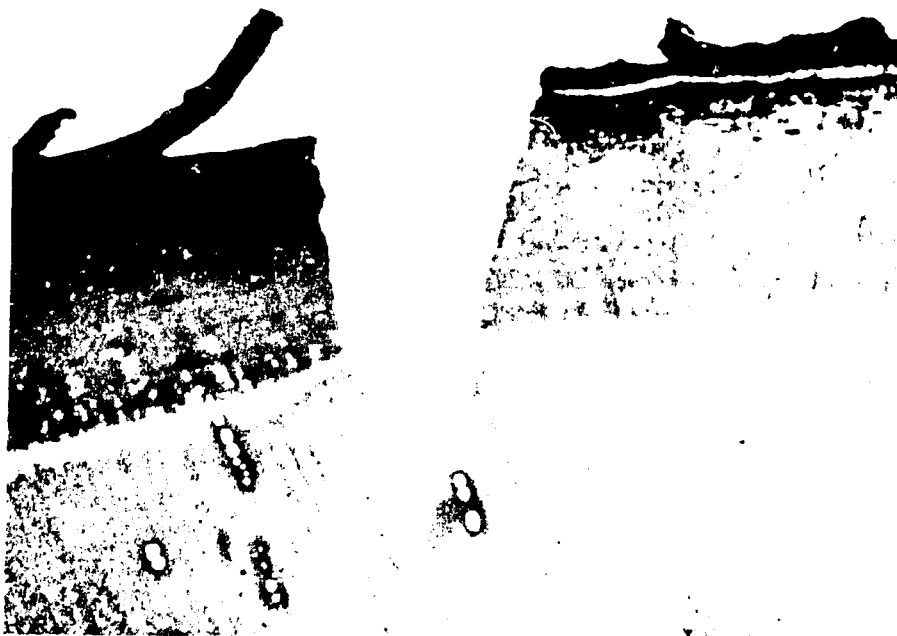

Figure 1. Curing and wound healing of a cassava root: section through a fresh wound.

* Unpublished article



Figure 2. Curing and wound healing of a cassava root: section through a cured wound showing meristem and cork formation.

Curing cassava roots prevents the onset of primary deterioration, reduces secondary deterioration losses by providing a barrier against invasion by wound pathogens, and limits moisture loss.

STORAGE TECHNIQUES

A few instances have been recorded of the successful storage of fresh cassava roots, using high-cost systems such as refrigeration and waxing (Singh and Mathur, 1953; IIT, 1973). Considering the conditions under which much of the world's cassava is grown, such techniques cannot be regarded as being generally applicable at present. Small quantities of roots can be preserved for several days using such simple techniques as reburial, coating in mud, and placing under water. There are a few reports of the successful storage of quantities of cassava for longer periods using simple techniques: e.g., burying the roots in some form of trench or covering them with soil or straw and soil inside a building (Ingram and Humphries, 1972).

It is possible that some of these early successes were due to the roots being placed in conditions conducive to curing. However, it is well known that the conditions required for rapid curing of other root crops may not be optimal for subsequent storage. This is probably true for cassava as well; thus, the post-harvest period should ideally be divided into two principal stages: curing and storage.

When seeking simple storage techniques, it is often necessary to accept a compromise solution and select a method that will allow for both curing and storage and that will provide an acceptable weight of utilisable produce after the required storage period. In the case of cassava, preliminary trials have indicated that successful curing and storage may be achieved by either placing roots in simple field clamps or packing them in boxes with a moist material (Booth and Coursey, 1974).

Field clamp storage

Field storage experiments using structures similar to European potato clamps (Fig. 3) have shown that cassava roots can be cured successfully (Fig. 4) and stored (Fig. 5) for periods of one to three months, depending upon clamp design and prevailing ambient conditions.



Figure 3. Cassava storage clamp.



Figure 4. Cured cassava root after four weeks' storage in a clamp.

The basic design of these field clamps is as follows: a circular bed of straw or other material, such as dried grass or dry sugar cane leaves, (approximately 1.5 metres in diameter and 15.0 centimetres thick, after it has been compacted) is placed on suitable, well-drained ground. The freshly harvested roots are heaped in a conical pile on this straw bed (CIAT, 1975). In trials at CIAT, between 300 and 500 kilograms of unselected roots were used for each unit. (At CIAT, 500 kilograms of roots can be harvested in a day by one man). The pile of roots is then covered with a similar layer of straw and the entire clamp covered with soil to a thickness of 15 centimetres. The soil is then removed from around the circumference of the clamp, forming a drainage ditch (Fig. 3).

At CIAT root recovery from this basic clamp type was generally satisfactory during cool, moist periods; but during hot, dry periods, almost complete loss

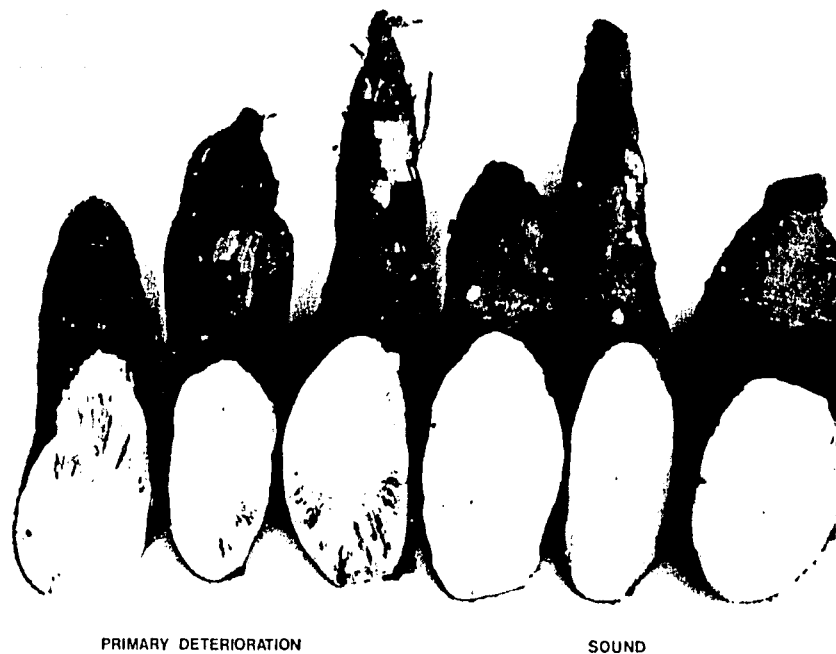

Figure 5. Cassava roots showing no deterioration after eight weeks' storage in a clamp, as compared with roots showing primary deterioration symptoms after three days' storage at ambient conditions.

regularly occurred even after one month's storage. It is necessary, therefore, to modify the design in accordance with the prevailing climatic conditions in a particular area and time.

In hot, dry conditions, it is necessary to ensure that the internal clamp temperature does not exceed 40°C since roots deteriorate rapidly at higher temperatures. The clamp can be altered for these conditions by providing the following modifications: (1) a thicker soil cover to reduce the internal temperature and (2) the provision of ventilators so as to encourage air flow within the clamp (Fig. 6). Ventilators may be constructed from locally available materials, such as straw, hollow bamboo, drainpipes, or timber (Fig. 6). When basal ventilators are used, precautions should be taken to prevent the entry of mice and rats. This can usually be achieved by the use of wire netting; poisons in close proximity to food products should obviously be used with extreme caution.

In very wet conditions, precautions need to be taken to prevent the roots from becoming wet within the clamp since wet roots deteriorate rapidly. Likewise,

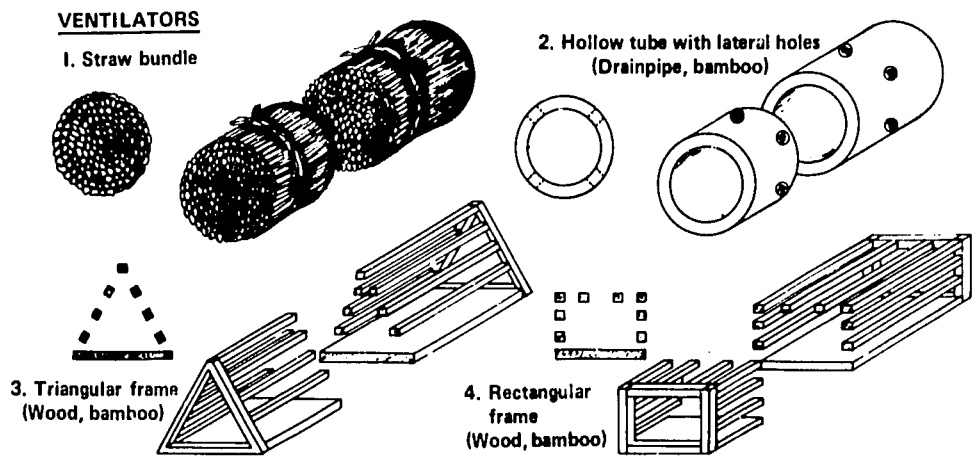
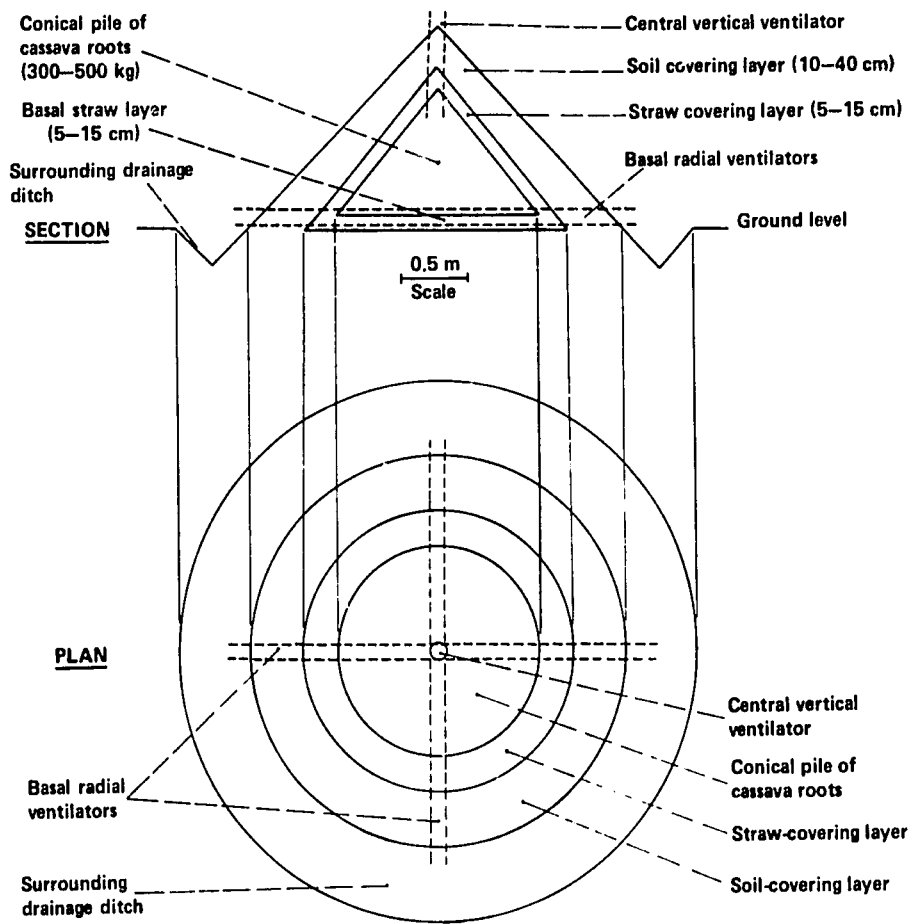

Figure 6. Design of cassava storage clamps.

roots that were rained upon during harvesting and handling should not be stored even if they were subsequently sun dried. Frequent, light rainfall tends to be advantageous after clamp formation, however, since moistening of the soil lowers the internal temperature of the clamp. Therefore, if water is available, wetting the soil cover during hot, dry periods should be considered.

If more than 500 kilograms of roots are to be stored in any one day, it is suggested that several circular clamps or a single elongated structure be built. Roots should not be piled in large round or high mounds to form larger clamps since construction and internal temperature control are more difficult.

Using these modified designs at CIAT in different seasons throughout the year, consistently acceptable recoveries of 75 per cent of the initial weight (or 85 to 90 per cent of the final weight) of roots in marketable condition after one month's storage have been obtained. Additional losses during a second and third month of storage are usually small.

It should be noted that before any specific clamp storage recommendations are made, simple trials using locally available materials in each region need to be undertaken during the required storage season in order to determine the best design and location of clamps, as the time of the year and locality affects their suitability.

Box storage

In the southern United States, the commercial practice of storage in moist sawdust at room temperature was ineffective in controlling vascular streaking and resulted in severe rot (Averre, 1967); nevertheless, this practice has been found extremely effective in storing cassava roots under the ambient conditions prevailing at CIAT.

The method used is as follows: freshly harvested roots are packed with moist sawdust in 20-kilogram boxes. The moisture content of the sawdust packing should be about 50 per cent; this maintains a high relative humidity which promotes curing and prevents excessive moisture loss, but does not wet the roots. If dry sawdust is used, curing does not occur and rapid primary deterioration results; whereas if very moist or wet sawdust is used, excessive secondary root development and rotting frequently occur. Once packed, the boxes can be stored in the shade--for example, in a simple thatched roof shed (Fig. 7)--or in the open, covered by a waterproof tarpaulin. Under the ambient conditions prevailing at CIAT, the internal box temperature was $26^{\circ}\text{C} \pm 2^{\circ}$ when stored in the shade and $30^{\circ}\text{C} \pm 4^{\circ}$ when stored in the open.

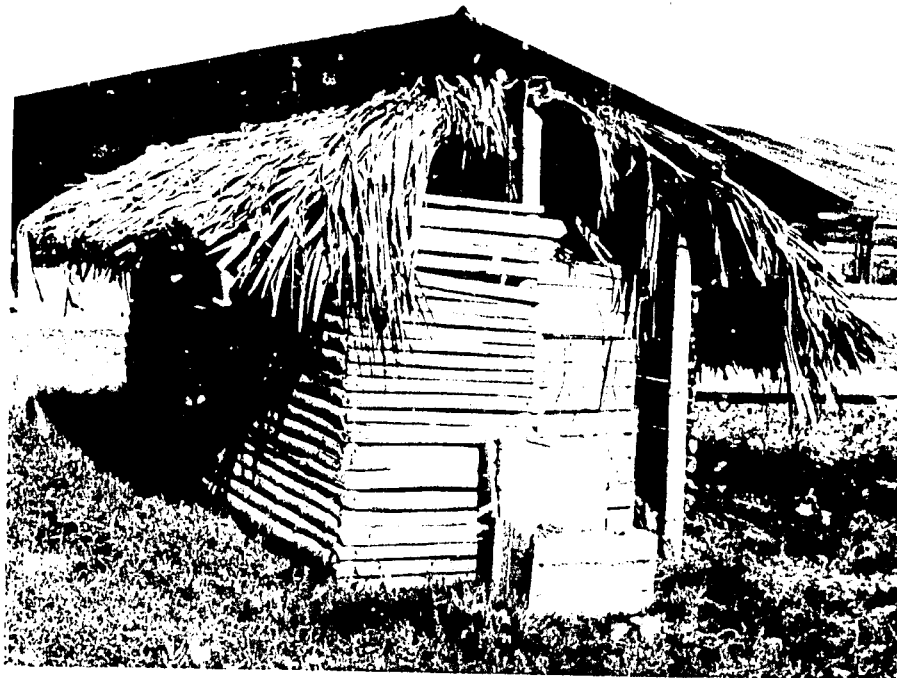

Figure 7. Box and simple shed used for storing cassava roots.

If sawdust is not available, other locally available materials (e.g., coir dust or peat) could be tried. The material used should be moistened sufficiently to maintain the humidity high and to keep the roots fresh without wetting them excessively. Rice husks have not proved to be a very suitable packing material because it is difficult to wet the husks and moisture distribution is uneven. Using freshly harvested, unselected roots, more than 75 per cent and frequently over 85 per cent of the roots are in marketable condition following one month's storage; and only slightly less recovery is obtained after two months' storage (Fig. 8). Again, better results will always be obtained if the roots have little or no damage and are handled with care; a delay in packing after harvest will result in a lower recovery.

In addition to being of direct use to the small producer, this method should also provide a simple handling, transportation and marketing aid, of particular use where the crop is grown some distance from market outlets.

STORAGE LOSSES

As many of the losses during clamp and box storage are a result of secondary deterioration, it is possible that root recovery could be improved by the use of

broad-spectrum fungicides. However, the desirability of post-harvest use of pesticides on food products is highly questionable and is subject to strict legislation in most countries. Before any chemical is added to food products, it should be fully screened and used only in accordance with the manufacturer's recommendations and the food additive regulations of the country concerned. Also, organisational and technical problems often arise regarding suitable application methods and necessary residue testing. For these reasons, it is preferable to seek storage methods that avoid the necessity of using post-harvest pesticides.

THE QUALITY OF STORED ROOTS

Rapid post-harvest deterioration, which normally occurs within a few days of harvesting cassava roots, renders them completely unacceptable for human consumption, reduces their acceptability as animal feed, and lowers the quality of starch obtained from them. As stated above, one of the requirements of any system devised to store fresh cassava roots is that the stored roots be of acceptable quality.



Figure 8. Cassava roots showing no deterioration after eight weeks' storage packed in boxes with moist sawdust.

Following successful curing, cassava roots have a longer shelf life than freshly harvested roots of the same cultivar. However, if cured roots are redamaged, they behave and deteriorate in the same way as fresh roots. If no further damage occurs, the duration of their shelf life is largely determined by moisture loss, the rate of which depends upon prevailing ambient conditions.

A rapid two- or threefold increase in total sugar content of roots, accompanied by a small decline in starch content, has been found to occur within one or two days after harvesting. These carbohydrate levels then remain relatively constant during an eight-week storage period in both field clamps and storage boxes. A slight decline in HCN levels has also been detected during a six- to eight-week storage period. For these reasons, uncooked stored roots consistently taste sweeter and less bitter than freshly harvested roots of the same cultivar.

During an eight-week storage period, a slight softening of the root tissues occurs. After this time, this softening- particularly noticeable in the centre of the, roots- frequently becomes severe, making the roots unacceptable. In spite of this, stored roots require a slightly longer cooking time and frequently have an uneven and slightly harder texture than freshly harvested roots prepared as a fresh vegetable for human consumption.

Nevertheless, the quality of stored roots of a cultivar of excellent eating quality- although not as high as freshly harvested roots- remains acceptable for human consumption for at least an eight-week period. For animal feed purposes, fresh roots and those stored for up to eight weeks are equally acceptable.

CONCLUSIONS

1. Post-harvest deterioration of freshly harvested cassava roots can be classified as (a) primary, when there is internal root streaking and discoloration, which is the initial cause of root unacceptability, and (b) secondary, which is usually caused by a wide range of wound pathogens and normally occurs after primary deterioration.
2. Mechanical damage is a crucial factor in the rapid post-harvest deterioration of cassava roots. Primary deterioration usually commences at the site of cell injury, and the pathogens largely responsible for secondary deterioration usually invade through these harvesting wounds.
3. Cassava cultivars differ considerably, both in the time to the onset of deterioration and in the rate at which this deterioration progresses.
4. When roots are intended for storage purposes, cultivars that have some degree of resistance to post-harvest deterioration and that can be harvested with a minimal degree of root damage should, wherever possible, be selected and only those in good condition used for storage.
5. Like many other root and tuber crops, cassava roots can be cured, during which process wounds are healed and the onset of primary deterioration prevented. Curing takes place in four to nine days at high relative humidities at temperatures between 25° and 40°C.
6. Successful curing and storage of cassava roots for at least two months can be obtained both in storage boxes and in field clamps. The packing material (e.g., sawdust) used in storage boxes should be sufficiently moist to maintain a high humidity and keep the roots fresh without wetting them excessively. It is necessary to determine the most suitable design of field clamp that will maintain the internal temperature below 40°C during any given season.
7. Roots remain of acceptable quality for both human consumption and animal feed purposes for at least eight weeks, and they have a longer shelf life than freshly harvested roots although certain quality changes such as a sweetening and softening of the roots occur during storage.

REFERENCES CITED

- AVERRE, C. W. 1967. Vascular streaking of cassava roots. *In* International Symposium on Tropical Root and Tuber Crops, Trinidad. Proceedings. 2(4): 31-35.
- BOOTH, R.H. 1973. The storage of fresh cassava roots. *In* International Symposium on Tropical Root and Tuber Crops, Ibadan. Proceedings (In press).
- _____ 1974. Post-harvest deterioration of tropical root crops: losses and their control. *Tropical Science* 16(2):49-63.
- _____ and D. G. COURSEY. 1974. Storage of cassava roots and related post-harvest problems. *In* Cassava processing and storage: an interdisciplinary workshop, Pattaya, Thailand. Proceedings. Ottawa. International Research Centre IDRC 31:43-49.
- Centro Internacional de Agricultura Tropical, CIAT. 1973. Cassava production systems: fresh root storage. Annual Report 1972. Cali, Colombia. pp. 74-78.
- _____ 1974. Cassava production systems: fresh root storage. Annual Report 1973. Cali, Colombia. pp. 109-111.
- _____ 1975. Cassava production systems: storage. Annual Report 1974. Cali, Colombia. pp. 99-104.
- INGRAM, J. S. and J. R. O. HUMPHRIES. 1972. Cassava storage: a review. *Tropical Science* 14:131-148.
- Instituto de Investigaciones Tecnológicas, IIT. 1973. La yuca parafinada. *Revista del IIT (Colombia)* 78:131-148.
- MONTALDO, A. 1973. Vascular streaking of cassava root tubers. *Tropical Science* 15(1):39-46.
- SINGH, K. K. and P. B. MATHUR. 1953. Cold storage of tapioca roots. Mysore, India. Central Food Technological Research Institute Bulletin 2(7):181-182.