

USAID NetMark Long Lasting Insecticide Treated Mosquito Nets (LLINs) Production Process



Table of Contents

USAID NetMark LLIN Production Process Executive Summary	1
Introduction	3
Preliminary Research and Target Technology Selection.....	3
Feasibility Trials	4
Laboratory Set-Up	4
Low wet pick-up approach.....	6
Rapid saturation approach.....	7
Example of Wet Pick-Up and Tint Application Trials using the Mist Spray Approach	8
Example of Efficacy of Nets Treated with Deltamethrin SC and Bayer Activated LN Binder in Pilot Scale Equipment at Anovotek.....	10
Net Drying Trials	10
Machinery Requirements	11
Commercial Application of the Technology.....	13
Start-Up Trials at Siamdutch Mosquito Netting Co., Ltd.....	15
Full Scale Process Validation	16
Example of Production Capacity and Two Year Straight Line Machinery Depreciation Estimates (Largest Capacity System)	16
Example of Production Capacity and Two Year Straight Line Machinery Depreciation Estimates (Smallest Capacity System).....	17
Environmental and Worker Safety.....	17
Technology Advantages.....	19
Technology Transfer.....	19
Further Process Development Efforts.....	20
Summary.....	21

List of Figures

Figure 1. Washex DPM 5000 end-loading washer/extractor.....	2
Figure 2. Washex Challenge CPG 600 industrial dryer.....	2
Figure 3. 50 pound Milnor washer/extractor installed at Anovotek, LLC laboratory	5
Figure 4. Schematic diagram of LLIN chemical application system with valve positions shown for operating a “Mist” application.....	6
Figure 5. Five (5) nets treated with tint over a 5 minute time period and then allowed to tumble for an additional 15 minutes (note the consistency of color between the nets).....	9
Figure 6. LLIN Chemical Feed System engineered, built and integrated into Washex DPM 5000 washer/extractor by Texchine, Inc	14
Figure 7. Example of wet pick-up data from a full scale production trial conducted at Tana Netting (111 100 denier X-Family nets, target WPU = 70%, cycle time = 30 minutes).....	15

List of Tables

Table I. Mist spray application of LLIN chemistry mixture to five (5) X-Family size mosquito nets (5 minutes of solution application plus an additional 15 minutes of tumbling).....	8
Table II. Wet pickup of mosquito nets treated using a mist spray application of tint with the tint being applied over a 20 minute application cycle.....	9
Table III. LLIN Production Process Machinery Options and Manufactures Suggested List Price.....	12
Table IV. Example of AI data from a full scale production trial conducted at Tana Netting (111 100 denier X-Family nets, target AI content = 25 mg/m ² , cycle time = 30 minutes).....	15
Table V. Estimated LLIN production capacity and two year straight line machinery depreciation using 8 and 24 hour per day / 6 day per week / 50 week per year production schedules (largest capacity system).....	16
Table VI. Estimated LLIN production capacity and two year straight line machinery depreciation using 8 and 24 hour per day / 6 day per week / 50 week per year production schedules (smallest capacity system)	17
Table VII. Estimated LLIN production capacity and two year straight line machinery depreciation using 8 and 24 hour per day / 6 day per week / 50 week per year production schedules for the rapid saturation “flood” chemical application method.....	21

Appendices

Appendix A. Efficacy of LNs treated with Deltamethrin SC and Bayer Activated LN Binder on Pilot Scale Equipment at Anovotek Against the Malaria Mosquito (<i>Anopheles Stephensi</i>)	22
Appendix B. Machinery Brochures	25

USAID NetMark LLIN Production Process Executive Summary

This technology is designed to allow companies to convert untreated sewn mosquito nets into Long Lasting Insecticide Treated Mosquito Nets (LLINs). In its simplest form, a factory could be set-up where untreated nets are sourced from a 3rd party supplier, treated with LLIN chemistry in an industrial end-loading open-pocket washer/extractor, dried in an industrial dryer, and then folded and packaged. In reality, it is expected that many companies that implement this technology will also be in the business of manufacturing warp-knit mosquito net fabrics and fabricating sewn nets, in which case those companies will be able to convert nets they had previously sold untreated or bundled with treatment kits into LLINs. In either case, the USAID NetMark LLIN Production Process begins with the input of untreated sewn mosquito nets, thus providing an approach that allows all existing net suppliers to easily forward integrate into LLIN production without having to address the many health, safety and environmental concerns associated with insecticide treatment of yarns and fabric.

The USAID NetMark LLIN Production Process is a batch process, meaning that a finite number of nets (limited by the cylinder size of the washer/extractor) can be processed each production cycle. As a result, if a plant wants to ensure maximum production throughput, it is very important that a significant amount of thought and organization go into pre-production planning. Primarily this would include production scheduling and the preparation of production lots (or batches). With good planning and proper execution, high levels of productivity (exceeding 90% run time) can be achieved.

The USAID NetMark LLIN Production Process is relatively straight forward. A production lot is loaded into an industrial end-loading open-pocket washer/extractor, such as the Washex DPM 5000 apparel processing machine shown in Figure 1, and a predetermined volume of LLIN Chemistry (i.e. ~ 70% wet pick-up) is injected into the machine through a custom engineered mist spray system. The LLIN chemistry is applied to the nets while they rotate and tumble within the machine's cylinder. This results in uniform distribution of LLIN chemistry across all surfaces of the net. The cycle time for LLIN treatment is typically around 30 minutes per production batch.



Figure 1. Washex DPM 5000 end-loading washer/extractor.

After the chemical application process is complete, the treated nets are transported from the washer/extractor to an industrial gas fired or steam heated dryer such as the Washex Challenge CPG 600 shown in Figure 2. Net transportation options range from manual carts and overhead sling systems to fully automated conveyor handling systems.



Figure 2. Washex Challenge CPG 600 industrial dryer.

The production capacity and cycle time of the drying process is essentially the same as for the chemical application process, so one dryer supports the output from one washer/extractor. As a result, the process is very modular, and production capacity needs can be satisfied through the selection of machine size and the quantity of installed machines.

After the drying process, the nets must be transported to a finished goods holding area where they can be inspected, folded, and packaged.

Introduction

Anovotek, LLC was contracted by AED NetMark to work with Siamdutch Mosquito Netting Co., Ltd. and their chemical supplier Bayer Environmental Science to develop a new mechanized process for applying long-lasting insecticide treatment to sewn mosquito nets. NetMark's goal was to take advantage of the development of Bayer's new LLIN treatment product and Siamdutch's research on its own LLIN products to help develop a mechanized treatment process that could be transferred to African net manufacturers.

NetMark's guidelines for Anovotek were to try to develop a process that was: 1) cost-effective; 2) scalable and affordable in terms of using equipment that came in different sizes and prices; 3) robust enough for developing world conditions; 4) based on off-the-shelf equipment whenever possible; and 5) environmentally friendly in terms of maximizing use of the insecticide and minimizing worker exposure.

Given the USAID support for the Anovotek technical assistance and the commitment of Siamdutch and Bayer to the Roll Back Malaria goals, both companies readily agreed that NetMark would have the right to disseminate the technical details of the mechanized process to other companies. NetMark did not fund the purchase of any equipment or chemicals for the Siamdutch factory, so any further refinements of the process by them using their own funds following NetMark participation will not be available for dissemination.

Anovotek's staff has extensive experience in the application of chemicals to textile materials as well as the development and implementation of machinery for processing of textile-related products and materials. They also have extensive contacts throughout textile research organizations, textile universities, machinery suppliers, chemical suppliers, and manufacturers.

Preliminary Research and Target Technology Selection

Early in the process development cycle Anovotek conducted an extensive amount of research into potential application approaches and machinery options. Literature was reviewed and discussions were held with numerous knowledgeable textile processing experts in leading research, machinery, chemical, and manufacturing companies. This work was all done while taking into consideration the exact chemistry being evaluated for the application at Siamdutch plus other similar chemical developments taking place in the industry.

Based on Anovotek's research, understanding of the current process, target requirements of the new mechanized process, and industry experience, it was determined that the approach most likely to succeed and meet the development objectives was to use an industrial washer/extractor for application of the LLIN chemistry (insecticide plus a binder). Other potential technologies that were investigated, but not selected for further development were pad application, mechanized dipping, and continuous spray.

Industrial washers/extractors are simple machines, commonly used worldwide (in both developed and developing countries), extremely reliable, easy to service, have the largest capacity available in a standard machine that can be used for treating nets without modification, and are relatively inexpensive compared to other chemical application machines. In addition, this type of machine is currently being used successfully to apply functional chemicals such as durable press resin, stain repellants and insect repellent to garments and other textile products, so the potential for success in applying LLIN chemistry to mosquito nets was determined to be high.

Feasibility Trials

The first phase of Anovotek's process development research was conducting feasibility trials in a lab-scale washer/extractor owned and operated by a major chemical company. This chemical company has extensive experience in the application of chemicals to garments and other textile materials in garment washing machines. The purpose of the feasibility trials was to determine if garment processing machinery could be used to uniformly apply chemicals onto sewn mosquito nets.

A colored "tint" was used so that it was easy to assess the uniformity of color on the surface of the nets. Early trials indicated that the application of tint, and Bayer's activated LN binder, could be done uniformly in the lab-scale machinery.

Previous studies conducted by the host chemical company indicated that if successful results could be achieved in a lab-scale machine there is an extremely high probability that the process will work equally well or better in a commercial size industrial washer/extractor.

Laboratory Set-Up

Based on the feasibility trial results, Anovotek purchased and installed in its lab a pilot-scale washer/extractor with a custom built chemical mixing, spray and circulation/recovery system for the purpose of conducting extensive process development trials. A photograph of Anovotek's lab-scale washer/extractor is shown in Figure 3.



Figure 3. 50 pound Milnor washer/extractor installed at Anovotek, LLC laboratory.

The pilot-scale washer/extractor and chemical addition system has the following basic specifications:

- Milnor brand washer/extractor
 - ✓ 50 pound rated capacity
 - ✓ Cylinder size 8.18 cubic feet
 - ✓ Wash cycle – 30 seconds clockwise/30 seconds counter clockwise rotation
 - ✓ Variable speed clockwise extraction (low G force extraction)

- Custom built chemical mixing, spray and recirculation system
 - ✓ Variable speed chemical mixing station
 - ✓ 40 liter chemical mixing tank
 - ✓ Wilden P1 – ½” (12.7 mm) air diaphragm pump
 - Flow rated to 56.1 LPM (14.8 GPM)
 - Max pressure 8.6 Bar (125 PSI)
 - ✓ Spray Systems Co. Full Jet chemical application nozzles
 - “Mist” application nozzles
 - 1/8-GD-1 (0.23 GPM @ 60 PSI)
 - 1/8-GD-2 (0.46 GPM @ 60 PSI)
 - 1/8-GD-3.5 (0.81 GPM @ 60 PSI)
 - 1/8-GD-5 (1.20 GPM @ 60 PSI)
 - “Flood” application nozzle
 - ½-GGA-50 (11.6 GPM @ 60 PSI)
 - ✓ Minimum sump volume required for circulation 10 liters

A schematic diagram of the complete chemical application system is shown in Figure 4.

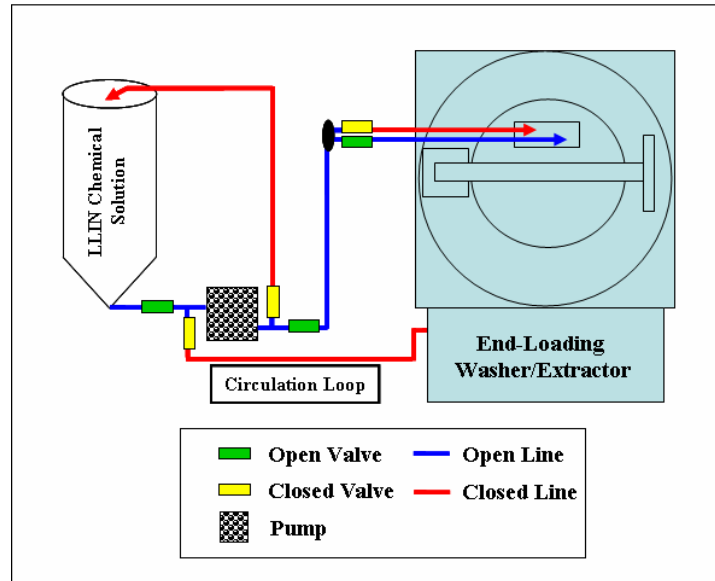

Figure 4. Schematic diagram of LLIN chemical application system with valve positions shown for operating a “Mist” application.

Using this equipment, Anovotek conducted numerous process development trials with strict emphasis being placed on maximizing production throughput. Two basic approaches were evaluated, each having process advantages and disadvantages:

- 1) Low wet pick-up approach utilizing a “mist” type spray application (similar to that employed in the garment finishing industry when applying durable press resin or other functional chemicals).
- 2) Saturation approach utilizing a “flood” type spray application with recirculation and re-use of residual treatment solution.

Low wet pick-up approach

The advantage of this application method is that a precise amount of chemical solution is metered into the process (i.e. enough to result in 60% wet pick-up) and no residual chemical results from the application process.

The disadvantage of the low wet pick-up approach is that it takes time (i.e. 15 minutes) to meter in the chemical solution in a “mist” type spray, and additional processing time (i.e. 10 minutes) is required to allow the sewn nets to tumble within the machine in order for the solution to become uniformly distributed.

In commercial operations where garments are treated in a 1,200 pound capacity machine (loaded at 50% of the rated pounds...i.e. 600 pounds) using a “mist” spray process the average application cycle time is 30 minutes.

Rapid saturation approach

In an effort to decrease the cycle time of the chemical application, Anovotek experimented with a “flood” type spray application where the LLIN chemical mixture is quickly added to the washer/extractor at a volume weighing 3 to 4 times more than the weight of the material being treated. The chemical bath is then circulated through the machine and continuously sprayed onto the tumbling nets. With this approach, sewn nets can be saturated with chemical solution very rapidly (i.e. in less than 5 minutes, with a loading rate of 2 nets per 1.0 ft³ cubic foot of cylinder volume). Following the saturation cycle, an extraction cycle is used to reduce the level of wet pick-up on the nets to approximately 40%.

One advantage of this approach is that the nets can be treated faster, resulting in higher productivity. A second significant advantage is that the loading capacity of nets per treatment cycle can be much greater using the “flood” approach as compared to the “mist” approach. Also, because an extraction cycle is used to reduce chemical wet pickup to approximately 40% (i.e. versus 60-70% WPU for the mist application) drying time and the cost of drying will be lower (on a per net basis). The energy portion of the drying cost is directly proportional to the amount of water that must be evaporated from the nets.

The primary disadvantage of the “flood” approach is that a significant proportion of the treatment chemical (80%) is not consumed by the batch being processed, and it must therefore be captured, reconstituted (spiked with AI and binder), and reused for the next production batch.

After a series of trials using both methods were conducted in the Anovotek laboratory, it was decided to focus only on the “mist” spray approach for the full process and product development effort. This decision was made due to the fact that the mist approach was well proven throughout the garment processing industry, and all preliminary findings suggested that the “mist” spray approach would satisfy each of the project objectives.

Example of Wet Pick-Up and Tint Application Trials using the Mist Spray Approach

Based on observations made during a series of net tumbling experiments, it was determined that five nets (size X-Family, 190 x 180 x 150 cm) per load (1 net per 1.6 ft³ of cylinder volume) was a good starting point for mist spray application trials.

A solution of LLIN chemistry totaling 1278.8 ml (205.1 ml Deltamethrin SC 1% AI, 76.4 ml Bayer activated LN binder, and 991.3 ml of water) was “mist” sprayed onto 5 nets totaling 2121.3 grams (dry weight). Application of the LLIN chemistry was done over a 5 minute time period and then nets were allowed to tumble for an additional 15 minutes. Total cycle time was 20 minutes; target wet pick-up level per net was 60%. As shown in Table I, based on wet pick-up calculations, the application of the LLIN solution was extremely uniform net-to-net with this loading rate and process cycle time.

Table I. Mist spray application of LLIN chemistry mixture to five (5) X-Family size mosquito nets (5 minutes of solution application plus an additional 15 minutes of tumbling)					
Sample Number	Dry Weight (grams)	Wet Weight (grams)	Wet Pick-Up¹ (%)	Calculated AI Content (mg/net)	Calculated AI Content² (mg/SqM of net)
G1	421.4	687.1	63.1	429.2	30.1
G2	422.8	655.0	54.9	375.1	26.3
G3	425.3	661.0	55.4	380.7	26.7
G4	423.3	652.7	54.2	370.6	26.0
G5	428.5	697.1	62.7	433.0	30.4
Standard Deviation			4.4	31.0	2.2
Average			58.1	397.9	27.9
Note ¹ : Target wet pick-up for this trial was 60%.					
Note ² : Target AI content for this trial was 28.66 mg/SqM.					

Tint was also used in a series of trials to provide a means to visually assess the color uniformity on the treated nets. Blue tint was used at a solution concentration of 30 grams tint / liter of water. Five (5) nets were placed in the pilot machine and wet out using a volume of tint solution, which was equivalent to a target wet pick-up of 50% based on the weight of the nets being treated. The tint was sprayed onto the nets using a fine mist type sprayer over approximately 5 minutes, and the nets were allowed to continue to tumble for an additional 15 minutes. This resulted in a total application time of 20 minutes.

After treatment the nets were removed and inspected for color uniformity. The nets were also weighed to determine the level of wet pick-up that was achieved during treatment. As shown in Figure 5, visual inspection indicated that the nets were uniform in color with no white spots being seen on any of the nets.



Figure 5. Five (5) nets treated with tint over a 5 minute time period and then allowed to tumble for an additional 15 minutes (note the consistency of color between the nets).

As shown in Table II, wet pick-up of the nets averaged 49.3%, and the standard deviation of net-to-net wet pick-up was quite low.

Table II. Wet pickup of mosquito nets treated using a mist spray application of tint with the tint being applied over a 20 minute application cycle			
Sample Number	Dry Weight (grams)	Wet Weight (grams)	Wet Pick-Up¹ (%)
X1	425.1	623.4	46.6
X2	424.4	652.1	53.7
X3	428.6	627.8	46.5
X4	427.9	629.0	47.0
X5	427.5	652.9	52.7
Standard Deviation			3.57
Average Wet Pick-Up			49.3
Note ¹ : Target wet pick-up for this trial was 50%.			

Example of Efficacy of Nets Treated with Deltamethrin SC and Bayer Activated LN Binder in Pilot Scale Equipment at Anovotek

Anovotek conducted a series of pilot scale trials similar to those described above using a variety of processing conditions including combinations of:

1. Various chemical mixing procedures
2. Various types of spray nozzles (i.e. patterns, flow rate, droplet size, etc.)
3. Different spray times
4. Various spray pressure
5. Various levels of wet pick
6. Various machine loading rates
7. Etc.

Sample swatches were prepared and sent to Bayer Environmental Science for AI distribution and bio efficacy testing. Specific examples of analytical test data are provided in Appendix A.

Net Drying Trials

Anovotek conducted a series of production-scale drying trials in an attempt to better understand the processing characteristics associated with drying mosquito nets in an industrial dryer. Based on the results of these trials it was determined that if sized correctly (i.e. washer/extractor cylinder volume and dry cylinder volume are comparable in size), one dryer can support the LLIN production volume from one washer/extractor. In practice, the cycle time of the dryer will normally be 10-12 minutes shorter than the cycle time of the chemical application process, but since it is very important not to let “wet” treated nets sit for extended periods of time (due to the fact that gravitational forces will cause migration of the chemistry) a 1:1 washer to dryer ratio is required.

Note that care must be exercised when selecting and using an industrial garment dryer for drying of LLIN treated mosquito nets. Both the warp knit polyester construction of the fabric and the chemical structure of the insecticide are very sensitive to damage if overheated. Modern dryers with modulating burner controls are necessary. Operating temperatures must be established based on the insecticide, loading rate and mechanical design of the dryer being used. Care must also be taken to slowly cool down the nets to avoid creases and wrinkles in the nets after drying.

Note that all of Anovotek’s drying trials were conducted using high set point temperatures between 60° and 70° C, which is well below Bayer’s recommended maximum temperature of 90° C for drying products treated with Deltamethrin SC.

Machinery Requirements

The following three pieces of industrial scale processing equipment are necessary to establish a manufacturing cell for LLIN production:

1. End-loading open-pocket garment washer/extractor
2. End-loading open-pocket garment dryer with auxiliary wet type lint collector
3. Custom engineered chemical feed system

This type of garment processing equipment is readily available worldwide from companies such as Washex, GA Braun, Pellerin Milnor, and others. The chemical feed system must be custom engineered, built and integrated separately.

Industrial grade washer/extractors and dryers are available in a wide range of sizes, with the smallest scale equipment having cylinder sizes in the 8 to 12 ft³ range, and the largest machines in the industry offering up to 178 ft³ of cylinder volume. Table III shows a range of machinery options and the manufactures suggested list price for each.

**Table III. LLIN Production Process Machinery Options
and Manufactures Suggested List Price**

Washer/Extractor			Dryer			Chemical Feed		Estimated Capacity ³ (nets/hr)
Make and Model ¹	Cylinder Volume (ft ³)	List Price ² (\$)	Make and Model ¹	Cylinder Volume (ft ³)	List Price ² (\$)	Make and Model ¹	List Price ² (\$)	
Washex RVS550	21	\$22,610	Washex FL623G	35	\$27,980 ⁴	Texchine TX21	\$18,200 ⁵	24
Washex FLPS-1200	42	\$83,140	Washex FL633G	49	\$35,630 ⁴	Texchine TX42	\$18,200 ⁵	47
Washex FLPS-2250	80	\$124,370	Washex CPG200	100	\$75,040 ⁴	Texchine TX80	\$18,200 ⁵	90
Washex DPM4000	141	\$143,550	Washex CPG400	155	\$94,030 ⁴	Texchine TX141	\$18,200 ⁵	159
Washex DPM5000	178	\$152,100	Washex CPG600	210	\$105,100 ⁴	Texchine TX178	\$18,200 ⁵	200
GA Braun 145ST	144	TBD	GA Braun 440P-NG	165	\$84,215 ⁶	TBD	TBD	162
Milnor 64046-J6N ⁷	86	\$158,105	Milnor SL-65058	108	\$67,515 ⁶	TBD	TBD	97
Milnor 72058-J2N ⁸	137	\$134,945	Milnor SL-72072	170	\$81,530 ⁶	TBD	TBD	154
Milnor 72075-J2N ⁸	178	\$144,340	Milnor SL-M670	256	\$85,615 ⁶	TBD	TBD	200
Milnor 72058-J5N ⁷	137	\$190,895	Milnor SL-M460	175	\$83,425 ⁶	TBD	TBD	154

Note¹: See Appendix B for an assortment of machinery brochures.

Note²: Machinery list prices are for base model equipment. Numerous options are available, some of which may be required for operation in locations outside the U.S. Other costs that must also be taken into consideration when planning for this type of investment include: 1) Freight, 2) Installation and 3) Start-up by Factory Certified Technicians. Note that the cost of these services will vary by carrier, machinery vendor, size and quantity of production modules purchased and location of installation. Please consult the machinery manufacturer for firm quotations.

Note³: Estimated capacity based on lot sizes equal to one (1) X-Family net (190 x 180 x 150 cm) per 1.6 ft³ of washer/extractor cylinder volume, 30 minute total cycle time, and 90% production efficiency.

Note⁴: Price includes auxiliary wet type lint collector.

Note⁵: This price is for the “Mist” spray system.

Note⁶: Price does NOT include auxiliary wet type lint collector.

Note⁷: Denim processing machine similar in design and features to a Washex DPM machine.

Note⁸: Apparel processing machine similar in design and features to a Washex DTF machine.

As shown in Table III, cylinder volume is an important metric, because this machine parameter limits the production capacity of the washer/extractor for treating mosquito nets with LLIN chemistry. Anovotek’s research and development efforts have determined that a ratio of 1 net (X-Family, 190 x 180 x 150 cm) per 1.6 ft³ of cylinder volume yields excellent LLIN treatment results (when using a 30 minute production cycle). This means that a small machine with an 8.0 ft³ cylinder can only process 5 nets (X-Family, 190 x 180 x 150 cm) per production cycle, while the largest machines with 178 ft³ cylinders can process 111 nets (X-Family, 190 x 180 x 150 cm) per production cycle. Attempting to over fill the machine with too many nets in one production batch will result in poor distribution of LLIN chemistry because the nets will not tumble and move properly within the cylinder.

Commercial Application of the Technology

The first commercial installation of this technology, completed by Siamdutch Mosquito Netting Co., Ltd utilizes the following Washex brand garment processing equipment and chemical feed system purchased from Texchine, Inc. (Texchine, Inc. is Washex's largest distributor worldwide, with offices located in Chapin, South Carolina and Atlanta, Georgia). Texchine, Inc. has extensive experience with the development and installation of new applications using industrial laundry equipment. Texchine also has the in-house engineering capability and experience to design, build and integrate the required chemical handling system (contact Mel Harrill at +1 800 768 8205 ext. 107, or via e-mail at melharrill@texchine.com). Standard machinery specifications include:

- Washex model DPM 5000 End-Loading Open-Pocket Washer/Extractor
 - ✓ Hydraulic -Two way tilt (20 degree load/27 degree unload), 79" x 63" open pocket 5000 liter (178.7 cubic foot) cylinder
 - ✓ Elite microprocessor control
 - ✓ Single motor drive
 - ✓ Dry Zone Bearing (DZB) design
 - ✓ Quick Seal Replacement (QSR) design
 - ✓ Removable cylinder inserts
 - ✓ Programmable variable cylinder speeds
 - ✓ Rigid mount construction
 - ✓ Four (4) straight breakers
 - ✓ Liquid supply inlets, (12)
 - ✓ Anti-siphon air gap
 - ✓ Drain and air trap flush
 - ✓ Gentle action for delicate textiles
 - ✓ Down drain
 - ✓ Flow meter
 - ✓ Manual supply canister - 10 Gal.
 - ✓ 380 Volt/ 50 Hz. / 3 Phase (transformer supplied for other voltages)
 - ✓ Automatic door
 - ✓ 12 liquid supply signals and 1 reuse drain signal (no reuse drain valve)
 - ✓ pH titration valve
 - ✓ 2" nipple on drain box
 - ✓ Automatic cylinder venting system

- Washex Challenge model CPG 600 Pacesetter Tumbler Dryer
 - ✓ 675 pound (305 kg) dry weight capacity gas fired dryer with a production rating of *19 pounds of water removed per minute, with built-in energy saver device capable of *1800 BTU's per pound of water removed
*(Based upon a full load of 100% terry material @ 60-65% moisture retention, fully dried)
 - ✓ Geyseric burner with high/low gas train
 - ✓ Patented axial airflow system
 - ✓ 210 cubic foot basket driven by polyurethane rollers

- ✓ Teflon basket seals
 - ✓ No basket wiper seals required
 - ✓ Four point basket suspension
 - ✓ Patented direct drive swing-out exhaust blower (6,500 CFM) with 20 HP motor
 - ✓ 55.5" door opening
 - ✓ Automatic fire protection system
 - ✓ Air operated door(s) with Pyrex glass observation window
 - ✓ Hand jogging switch
 - ✓ Manual timers
 - ✓ Manual exhaust temperature control
 - ✓ Wet lint collector Model SM-9 (9,000 CFM water wash)
- Custom built chemical feed system (see Figure 6 below)
 - ✓ Unit is skid mounted and installed next to DPM 5000
 - ✓ Unit is controlled by microprocessor on DPM 5000 to allow for automated batch processing
 - ✓ Unit includes all necessary tanks, pumps, piping, valves and utility hook-ups for mist spray application of LLIN chemicals
 - ✓ Option 1 – System can be built to allow for flood, recirculation, and reuse processing
 - ✓ Option 2 – System can incorporate automated chemical metering and mixing station



Figure 6. LLIN Chemical Feed System engineered, built and integrated into Washex DPM 5000 washer/extractor by Texchine, Inc.

Full Scale Process Validation

Siamdutch Mosquito Netting Co., Ltd is currently in the process of completing full scale process validation trials. Publicly available data are currently pending completion of further process optimization trials and complete analytical testing.

Example of Production Capacity and Two Year Straight Line Machinery Depreciation Estimates (Largest Capacity System)

For purposes of making production capacity calculations, it is recommended that the following parameters be taken into consideration:

- a. Machine loading capacity
 - i. One (1) size X-Family net (190 x 180 x 150 cm) per 1.6 ft³/cylinder volume
- b. Treatment time (25 minutes per production batch)
- c. Loading and unloading the machine (5 minutes per production batch)
- d. Production efficiency 90%

Based on these processing parameters and the estimated required investment for the largest capacity Washex/Texchine machinery (as detailed above in Table III) production capacity and two year straight line machinery depreciation estimates (\$ per net) were calculated. This data is shown in Table IV, for both 8 and 24 hour per day manufacturing operations.

Table IV. Estimated LLIN production capacity and two year straight line machinery depreciation using 8 and 24 hour per day / 6 day per week / 50 week per year production schedules (largest capacity system)¹								
Application Process	DPM 5000 Volume (cubic/ft)	# of Nets Processed per Cycle	Target Total Cycle Time (min)	Target Production Efficiency (%)	Max Net Production Per Day	Max Net Production Per Week (6 days/wk)	Max Net Production Per Year (50 wks/yr, 6 days/wk)	Cost Per Net Using a 2 Year Payback Period²
8 Hrs/Day	178	111	30	0.90	1,598	9,588	479,400	\$0.312
24 Hrs/Day	178	111	30	0.90	4,794	28,764	1,438,200	\$0.104
Note ¹ : Note that Table IV only includes the per net, two year machinery straight line depreciation cost of producing LLIN products. The cost of chemicals is NOT included. Note ² : Based on total estimated machinery cost of \$299,146 USD for the Washex/Texchine DPM5000/CPG600 turnkey system (including estimated freight, installation, and start-up).								

Example of Production Capacity and Two Year Straight Line Machinery Depreciation Estimates (Smallest Capacity System)

Based on the processing parameters detailed above and the estimated required investment for the smallest capacity Washex/TeXchine machinery (as detailed above in Table III) production capacity and two year straight line machinery depreciation estimates (\$ per net) were calculated. This data is shown in Table V, for both 8 and 24 hour per day manufacturing operations.

Table V. Estimated LLIN production capacity and two year straight line machinery depreciation using 8 and 24 hour per day / 6 day per week / 50 week per year production schedules (smallest capacity system)¹								
Application Process	DPM 5000 Volume (cubic/ft)	# of Nets Processed per Cycle	Target Total Cycle Time (min)	Target Production Efficiency (%)	Max Net Production Per Day	Max Net Production Per Week (6 days/wk)	Max Net Production Per Year (50 wks/yr, 6 days/wk)	Cost Per Net Using a 2 Year Payback Period²
8 Hrs/Day	21	13	30	0.90	187	1,122	56,100	\$0.791
24 Hrs/Day	21	13	30	0.90	561	3,366	168,300	\$0.264
Note ¹ : Note that Table V only includes the per net, two year machinery straight line depreciation cost of producing LLIN products. The cost of chemicals is NOT included. Note ² : Based on total estimated machinery cost of \$88,790 USD for the Washex/TeXchine RVS550/FL623G turnkey system (including estimated freight, installation, and start-up).								

When comparing Tables IV and V above, note the economies of scale associated with operating higher capacity equipment. Also note the significant effect that machinery run time (8 versus 24 hour per day manufacturing operations) has on allocated machinery depreciation cost per net.

Technology Advantages

There are a number of advantages associated with adopting this LLIN treatment technology when compared to other LLIN production options. These include:

- The process was developed around readily available, off-the-shelf, industrial grade equipment that only requires a special adaptation for the insecticide treatment chemical feed system.
- The equipment can be scaled to match the desired LLIN output capacity because it is available in a range of sizes (i.e. from 8 ft³ to 179 ft³ of cylinder capacity). Note that there are definitely economies of scale as larger capacity production modules (i.e. twice the capacity of a smaller system) don't cost twice as much.
- The process is designed to have zero effluent and low environmental impact.

- Chemical treatment is done at the end of the net production process, in a closed vessel, resulting in minimal worker exposure to insecticide and/or insecticide treated fabric.
- The technology is easily installed at the end of the net production process and provides rapid and high quality mass treatment of finished nets.
- The technology can potentially be used with numerous brands of insecticide treatment (i.e. Bayer, Syngenta, BASF, generic, etc.).
- Specifications for implementing the technology are available to all companies because of the NetMark-Siamdutch agreement to encourage technology transfer.
- Relatively low barrier to entry – low investment capital required as compared to other LLIN technology options (i.e. extrusion of LLIN treated yarn, application of LLIN chemistry at pad and stenter frame).

Technology Transfer

In general, transferring this technology to other mosquito net manufactures should be relatively straight forward. This is based on the fact that Bayer Environmental Science now has a commercially available LLIN chemical package (and others such as Syngenta and BASF are believed to be developing competitive products), and a turnkey equipment solution incorporating Washex's industrial apparel processing equipment is available through Texchine, Inc.

Anovotek recommends the following path forward for companies interested in adopting this technology:

1. Contact the USAID NetMark Program and express interest in learning more about their mechanized LLIN treatment process and technology transfer initiative. Inquires can be addressed to either:

David McGuire
 Vice President and Director
 Center for Private Sector Health Initiatives
 Academy for Educational Development
 1875 Connecticut Ave., NW
 Washington, DC 20009-5721
dmcguire@aed.org
 (202) 884-8506

or

Dr. Will Shaw
 Vice President
 Health, Population and Nutrition Group
 Academy for Educational Development
 1875 Connecticut Ave., NW
 Washington, DC 20009-5721
wshaw@aed.org
 (202) 884-8864

2. Select LLIN chemistry provider (i.e. Bayer, Syngenta, BASF, or other)
3. Run proof of concept lab scale trials (i.e. via Anovotek, LLC or other)
4. Select treatment technology provider (i.e. Washex/Texchine Inc., GA Braun, Pellerin Milnor, or other)
5. Identify potential sources of matching investment from international organizations desiring to support LLIN technology transfer.

Further Process Development Efforts

Although not fully pursued during Anovotek’s most recent LLIN process development efforts it is anticipated that further research and development will be sponsored by USAID NetMark to fully understand the dynamics of using the rapid saturation “flooding” approach for LLIN treatment. As previously mentioned, the advantage of this treatment technology would be substantially higher machine loading rates (i.e. 2.5X), slightly faster cycle times, and correspondingly lower capital equipment costs (on a per net basis). If successful, production rates and two year straight line machinery depreciation costs are estimated to be similar to that shown in Table VI.

Table VI. Estimated LLIN production capacity and two year straight line machinery depreciation using 8 and 24 hour per day / 6 day per week / 50 week per year production schedules for the rapid saturation “flood” chemical application method¹								
Application Process	DPM 5000 Volume (cubic/ft)	# of Nets Processed per Cycle	Target Total Cycle Time (Min)	Target Production Efficiency (%)	Max Net Production Per Day	Max Net Production Per Week (6 days/wk)	Max Net Production Per Year (50 wks/yr, 6 days/wk)	Cost per Net Using a 2 Year Payback Period²
8 Hrs/Day	178	278	20	0.9	6,005	36,029	1,801,450	\$0.122
24 Hrs/Day	178	278	20	0.9	18,015	108,087	5,404,350	\$0.041
<p>Note ¹: Note that Table VI only includes the per net, two year machinery straight line depreciation cost of producing LLIN products. The cost of chemicals is not included.</p> <p>Note ²: Based on total estimated machinery cost of \$440,000 USD for the Washex/Texchine DPM5000/CPG600 turnkey system (including estimated freight, installation, and start-up). Additional machinery costs for “flooding” versus “mist” spray include flood, recirculation and re-use option on the Chemical Feed system, and an additional dryer (a 1:2 washer-to-dryer ratio will be required).</p>								

Summary

The USAID NetMark LLIN Production Process was developed through partnership between USAID's AED NetMark Program, Siamdutch Mosquito Netting Co., Ltd., Bayer Environmental Science, and Anovotek, LLC.

Numerous possible approaches to produce LLIN products were discussed and investigated. Based on this work, the partnerships collective understanding of the current process (hand dipping), target requirements for the new mechanized process, and industry experience, it was determined that the approach most likely to succeed and meet the development objectives was to use industrial apparel processing equipment for application and drying of the LLIN chemistry (insecticide plus a binder).

Anovotek built a pilot scale system and conducted numerous trials in order to fully understand the machinery specifications and processing parameters that result in uniform application of LLIN chemistry. Based on pilot scale data and recommendations from Anovotek, LLC, Siamdutch invested a significant amount of capital in a new plant and equipment specifically designed around this LLIN treatment technology.

Currently, the plant is conducting process optimization trials in order to maximize product quality, process reliability and production throughput. Application for WHOPES certification is in process and fully anticipated.

Companies interested in learning more about this technology and how it can be effectively implemented into their manufacturing facilities should contact USAID's AED NetMark program.