

Mid Project Report
Volume VI

Appendix E - Training
How To Do It Series

Prepared under support of
United States Agency for International Development
Contract AID/NE-C-1351

All reported opinions, conclusions or
recommendations are those of the writers
and not those of the funding
agency of the United States Government

By

Egyptian and American Team Members



Egypt Water Use and Management Project

Engineering Research Center
Colorado State University
Fort Collins, Colorado 80523 USA

or 22 El Galaa Street
Bulak, Cairo, ARE

September 1980

TABLE OF CONTENTS

	<u>Page</u>
GROUNDWATER MONITORING TECHNIQUES	2
PROCEDURE FOR OBSERVATION WELL INSTALLATION	4
MEASUREMENT OF HYDRAULIC CONDUCTIVITY	7
INTRODUCTION	7
SPECIAL APPARATUS	10
PROCEDURE	11
CALCULATIONS	11
COMMENTS	12
SOIL CLASSIFICATION	15
INTRODUCTION	15
SOIL TEXTURE	15
SOIL PARTICLE SIZE ANALYSIS BY THE HYDROMETER METHOD	18
PARTICLE SIZE ANALYSIS BY SIEVING	25
CROP SURVEY METHODS	28
MAPPING CROP STANDS	31
YIELD ESTIMATE METHODS	34
CONSUMPTIVE USE	36
INTRODUCTION	36
COMPUTING EVAPOTRANSPIRATION	36
MEASUREMENT OF EVAPOTRANSPIRATION	41
DIFFERENTIAL LEVELING FOR BENCH MARK SURVEY OF THE WATERCOURSE	50
THEORY OF LEVELING	50
PROCEDURE FOR DIFFERENTIAL LEVELING	52
CLOSED SURVEYS	55
ERROR OF CLOSURE	58
CHECKING THE LEVEL NOTES	58
USE OF THE BENCH MARK SURVEY	58
PORTABLE TURNING POINTS	59
PROFILE LEVELING OF MAIN AND LATERAL CONVEYANCE CHANNELS	60
VEGETATIVE LAND USE MAPPING	67
SOIL MOISTURE DETERMINATION TECHNIQUES	73
SOIL MOISTURE SAMPLING AND CALCULATION USING A KING TUBE SAMPLER	78

	<u>Page</u>
SOIL PROFILES AND WATER TABLES	82
GUIDELINES FOR CUTTHROAT FLUME INSPECTION	84
TABLE OF LINEAR DIMENSIONS	85
TABLE OF ANGLES MEASURED	85
GENERAL QUALITATIVE MEASURES AND OBSERVATIONS	85
HOW TO READ STAFF GAUGE ON FLUME AND HOW TO DETERMINE DISCHARGE FROM THE READING	87
STAFF GAUGE	87
HOW TO READ THE GAUGE	87
DETERMINING THE DISCHARGE	89
PRECAUTIONS FOR USE OF STAFF GAUGE	89
COLLECTING SOIL SAMPLES FOR SOIL FERTILITY AND SALINITY ANALYSES	91
INSTALLATION AND USE OF CUTTHROAT FLUMES FOR WATER MEASUREMENT	94
THEORETICAL CONSIDERATION	94
INSTALLATION AND OPERATIONAL CONSIDERATIONS	97
INTERPRETATIONAL CONSIDERATIONS	99
FIELD AND WATERCOURSE ORIENTATION MAPPING USING PLANE TABLE AND PEEP-SIGHT ALIDADE	105
THE PLANE TABLE	105
THE ALIDADE	107
SETTING UP THE PLANE TABLE	107
ORIENTING THE PLANE TABLE	107
TOPOGRAPHIC MAPPING USING GRID METHOD AND LEVEL	113
METHODS OF MAPPING	114
THE GRID METHOD	114
PROCEDURE FOR THE GRID METHOD OF MAPPING	115
MAP PREPARATION	116
EVALUATION OF FURROW IRRIGATION SYSTEMS	120
INTRODUCTION	120
REQUIRED DATA	120
DISCUSSION AND RECOMMENDATIONS	128
FIELD DATA ANALYSIS	129
EXAMPLE SYSTEM EVALUATION	136
CONCLUSIONS	145
RECOMMENDATIONS	146
COLLECTION AND ANALYSIS OF MORE DETAILED DATA	146
EQUIPMENT LIST AND SUGGESTED DATA FORMS	150
APPENDIX A--RECONNAISSANCE QUESTIONNAIRE	159
BIBLIOGRAPHY	162

	<u>Page</u>
EVALUATION OF GRADED BORDER IRRIGATION SYSTEMS	163
INTRODUCTION	163
REQUIRED DATA	163
DISCUSSION AND RECOMMENDATIONS	168
FIELD DATA ANALYSIS	170
EXAMPLE SYSTEM EVALUATION	180
CONCLUSIONS	189
RECOMMENDATIONS	190
EQUIPMENT LIST AND SUGGESTED DATA FORMS	191
APPENDIX A--RECONNAISSANCE QUESTIONNAIRE	199
APPENDIX B--SOIL MOISTURE MEASUREMENT CONSIDERATIONS	202
BIBLIOGRAPHY	204
 GUIDELINES FOR IRRIGATION EVALUATIONS	 205
 IRRIGATION EVALUATION PROCEDURE FOR FLOODED RICE CROPS	 209
INTRODUCTION	209
METHODOLOGY	210
PROCEDURE	212
EQUIPMENT	214
DATA RECORD	214
 ESTIMATION OF WATER LOSSES WHICH OCCUR IN DELIVERY SYSTEMS BEFORE THE WATER REACHES THE FIELD	 216
 SUBMISSION DELIVERY EFFICIENCY (E_s)	 219
 METHODS OF MEASURING SEEPAGE RATES	 222
 MEASURING TUBEWELL DELIVERY	 227
 FIELD DATA COLLECTION	 230
INTRODUCTION	230
DEVELOPMENT OF THE SURVEY QUESTIONNAIRE	231
DEFINITION	231
DESIGNING THE QUESTIONNAIRE	231
WHO USES THE QUESTIONNAIRE	232
THE QUESTIONNAIRE	232
SURVEY PRETEST	237
 FIELD DIARIES	 240
OBJECTIVES FOR THE FIELD DIARY	240
PROCEDURE FOR WRITING A FIELD DIARY	243
CONTENT OF THE FIELD DAY	243
REFERENCES	245
 FIELD INTERVIEW TECHNIQUES	 246
OBJECTIVE	246
RESPONSIBILITY	246
GUIDELINES	246

	<u>Page</u>
SAMPLING	250
ASPECTS OF SAMPLING PROCEDURE	250
EXAMPLE	256
VALIDITY AND RELIABILITY CHECKS: INTERVIEW DATA	259
LINEAR PROGRAMMING TEACHING MANUAL	266
INTRODUCTION	266
INTERPRETING THE RESULT	271
SENSITIVITY ANALYSIS	273
EXPANDED MODEL	279
DISCOUNTING	286
PARTIAL BUDGETS	295
FARM ENTERPRISE BUDGETING	300
PREPARING A CASH FLOW BUDGET	306
CASH FARM RECEIPTS	307
CASH FARM EXPENSES	307
THE PRODUCTION FUNCTION AND FARM PROFIT MAXIMIZATION	311
SOIL-WATER ENGINEERING LABORATORY MANUAL	311
APPENDIX	400

HOW-TO-DO-IT SERIES

Preface

Volume I of the Problem Identification Training Manual consists of a number of short, technical "How-To-Do-It" articles. The purpose of these articles is to provide specific instructions on how to carry out the tasks of problem identification. The How-To-Do-It series is merely a supplement to the problem identification process (Volume I) and therefore the skills presented here are some of the tools necessary to complete a problem identification study.

The format of this volume will be organized along the following major categories:

- 1) How-To-Do Methodologies related to the farmer's field;
- 2) How-To-Do Methodologies related to the irrigation water;
- 3) How-To-Do Methodologies related to the farmer's socio economic network.

This methodology series is meant to provide all trainees with methods of how to perform specific field tasks in problem identification. The actual execution of these methods, however, requires training for discipline members of field teams. The particular methods to be used depends on the actual field situation and type of problems being investigated. Each team member should keep in mind that this volume contains methods which will help team members in problem identification.

Additional How-To-Do Methodologies will be provided to the trainees during the Training Program.

EWUP

How to do it

Field Procedure



GROUNDWATER MONITORING TECHNIQUES

by Dan Sunada

INTRODUCTION

The most common method for obtaining groundwater levels are through the use of observation wells and piezometers. The observation wells are cased with either steel or plastic perforated pipe.

Usually the observation wells are installed on a grid system and usually in clusters at each location when the aquifer is stratified. The clusters of wells are installed at differing depths so that information on the individual stratum can be identified. When detailed information on water levels are needed (i.e. near canals and drains), a line of well may be installed to better define the hydraulic gradient. Detailed driller's logs should be obtained in order to identify the types and composition of the individual strata, their thickness, and the thickness of the total aquifer. Information from the driller's log will also provide information for the depths of the wells. Shallow wells (less than 5 meters) can also be installed by project personnel when the well casing can be driven using a well point of a small drilling rig. Of course, driller's log information may not be obtainable from this type of installation.

After the observation wells have been installed, much data can be collected on the hydraulic conductivity, specific yield, and storage coefficients, transmissibility, and other values. The water should be sampled for laboratory analysis once for reference and periodical field measurement of electrical conductivity should be made. The water table elevations should be periodically measured and recorded for each well with some wells measured continuously by recorders. Each well should be provided with a cap to keep debris and small children playing in the area from destroying the usefulness of the wells. In addition, the wells should be periodically flushed to insure representative flows and water quality information.

Piezometers are small diameter pipes perforated only at the descend depth. Piezometers are used to obtain a measure of the hydraulic potential

of the aquifer at the depth corresponding to the perforation of the piezometer. Piezometers may also be used to collect water quality samples for laboratory analysis.

Piezometers are also installed on a grid systems (usually fairly close to the wells) and in a cluster arrangement. Under good conditions with few large rocks, piezometers can often be installed by project personnel by use of a jetting rig by which water is forced through the piezometer pipe as it is lowered into the ground (Mickelson et al., 1961); (Donnan and Bradshaw, 1952). The force of the water jet removes the unconsolidated particles. Piezometers are also often driven into place. Information on the installation and evaluation of piezometers is presented by the USDI-USBR (1964), Reeve and Jensen (1949), Bornstien and Alberts (1963), Myers and Van Bavel (1962), and Donnan and Bradshaw (1952).

When selecting the sites for observation wells and piezometer installations, they should be located where vehicular traffic, farming equipment, or road maintenance equipment will not disturb or remove the upper portions of the pipes.

The water level measurements for piezometers and wells are usually measured from the top of the pipe to the water level. Therefore, in order to relate all the data from all of the wells and piezometers in a grid system, it is necessary to determine the elevations of the tops of each well and piezometer casing, and thereby the respective water level elevations for each well and piezometer.

Equipment for water sampling and depth to water determinations are commercially available. However, it often becomes necessary to construct equipment to meet the specific requirements of the project installations.

EWUP

How to do it

Field Procedure



PROCEDURE FOR OBSERVATION WELL INSTALLATION

by Alan Early and Nasir Ahmed*

When plans are being formulated to provide the irrigation water during the growing season, a knowledge of the amount of water which might be available from the soil itself is valuable information. The possibilities that the water table rises so high as to reduce crop production should also be evaluated. Both the depth of the water table and its fluctuations during the growing season are important.

Instructions for the field engineer are outlined below which will aid in the installation of observation wells. These, in turn, provide the means for measuring water table levels and fluctuations, as necessary, beneath a watercourse system.

Procedure for Installation

1. Survey the hand pumps, open wells, ponds, etc. throughout the area involved. Note the depth to the water table of each, on the attached form. If the depth exceeds 20 feet, contributions from the water table to plant needs will be negligible.
2. Consult well drillers, water users, hydrologists, etc., acquainted with the area and get their opinions as to the normal annual fluctuation of the water table from the current levels. Design the observation wells tube at 2 feet (60 cm) deeper than the lowest water table level expected. The observation wells should, when possible, be placed at field intersections.
3. Auger the hole. (A screw type auger may be used for clay or silt soils. A bucket type auger is satisfactory for all soil textures.) Bore to a level at least two feet (60 cm) lower than

*This article was taken from The Problem Identification Handbook (April 1, 1980). Developed by the CSU-Pakistan Water Management Project sponsored by U.S. Agency for International Development Contract No. AID/TAC-1100.

the expected lowest level of the water table. The diameter of the augered hold should match the outside diameter of the pipe.* Available augers larger than the pipe may be used, but the pipe will not be as firmly anchored and secured from theft.

4. If available, pour coarse sand or pea gravel into the hole in quantity sufficient to fill the bottom 6" (15 cm).
5. Excavate a collar-shaped area, 1 foot (30 cm) in diameter, around the pipe. Fill this excavation with concrete to the level of the surface of the surrounding soil. The primary purpose of this concrete collar is to reduce the possibility of theft, and it may be eliminated if the area is secure.

*The top of the pipe should be about 4" (10 cm) above the surface of the ground and should be threaded to accept a cap which can be screwed on with pipe wrenches. When the well is not attended, the cap should always be screwed on with sufficient force that it cannot be opened manually by irresponsible persons who might drop soil and debris into the well.

SUGGESTED TABULATION FORM

WATERCOURSE

Date	Type of Observation	Depth of WT	Location	HMT
------	---------------------	-------------	----------	-----

EWUP

How to do it

Field Procedure



MEASUREMENT OF HYDRAULIC CONDUCTIVITY

by The Auger Hole Method

adapted by I. Garcia

Object: To measure saturated hydraulic conductivity in the field using the auger-hole method.

INTRODUCTION

Hydraulic conductivity is defined as a measure of the ease with which water can be transmitted through a porous material. The hydraulic conductivity is also defined as the physical property which can be measured and expressed as a proportionality factor (K) in the Darcy equation,

$$q = -K \frac{\Delta H}{\Delta L} \quad (1)$$

where q is the volume flux ($L t^{-1}$) and $\Delta H/\Delta L$ which is the hydraulic gradient ($L L^{-1}$). In this equation, the hydraulic conductivity K ($L T^{-1}$) depends both on the nature of the porous medium (soil) and the physical properties of the fluid (water).

Measurements of saturated hydraulic conductivity are used in the analysis of any saturated soil water-flow system. These include drainage of soils for agricultural; drainage of highways, airports, and construction sites; and the determination of seepage below dams.

PRINCIPLES

The auger hole method of measuring the hydraulic conductivity of soil is illustrated in Figure 1. (1) A cylindrical hole is augered into a body of soil that is water saturated. (2) Water is allowed to seep into and fill the auger hole to the level of the water table. (3) The depth H of the hole below the water table is measured. (4) Some or all of the water in the auger hole is quickly removed to a distance y below the water table. Finally, (5) The rate of rise of water in the auger hole, which is related to the hydraulic conductivity of the soil, is measured.

In Figure 1, r is the radius of the auger hole and S is the distance from the bottom of the auger hole to the impermeable barrier.

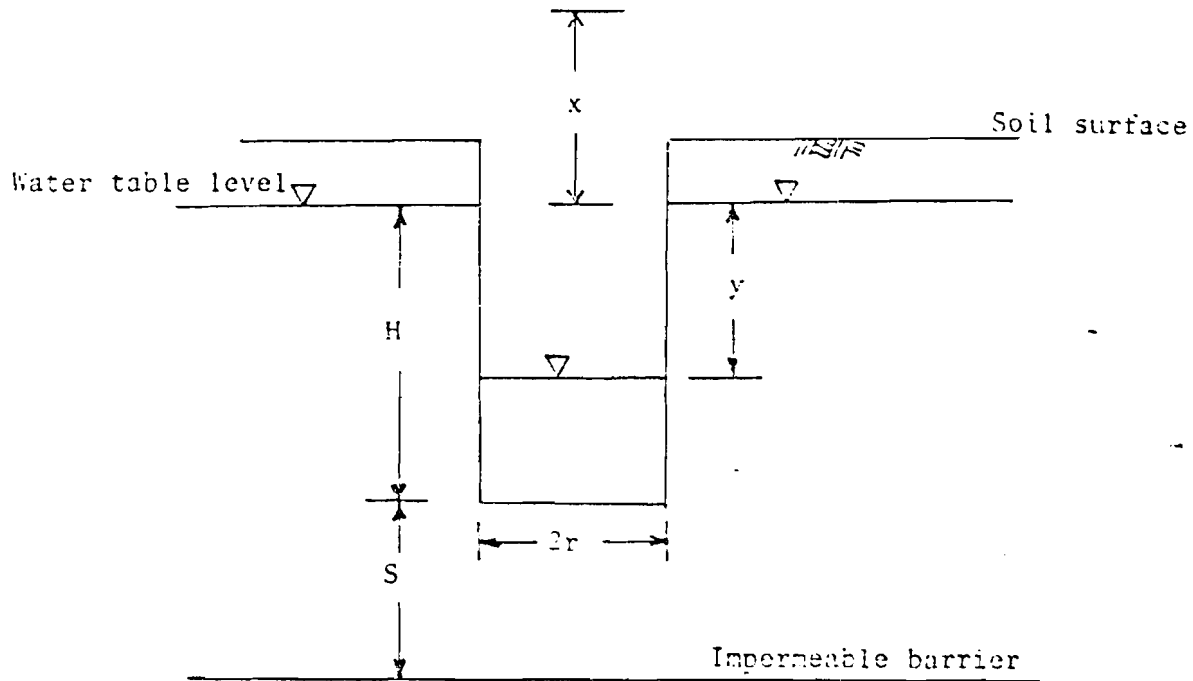

Figure 1. The auger hole method.

The relationship between the observed rate of rise of water in the auger hole and the hydraulic conductivity is expressed by

$$K = - C \frac{dy}{dt} , \quad (2)$$

where C is the shape factor (see below) of the auger hole, dy is the change in water height in the auger hole (cm) that occurs in time dt (sec) and K is the hydraulic conductivity (m day^{-1}). The mixed units m/day , cm and sec , in Equation 2 are used for practical work. If homogeneous units are used, then Equation 2 becomes

$$K = - \frac{C}{864} \frac{dy}{dt} , \quad (3)$$

where K and dy/dt have the same units and $C/864$ is dimensionless.

The values of C in Table 1 were obtained using auger hole seepage theory (Boast and Kirkham, 1971). The values of C are for a wide range of auger hole geometries. The shape of the auger hole is characterized by the ratio of the length of the auger hole below the water table H to the radius of the auger hole r . Table 1 contains C values for auger holes of seven values of H/r ranging from $H/r = 1$ to $H/r = 100$ (a quite small diameter auger hole). For each of the seven values of H/r , C is shown for

Table 1. Values of C for Equation 2 for auger holes underlain by impermeable or infinitely permeable material (Boast and Kirkham, 1971).

H/r	y/H	S/H								S/H ∞
		0	0.05	0.1	0.2	0.5	1	2	5	
1	1	447	423	404	375	323	286	264	255	254
	0.75	469	450	434	408	360	324	303	292	291
	0.5	555	537	522	497	449	411	386	380	379
2	1	186	176	167	154	134	123	118	116	115
	0.75	196	187	180	168	149	138	133	131	131
	0.5	234	225	218	207	188	175	169	167	167
5	1	51.9	48.6	46.2	42.8	38.7	36.9	36.1		35.8
	0.75	54.8	52.0	49.9	46.8	42.8	41.0	40.2		40.0
	0.5	66.1	63.4	61.3	58.1	53.9	51.9	51.0		50.7
10	1	18.1	16.9	16.1	15.1	14.1	13.6	13.4		13.4
	0.75	19.1	18.1	17.4	16.5	15.5	15.0	14.8		14.8
	0.5	23.3	22.3	21.5	20.6	19.5	19.0	18.8		18.7
20	1	5.91	5.53	5.30	5.06	4.81	4.70	4.66		4.64
	0.75	6.27	5.94	5.73	5.50	5.25	5.15	5.10		5.08
	0.5	7.67	7.34	7.12	6.88	6.60	6.48	6.43		6.41
50	1	1.25	1.18	1.14	1.11	1.07	1.05			1.04
	0.75	1.33	1.27	1.23	1.20	1.16	1.14			1.13
	0.5	1.64	1.57	1.54	1.50	1.46	1.44			1.43
100	1	0.35	0.35	0.34	0.34	0.33	0.32			0.32
	0.75	0.38	0.38	0.37	0.36	0.35	0.35			0.35
	0.5	0.47	0.47	0.46	0.45	0.44	0.44			0.44

auger holes that are empty, one-fourth full and half full. For each of these 21 cases, C values are shown for auger hole with an impermeable barrier at various dimensionless distances S/H .

SPECIAL APPARATUS (Figure 2)

1. Soil auger or a commercial drilling rig.
2. Permeable material for casing the auger hole to prevent caving. Materials used for casing auger holes may be thin perforated sheet metal pipe, perforated stovepipe, drain tile, thin perforated PVC Pipe, etc.
3. Water elevation indicator. The indicator device consist of a float lowered into the auger hole and connected to a counter weight with a tape. This tape is mared, at equal time intervals, as the water level rises in the auger hole.

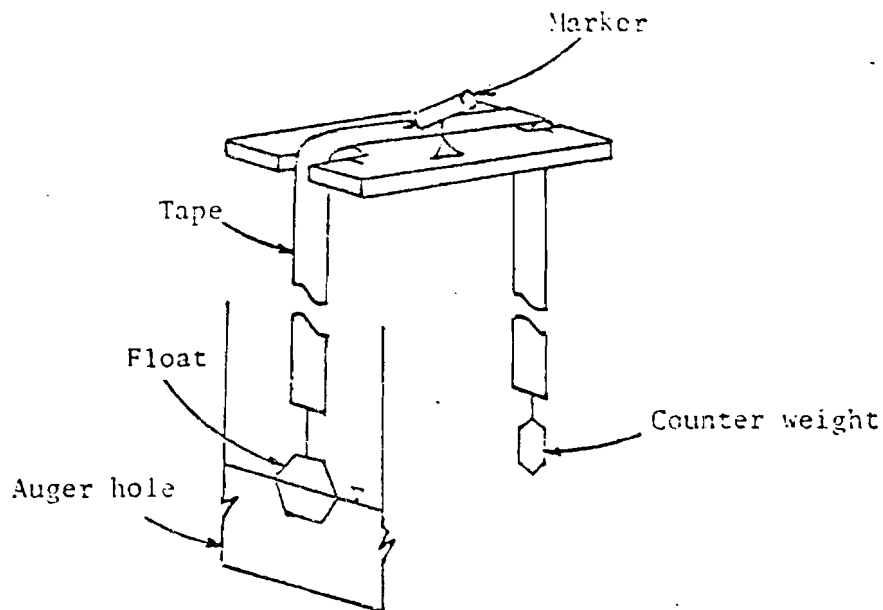

Figure 2. Water elevation indicator device.

4. Pump system to quickly removing water from the auger hole.

PROCEDURE

In the following discussion, the installation of the auger hole (Steps 1 through 4) is done before determining the hydraulic conductivity. Successive steps (5 through 9) are done several times so that more than one estimate of the hydraulic conductivity can be made.

1. A vertical hole is dug with a soil auger or by another method to the desired depth below the water table.
2. Install the permeable case in the hole, leaving the end of the case several centimeters above the soil surface. The pipe or tile used as a casing should be back-filled properly to insure free flow of groundwater into and out of the auger hole. The proper way to install the casing is to place a small quantity of gravel on the bottom of the hole and set the open pipe on this gravel. Gravel is then back-filled around the pipe to a level above the water table. The original soil can be used to fill the remaining portion of the hole around the pipe to the soil surface. The auger hole should be capped for protection.
3. Pump the hole several times until clean water is obtained.
4. Allow the water to seep into and fill the auger hole to the level of the water table. This will require at least a day for heavy, tight soils. In the case of permeable sand soils, only a few minutes are needed.
5. When the water in the auger hole is at water table level, lower the float into the auger hole and mark a datum point on the tape.
6. Pull the float out of the auger hole.
7. Pump out or bail the water quickly.
8. Lower the float into the auger hole and mark the tap at frequent, equal, time intervals as the water level rises in the auger hole.
9. From the datum point, determine the distance y .

CALCULATIONS

Table 1 enables one to determine the hydraulic conductivity of a soil K , from measured values of the rate of water rising in the auger hole $-dy/dt$, and the relationship expressed in Equation 2. Intermediate values of C can be obtained by interpolation. For accurate work use logarithmic interpolation of C , and H/r at some known value of y/H , as explained below.

Sample calculation

To show the calculation, we present an example in Figure 3.

The readings of water level in the auger hole y as a function of time were:

<u>Time (sec)</u>	<u>y (cm)</u>
10	106
20	93
30	81
40	69
50	59
60	48
70	40
80	33
90	26
100	21

According to Figure 3a $H/r = 30$, y/H is taken at 0.5 and the depth to the impermeable barrier, S , is not known. We therefore estimate C for the two extreme cases i.e., $S = 0$ and $S = \infty$. Since we do not have values of C corresponding to an H/r of 30 in Table 1 a logarithmic interpolation is required (Figure 4). It is found that the value of C corresponding to an H/r of 30 is between 3.21 ($S = \infty$) and 3.80 ($S = 0$). We therefore choose a value between these two extremes say, $C = 3.51$.

The rate of change in the height of water in the auger hole, obtained in Figure 3b was $-dy/dt = 1.22$ cm/sec. Thus, using the above values in Equation 2 we find the hydraulic conductivity.

$$K(\text{m/day}) = (1.22)(\text{cm/sec})(3.51) = 4.28 \text{ m/day.}$$

COMMENTS

The advantages of using the auger hole method for hydraulic conductivity determinations are as follows:

1. The soil is not disturbed (original conditions in the field).
2. The "sample" is large and takes into account many types of water channel in the soil.
3. The fluid used is the soil solution itself and not tap water or distilled water having unknown effects.
4. The method is not unduly time-consuming.

A series limitation inherent in the auger hole method is that the presence of a water table is required and preferably it should not be too low. This means that in most locations only a few opportunities for measurements are available each year, most probably in spring. In some locations the condition may be favorable all through the year; in others this method will never be applicable.

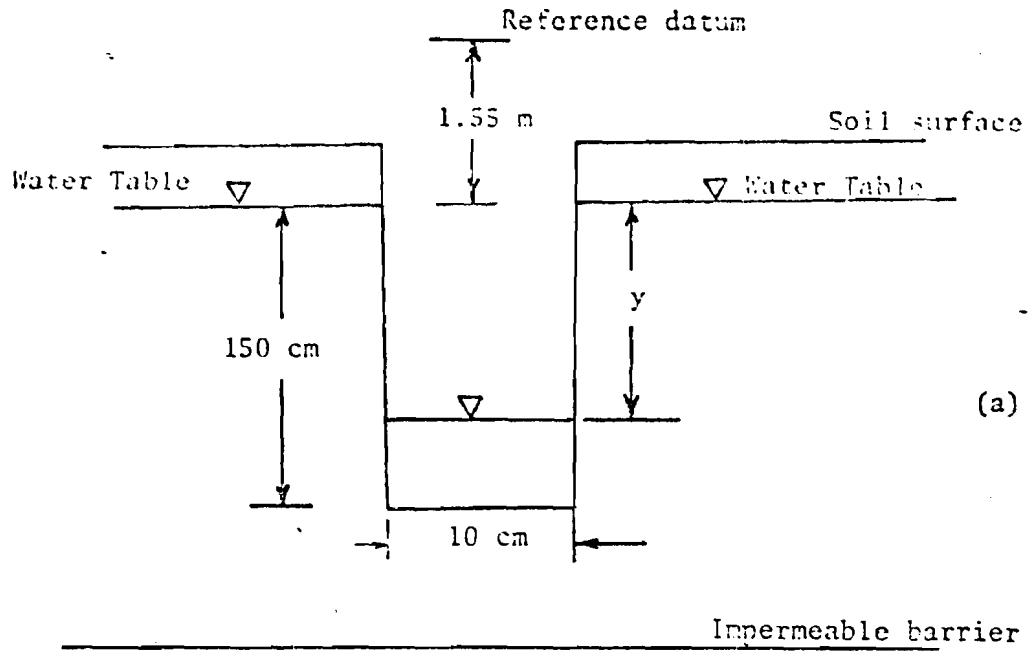

Figure 3a. Dimensions of the example auger hole.

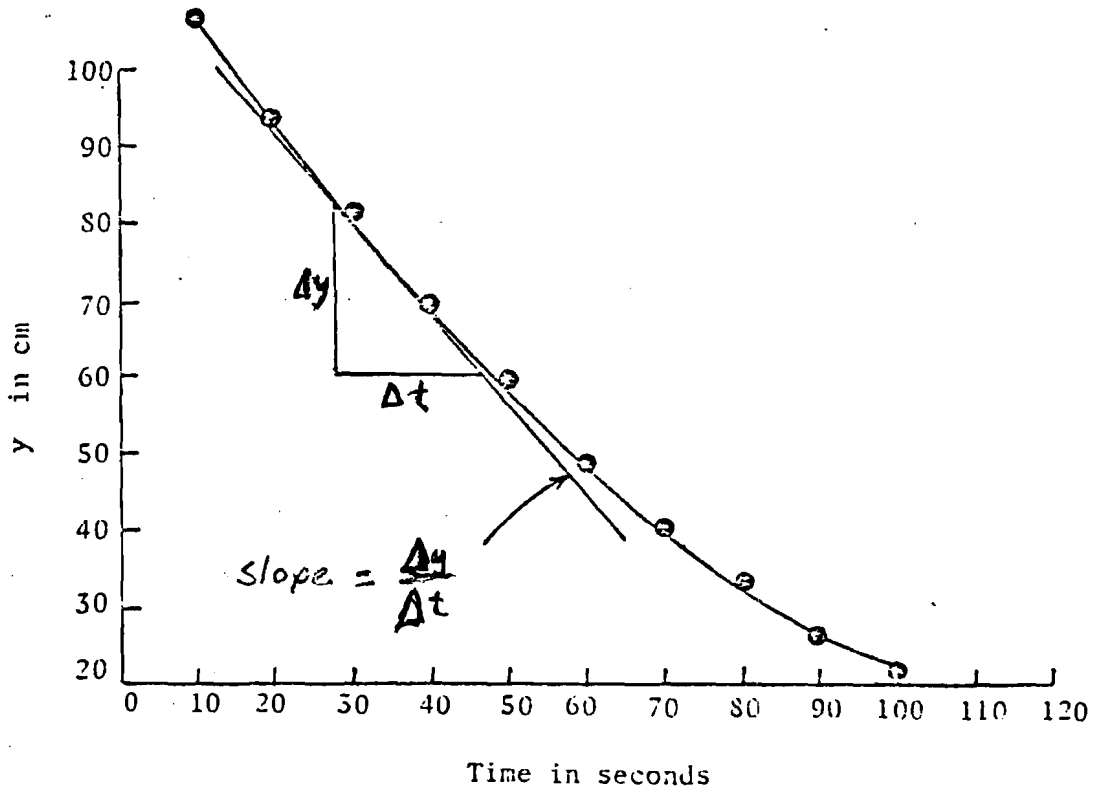

Figure 3b. Relationship between values of y and time.

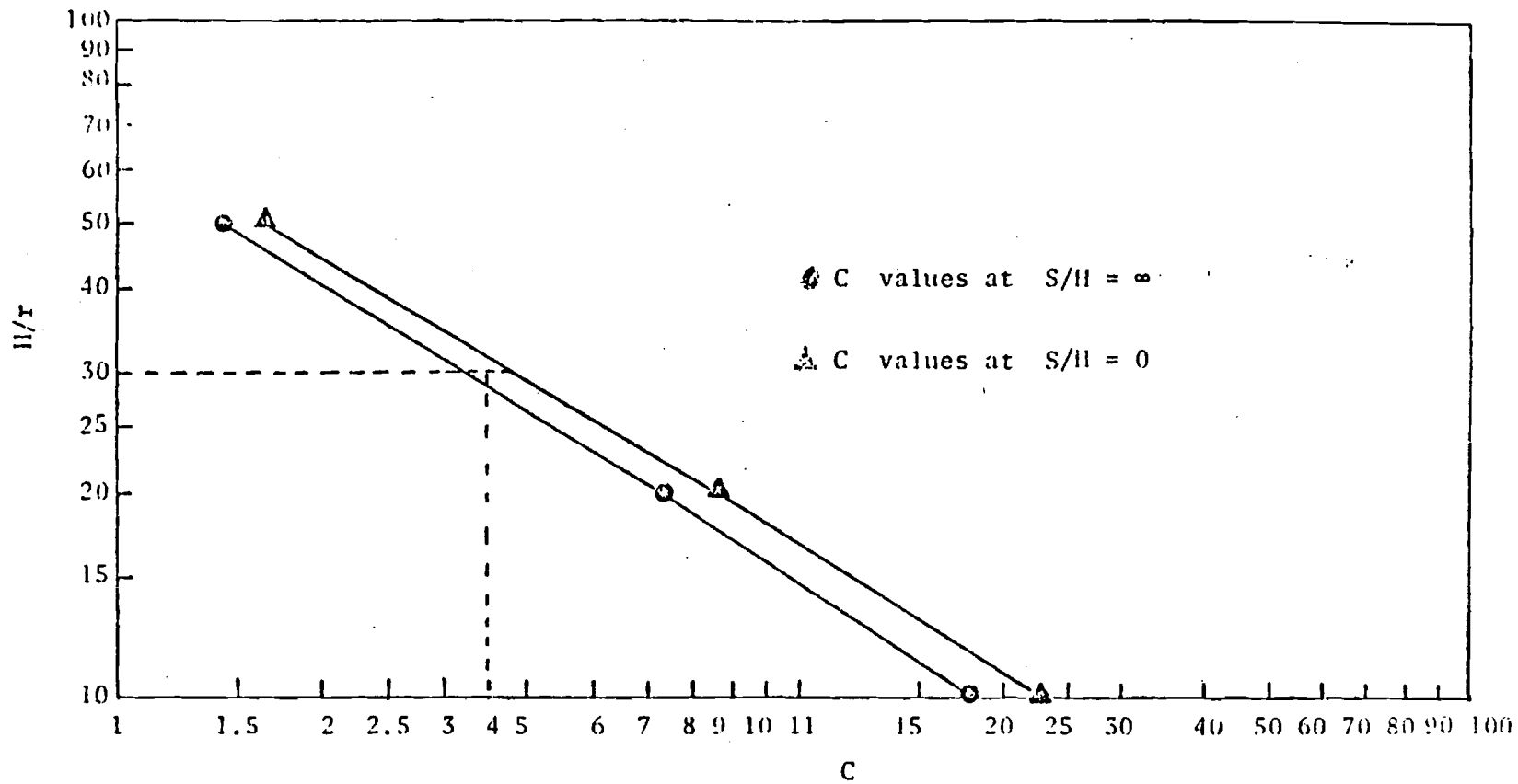

Figure 4. Logarithmic interpolation of C and H/r at $y/H = 0.5$.

EWUP

How to do it

Field Procedure



SOIL CLASSIFICATION

by L. Willardson and D. Sunada

INTRODUCTION

A bulk volume of soil may contain four major constituents, inorganic solids (minerals), organic solids, liquid (usually water), and air. Different soils contain varying amounts of each constituent and the nature of each constituent may vary. Soil classification is a systematic method of analyzing these constituents and describing the soil by use of standardized quantitative tests. Since the soil descriptions are based on definite tests, anyone using the classification systems should be able to arrive at the same soil classification.

Unfortunately, no single classification system is capable of describing all the significant aspects of a soil to every person who uses it. An adequate agricultural soil classification may present very little useful information to an agronomist or geologist. Therefore, each field of study involved with soils has its own (or several) classification system. The system presented here is that used by the United States Department of Agriculture, and is internationally used in agricultural studies.

SOIL TEXTURE

The USDA soil classification systems is based on soil texture, or the relative proportions of various size groups of mineral particles in a given soil. Inorganic soils may be divided into four components which are, in order of decreasing size, gravel, sand, silt, and clay. The limiting particle diameters for each of these components or soil separates is given in Table 1. The soil classification by finding the proportions by weight of sand, silt, and clay in the soil. Figure 1 is then entered and the intersections of the proper proportions determines the soil textural classification.

Table 1. Particle diameter of soil separates.

Soil Separate	Particle Diameter (mm)
Gravel	2.0
Very Coarse Sand	2.0 - 1.0
Coarse Sand	1.0 - 0.5
Medium Sand	0.5 - 0.25
Fine Sand	0.25 - 0.10
Very Fine Sand	0.10 - 0.05
Silt	0.05 - 0.002
Clay	0.002

Adapted from p. 1-2, Section 15 - Irrigation, SCS National Engineering Handbook, USDA, 1964.

Example: A soil is found to have 12% sand, 53% silt, and 35% clay. The intersection of these proportions on Figure 1 lies in the zone marked silty clay loam.*

It is necessary to perform a grain size analysis on the soil to find its textural proportions. The simplest method of separating different sized particles is by passing them through a series of wire mesh sieves which are stacked in order of decreasing mesh openings. The soil is deposited on the top sieve and the stack is shaken. The particles smaller than the mesh opening will pass through and fall on the next finer mesh. When the soil has been properly shaken, the sieves may be taken apart and the amount of soil retained on each sieve may be weighed. Using this information, the percentages may be computed.

This system works satisfactorily for the coarse sized particles, the sands, and gravels. The weight of the finer particles is so small that they generally do not pass through the small mesh openings. The finest sieve that these particles will normally pass is the #200 sieve which has openings of 0.074 mm. They may also adhere to the sides of the coarse particles and can affect the accuracy of the weighings of that fraction. Ways have been developed to deal with both of these problems.

To make an accurate analysis of the coarse fraction, the fine portion of the soil may be washed away so that the coarse fraction is left. This is normally accomplished by placing the soil on a #200 sieve mesh and spraying water through the mesh and soil. The soil is then dried and a normal sieve analysis can be run on the remaining material.

*The following two pages are from Chapter I--Soil-Plant-Water Relationship, Section 15 - Irrigation, Soil Conservation Service National Engineering Handbook, U.S. Department of Agriculture, 1964.

The grain size analysis is usually conducted on the fine fraction of the soil by means of a hydrometer analysis. In this test, the fine fraction of a soil is carefully mixed in a cylinder full of water and the mixture is allowed to settle with time. As the soil particles settle, the specific gravity of the mixture changes. The amount of material still in suspension can be estimated by the difference between the specific gravity of the mixture and the specific gravity of just the liquid without the soil particles.

The specific gravity is measured by a hydrometer, a glass bulb with a stem which has a calibrated scale inside it. The hydrometer is placed in the mixture and the scale in the stem is read. This reading gives an indication of the amount of soil in suspension. The diameter of the soil particles is approximated by use of Stokes Law which relates the velocity of a particle fall in a liquid to its diameter. Therefore, the test consists of taking measurements of the specific gravity to find the percent of material in suspension at particular times to determine the particle diameter.

EWUP

How to do it

Field Procedure



SOIL PARTICLE SIZE ANALYSIS BY THE HYDROMETER METHOD

by L. Willardson

Particle size analysis can be made by the hydrometer method for soils having particles smaller than a number 40 (0.425 mm) screen. Sieving is normally used if most of the particles are larger than a number 200 (0.075 mm) screen. The hydrometer method is used if most of the particles are smaller than a number 200 screen.

General Procedure

A known weight of soil is thoroughly mixed and dispersed in a known volume of water. The specific gravity of the soil-water suspension is measured with a hydrometer. As the larger heavier soil particles settle out of the solution, the specific gravity of the suspension decreases. A correlation related to the settling velocity of particles is made between time and the specific gravity.

Equipment Needed

1. Stirring apparatus
Mechanical device or air-jet device
2. Hydrometer - either type
Type 151H - Calibrated to read specific gravity 1.000 in distilled water at 20 degrees C
Type 151H - Calibrated in grains of soil per liter (-5 to +60 g/liter)
3. 1000 ml sedimentation cylinder
4. Thermometer accurate to 0.5 C
5. Water bath or constant temperature room

Detailed Procedure

For the hydrometer analysis the sample of all material passing the 2 mm sieve (No. 10) should be about 115 g for sandy soils and 65g for silt and clay soils. Determine the hygroscopic moisture correction factor by weighing out a 10 to 15g portion of the air dried soil and drying in a 110 C oven

to a constant mass. The hygroscopic correction factor is the ratio of the mass of the oven dried sample and the mass of the air dried sample.

The remaining 50 to 100g of a carefully weighed air dried sample is placed in a 250 ml beaker and covered with 125 ml of recently prepared sodium hexametaphosphate solution buffered with sodium carbonate to a pH of 8 or 9 (40 g/liter). Stir and allow to soak 12 to 16 hours (sodium hexametaphosphate buffered with sodium carbonate is marketed as "calgon").

Transfer the soaked soil to the stirring apparatus. If the mechanical stirrer is used, additional distilled water should be added to the dispersion cup to fill it more than half full. Stir for one minute.

Care should be taken that all soil is transferred from the dispersion device to the sedimentation cylinder. Distilled water is added to bring the total volume in the sedimentation cylinder to 1000 ml.

The test is started by covering the end of the cylinder with the palm of the hand and tipping the cylinder upside down and back for one minute (30 times). Make sure that all the soil at the bottom of the cylinder is loosened and in suspension. Place the cylinder in a convenient place in the constant temperature room. Hydrometer readings taken at the following intervals of time: 2, 5, 15, 30, 60, 250, and 1440 minutes after the beginning of sedimentation. The hydrometer is slowly immersed in the soil suspension about 30 seconds before each reading to allow it to come to rest before the reading time. Read the hydrometer at the top of the meniscus formed by the suspension around its stem. The reading shall be made to the nearest 0.005 specific gravity for hydrometer type 151-H or the nearest 0.5g per liter for the type 152-H hydrometer. After each reading carefully remove the hydrometer and place it with a spinning motion in a graduate of clean water. Measure and record the temperature of the suspension after each hydrometer reading.

After making the final hydrometer reading, wash the suspension on a 0.075 mm (No. 200) sieve. Dry the fraction retained on the sieve and separate into fractions using 0.425 mm and 0.075 mm sieves and such additional sieves as required. Record the masses retained.

Calculations

Calculate the oven-dried mass of soil used in the hydrometer analysis by multiplying by the hygroscopic moisture correction factor.

Calculate the mass of the total sample represented by the mass of soil used in the hydrometer test by dividing the oven dry mass of the hydrometer

sample by the percent of the total sample passing the 2 mm (No. 10) sieve and multiplying by 100. The mass obtained is W in the formulas for calculating the percent remaining in suspension at the level where the hydrometer measures the density of the suspension.

When the 151-H hydrometer is used, P is calculated from:

$$P = \left(\frac{100,000}{W} \frac{G}{G - G_1} \right) (R - G_1)$$

For the 152-H hydrometer the percentage in suspension is:

$$P = \frac{Ra}{W} \times 100$$

Where: a = correction factor for the 152-H hydrometer reading
 P = percentage soil remaining in suspension at the level where the hydrometer measures the suspension density
 R = hydrometer reading after subtracting the composite correction defined below
 W = oven dry mass of soil in the total test sample represented by weight of soil dispersed (defined in previous paragraph)
 G = specific gravity of soil particles
 G_1 = the specific gravity of the liquid ($G_1 = 1.00$)
 R = the hydrometer reading (i.e., 1.025)

To obtain the composite hydrometer correction prepare a 100 ml of distilled water and dispersing agent in the same proportion as in the sedimentation test. Place the hydrometer in this mixture and read the top of the meniscus. For the type 151-H hydrometer the composite correction is the difference between the reading and 1.000. For the 152-H hydrometer it is the difference between the reading and zero. The correction is temperature dependent and should be established for the range of temperatures expected in the sedimentation test.

The diameter of particle corresponding to the percentage P above is calculated using Stokes' Law for drag forces on a sphere settling under viscous conditions.

$$F_d = 3\pi\mu VD$$

where F_d is the drag force, μ is the viscosity of the fluid, V is the particle full velocity, and D is the diameter of the sphere. At the terminal velocity, F_d is the buoyant weight of the particle.

$$F_c = (\gamma_s - \gamma_w) \pi D^3 / 6$$

where γ_s and γ_w are the unit weights of the particles and water.

Solving for D,

$$D = \sqrt{\frac{18\mu}{\gamma_s - \gamma_w}} \sqrt{V} \quad \text{or}$$

$$D_{\text{mm}} = K \sqrt{L/T}$$

where L is the fall distance of the particle measured in centimeters from the water surface to the center of buoyance of the hydrometer (see Table 2) and T is the time of the reading in minutes (also the fall time). The factor, K, is a function of temperature and specific gravity of the particles. Values of K are tabulated in Table 3.

Table 1. Correction factor "a" for specific gravity (hydrometer 152H).

G	"a"	G	"a"	G	"a"
2.95	0.94	2.75	0.98	2.55	1.02
2.90	0.95	2.70	0.99	2.50	1.03
2.85	0.96	2.65	1.00	2.45	1.05
2.80	0.97	2.60	1.01		

Table 2. Effective depth (L) vs. hydrometer reading.

Hydrometer 151H		Hydrometer 152H			
Reading	L(cm)	Reading	L(cm)	Reading	L(cm)
1.000	16.3	0	16.3	32	11.1
1.002	15.8	2	16.0	34	10.7
1.004	15.2	4	15.6	36	10.4
1.006	14.7	6	15.3	38	10.1
1.008	14.2	8	15.0	40	9.7
1.010	13.7	10	14.7	42	9.4
1.012	13.1	12	14.3	44	9.1
1.014	12.6	14	14.0	46	8.8
1.016	12.1	16	13.7	48	8.4
1.018	11.5	18	13.3	50	8.1
1.020	11.0	20	13.0	52	7.8
1.022	10.5	22	12.7	54	7.4
1.024	10.0	24	12.4	56	7.1
1.026	9.2	26	12.0	58	6.8
1.028	8.9	28	11.7	60	6.5
1.030	8.4	30	11.4		

SEMI-LOG CHART FOR GRADING CURVES

Project _____
 Location _____
 Station _____
 Material _____
 Sample No. _____

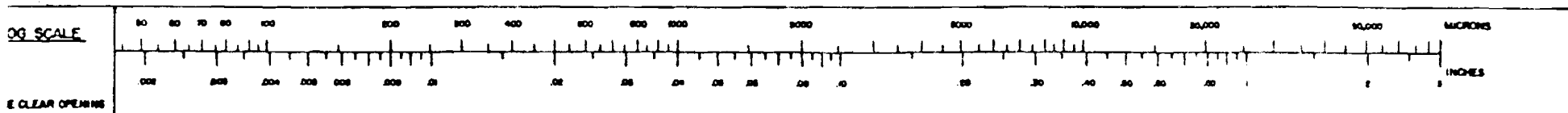
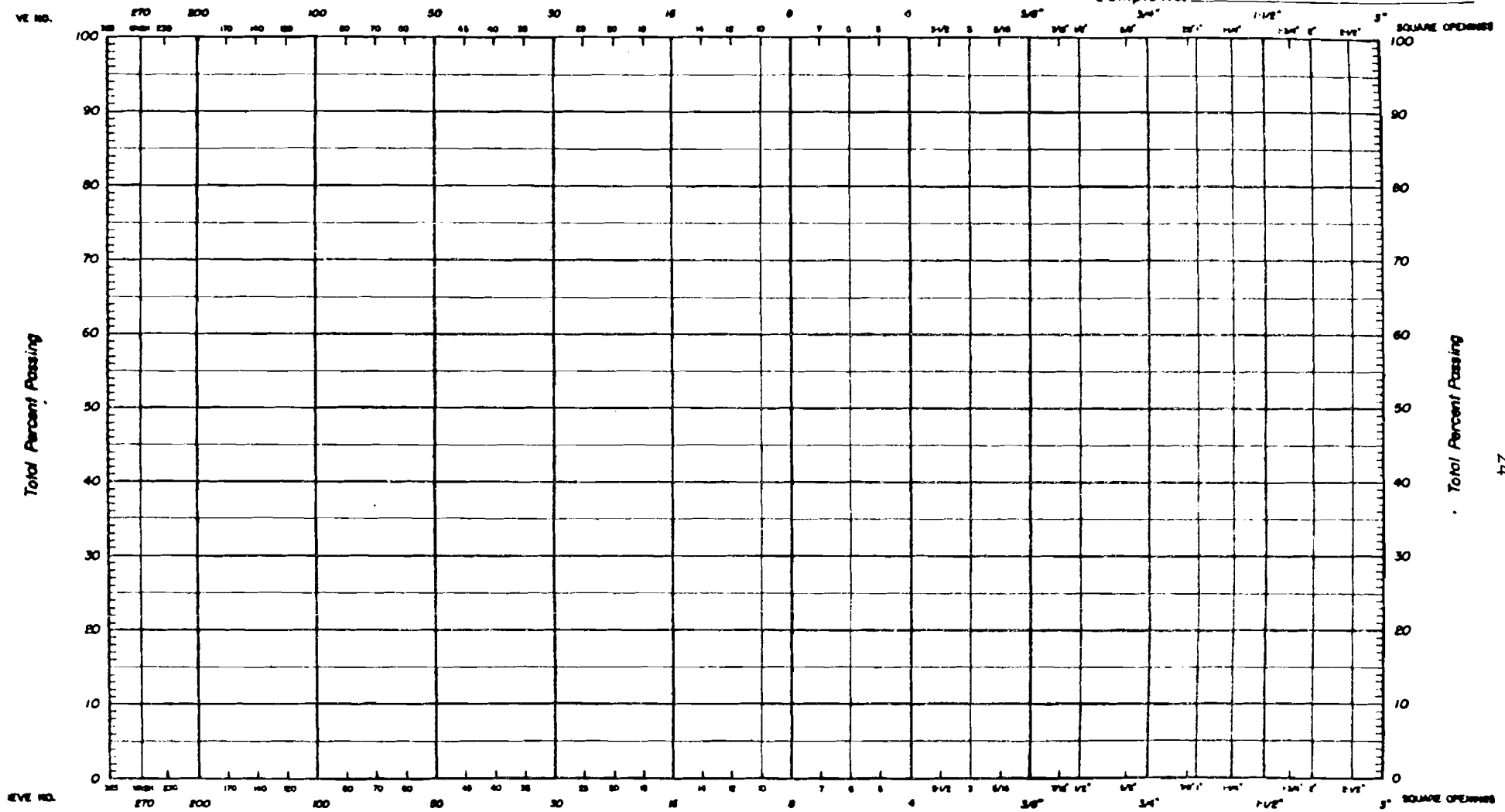

U.S. STANDARD SIEVES - A.A.S.H.O. METHOD T-27

BEST AVAILABLE COPY

88

EWUP

How to do it

Field Procedure



PARTICLE SIZE ANALYSIS BY SIEVING

by L. Willardson

Determination of the particle size distribution of soils and gravel or sand drain envelope materials is important in drainage design. The information is needed to protect drains from clogging by sediment.

Particle size analysis for fine soils is usually done by the hydrometer method. Particle size analysis for sand, gravel or a coarse soil is done by sieving.

General Procedure

A representative sample of the material is air dried. The material is weighed and then shaken through a series of standard sieves of progressively smaller sizes. The amount of material retained on each sieve is weighed and a particle size distribution curve is plotted for identifying the material.

Equipment Needed

1. A balance of weighing device sensitive to 0.01 grams. The balance should be able to weigh at least 500 grams of material.
2. A set of standard sieves of sizes numbers: 4, 10, 20, 40, 80, 100, 200, and PAN. The corresponding sieve openings are: 4.75, 2.00, 0.850, 0.425, 0.180, 0.150, and 0.075 mm, respectively. The pan catches all material finer than a number 200 sieve. Other sizes besides those listed can be used as long as they cover the range of sizes adequately.
3. A sieve shaker. The sieves can be shaken by hand or by means of a sieve shaker machine. A cover is needed to prevent loss of material during shaking.

Detailed Procedure

1. A representative sample of the material should be air dried. Care should be taken to avoid separation of the material during handling to avoid getting too many large or small particles from the sample.
2. The sample should be carefully split or divided to obtain an average sample weighing 300 to 500 grams. A sample splitter can be used or

the sample can be divided by hand on a paper or plastic sheet. Care should be taken to avoid losing small or large particles from the sample.

3. The sample is weighed to the nearest 0.01 gram.

4. The sample is put into the top of a stack of sieves that become progressively smaller toward the bottom. The coarsest mesh sieve should be on top and the pan to collect the finest materials should be on the bottom.

5. The sieves should be jarred and shaken vertically and horizontally until there is less than a one percent change in the weight of the material on a sieve during one minute of shaking.

Overshaking can grind to powder the material on the screens.

The material should not be rubbed to make it go through the screens.

6. When shaking is completed, the amount of material retained on each screen should be weighed. The sum of all the weights should be nearly equal to the weight of material placed in the sieves at the beginning.

7. When the sieves are cleaned by brushing, care should be taken to avoid damaging the fine sieves.

8. The results appear as in the following table.

<u>Sieve Number</u>	<u>Opening mm</u>	<u>Weight Retained</u>	<u>Cumulative Retained</u>
4	4.75	0	0
10	2.00	0	0
20	0.850	9.10	9.10
40	0.425	16.95	26.05
80	0.180	23.40	49.45
100	0.150	17.30	66.75
200	0.075	3.90	70.65
Pan	--	1.32	71.97
Total		71.97	
Original Weight		72.00	
Loss		0.03 grams	

The cumulative weight retained is found by adding the weights retained on each screen progressively.

9. The percent of material finer is calculated by subtracting the cumulative weight retained from the total and dividing by the total. For example, the percent of material finer than the number 80 screen is:

$$\frac{71.97-49.45}{71.97} \times 100 = 31\%$$

Following this procedure, a table can be prepared of opening sizes and percent finer.

<u>Opening mm</u>	<u>Percent Finer</u>
2.00	87
0.850	64
0.425	31
0.180	7
0.150	2
0.075	0

10. The data are plotted on semi-log paper with the vertical linear axis as percent finer and the horizontal logarithmic axis as particle size or sieve opening.

A very steep curve indicates a uniform material. A flatter curve indicates a graded material. The usual soil particle size distribution curve has an "S" shape.

11. A soil classification triangle can be used to classify the soil from the data.

EWUP

How to do it

Field Procedure



CROP SURVEY METHODS

by M. B. Lowdermilk*

Most agricultural field workers have had some experience in crop survey methods. The purpose as related to command areas of farm irrigation systems is to document over time the crops cultivated in each farmer's field for each cropping season. Where three or more crops are cultivated in succession under intensive methods, the task is more complex. Also the task becomes more complex when more than one crop is cultivated in a single irrigation basin or a farmer's field.

Procedures Involved

1. First obtain or develop a precise map of the command area and measure the irrigation basins for each farm. This can be done by actual tape measurements or by pacing the field boundaries. If the pacing method is used each field investigator will need to calibrate his particular pace in terms of feet and inches or meters and centimeters per pace.
2. Select a section of the command area and station a person with a map near the center and use two persons making measurements and calling out the particular crop or crops in each unit as the party moves down a command area in a systematic manner.
3. Use codes for each crop such as W for wheat, F for Fallow, etc. as shown in Figure C attached.
4. If the field work map is of adequate scale and there are several crops in a given unit the recorder should enter the dominant crop above the others such as

*This How-To-Do-It was taken from The Problem Identification Handbook (April 1, 1980). Developed by the CSU-Pakistan Water Management Project sponsored by U.S. Agency for International Development, Contract No. AID/TAC-1100.

Ca = Cabbage

To = Tomatoes

W = Wheat

to indicate the dominant crop. If relay crops are used they can be noted as Co + Berseem to show that Berseem is interplanted in Cotton (Co).

5. The timing of crop surveys is important. For example, if the survey is done during the transition of crops invalid data will often occur because what appears fallow may be cultivated within a short period. In each area one must choose the best time for a particular crop survey.
6. Equally important is to return at the proper time in the crop cycle to record the next crop. If there are two distinct cropping seasons a decision can be made to enter the first crop as Co = Cotton/W = Wheat over the next crop. There is however often a problem because farmers change the size of their irrigation basins and fields often in relationship to the crops they cultivate at a given time. Also farmers rent-in and rent-out land from time to time.

Uses of Crop Survey Data

1. Providing a record of cropping intensities, patterns, and rotations over time.
2. Providing a record of intercropping and fallow over time.
3. Providing a record of shifts in field sizes and crops over time.

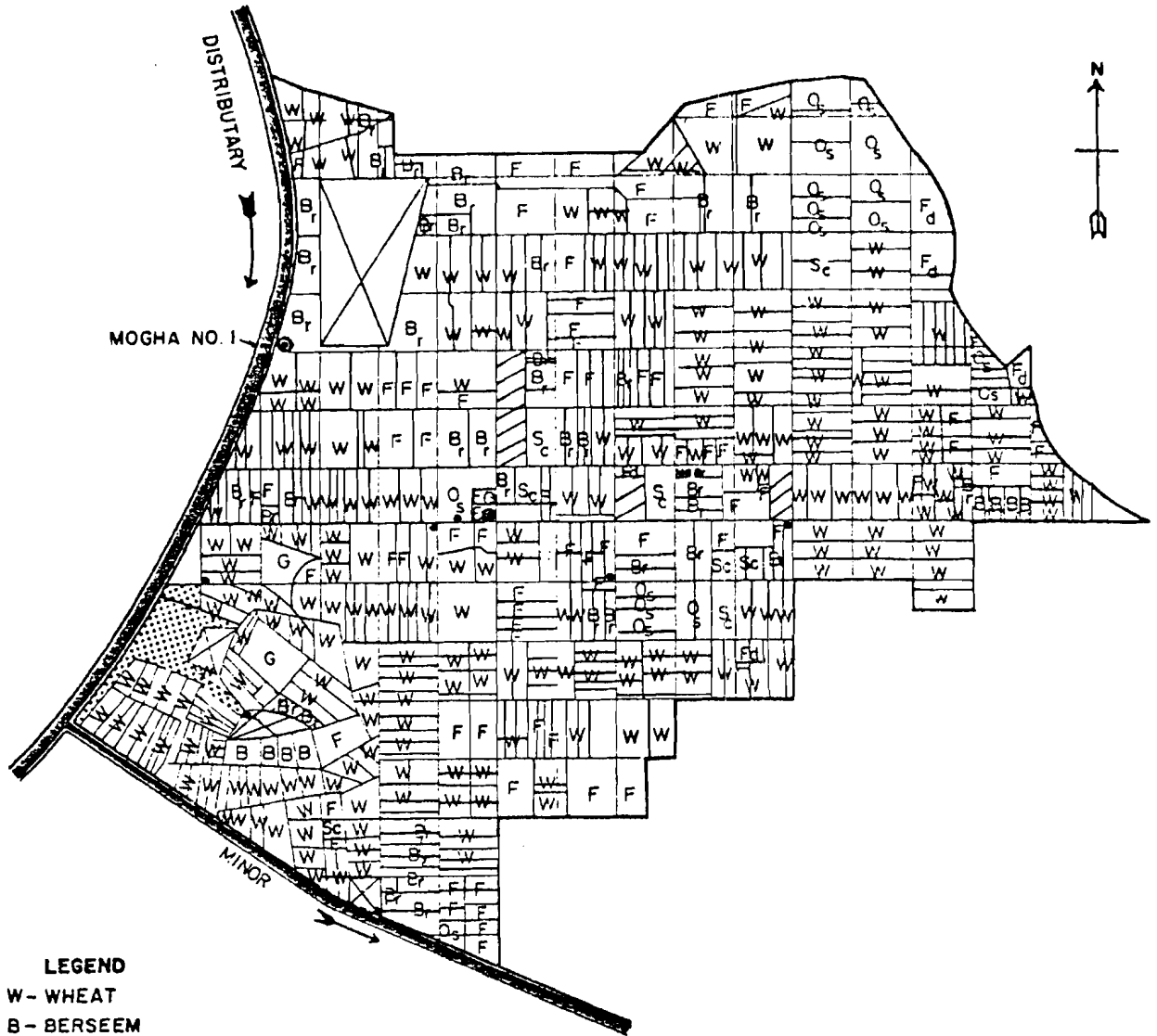

- LEGEND**
- W- WHEAT
 - B- BERSEEM
 - F- FALLOW
 - Sc- SUGAR CANE
 - Os- OIL SEED
 - Br- BARREN
 - Fd- FODDER
 - G- GARDEN
 - DISTRIBUTARY
 - MOGHA / TUBEWELL
 - HOUSE
 - MINOR
 - JHALAR
 - BUNDED UNIT BOUNDARY
 - AREA BOUNDARY
 - UNCULTIVATED BARREN

Scale- 0 220 440 660

WATER MANAGEMENT RESEARCH PROJECT

WATERCOURSE SURVEY SAMPLE VILLAGE: NUMBER 103

DISTRICT LAHORE

WATERCOURSE COMMAND I

CROPS

EWUP

How to do it

Field Procedure



MAPPING CROP STANDS

by Moslin Wahla and John Reuss *

Often data are required about the quality of crop stands. Usually these data are needed to determine the germination or emergence of a crop variety under different conditions such as fertility, salinity, moisture, composition, physical soil types, field levelness status, etc. depending on the specific purpose of the investigation.

Procedures to Use

1. Select the fields or irrigation basins according to some acceptable sampling method.
2. Decide on the areas within fields to be sampled on a random basis.
3. After the grid has been developed and the sampling frame, count the plants in the grided sample area. For example, if the unit is 20 feet by 20 feet count the plants in the 400 square foot area and record the data.

Example of Mapping Crop Stands to Determine the Influence of Field Levelness on Cotton Stands and Yields/Acre

The example given below is taken from a study to determine the effect of poorly leveled fields on crop productivity utilizing the elevation differences on stands and yields of cotton in 15 sample fields. The method and the results are presented from the work of Wahla and Reuss.

Fields were selected by Agricultural Extension workers during October 1975. Basis of selection was simply that the farmer was aware that a significant elevation difference existed within the field. Two plots, each twenty-foot square, were located so as to include the highest land within the field in one plot and the lowest land within the other. A middle elevation plot of the same size was selected between the high and low elevation

* This How-To-Do-It was taken from The Problem Identification Handbook (April 1, 1980). Developed by the CSU-Pakistan Water Management Project sponsored by U.S. Agency for International Development, Contract No. AID/TAC-1100.

areas. Extreme edges or dirt borrow areas were avoided and selection of the areas was made without regard to crop growth. In most cases elevation differences were determined by depth of water at the final irrigation. Where no irrigation was applied after plot selection, elevation differences were determined by means of dumpy level.

The number of stalks within each plot area was counted, and the cotton harvested from each plot at each picking date was weighed and recorded. To date most of the plots have been picked three times. Data collected to date are summarized in Table 1.

The low and mid elevation plots respectively averaged 4.6 and 2.2 inches lower than the high elevation plots. Thus, about 4.6 more inches of water were applied to the low elevation areas than the high areas. Yield data collection is not yet complete but preliminary analysis indicates a definite and major yield difference due to elevation within the field. Yields are generally very low, but in all cases, the yields from the low elevation plots are below those of the high and mid elevation plots. Average yield from the low elevation plots is only about one-half of that from the high and middle elevation plots. The probability that this difference is due to chance is less than 0.005. There is an apparent reduction in stands on the low lying plots, but this difference is less consistent than the yield difference.

The data will be subjected to additional analysis after the data collection is completed. However, the effect of excess water on the lowest areas appears unmistakable. Apparently major yield depressions on significant portions of these fields are being caused by lack of adequate leveling (see Table 1).

Such a method as described above can be used for several purposes as required by the investigator.

Table 1. Effect of elevation differences within fields on cotton stands and yields (3 pickings).

Plot No.	Elevation Difference			Stand			Yield		
	High	Mid inches*	Low	High	Mid Stalks/400 ft ²	Low	High	Mid lbs/acre	Low
1	0	2.2	3.4	191	172	182	370	522	265
2	0	3.1	4.7	120	108	82	291	443	269
3	0	2.1	4.3	82	170	21	232	389	174
4	0	2.0	4.0				291	160	58
5	0	2.0	4.0				138	79	65
6	0	1.0	3.0				450	291	196
7	0	2.0	3.7	123	136	82	545	689	199
8	0	2.5	4.0	38	34	28	302	384	98
9	0	2.0	4.0	70	196	65	365	436	215
10	0	3.2	6.0	77	76	41	545	806	178
11	0	3.2	10.6	73	71	48	334	163	73
12	0	1.5	4.0	96	78	29	291	204	87
13	0	2.5	5.6	143	157	80	370	395	174
14	0	1.5	4.0	180	87	80	482	552	225
15	0	2.0	4.0	119	143	122	901	668	596
Means		2.19	4.58	109	118	72	390	345	191

*Elevation below highest point.

EWUP

How to do it

Field Procedure



YIELD ESTIMATE METHODS

by M. B. Lowdermilk*

The following discussion will present a method of accounting for crop yield estimations. This format, though specifically designed for nonfodder crops such as rice, wheat, cotton, oats, etc., will put forth some generalized guidelines and procedures in which different types of crops can be measured in a manner that is relevant to them. In describing this format, three general dimensions making up the accounting format will be described and then how the yield per crop is calculated will be put forth.

To begin the process, the researcher will ask the farmer what he believes the estimated area under crop is and the estimated total units produced. These questions will provide a baseline figure from which to compare later calculations. The calculations are divided into three main categories: harvest costs, home consumption estimates, and the total quantity of units sold.

There are three types of harvest costs: direct costs, indirect costs, and other types of costs. Direct costs involve the costs that are placed on the activities that are an integral part of the immediate harvest; i.e. cutting, picking, threshing, winnowing/cleaning, bagging, transport, and storage. The indirect costs are payments to local artisans for services rendered in relation to the harvest. These payments will go to such people as the blacksmith, carpenters, shoemakers, barbers, religious leaders, laundryman, etc. Other costs involve payments for various reasons to local officers for services rendered during the harvest. Payments of this type go to agricultural officers, revenue agents, irrigation officials, and the like. These costs are in kind and they provide an indicator of what the farmer pays for the harvesting of the crop.

* This How-To-Do-It was taken from The Problem Identification Handbook (April 1, 1980). Developed by the CSU-Pakistan Water Management Project sponsored by U.S. Agency for International Development, Contract No. AID/TAC-1100.

The next dimension consists of the home consumption estimate. This entails what the home unit utilizes for its own subsistence plus any extra support that it may attain. Again the unit of measurement is in kind. A critical aspect of measuring this dimension is the establishment of the home unit. The researcher will have to include not only people, but also animals owned by the family who are fed by that family. In addition, a definition of what constitutes a full unit vs. a fractional unit must be ascertained. For instance are small children and the elderly equal to a middle aged adult in their consumptive patterns? Thus in defining a home consumption estimate, different sub-units in the household and on the farm must be delineated and then these units are added up and multiplied by a specific level of consumption per unit.

A third measurement involves the total quantity of units sold by the farmer. This measure, which is also labeled in kind, constitutes the total amount of crop sold by the farmer. This measure is then added to the other two measures to arrive at a total production figure.

Harvest Costs + Home Consumption Estimate + Total Quantity of Units Sold = Total Production (in kind)

After this figure is calculated, the researcher then checks this answer to the question asking the farmer to estimate the perceived total units produced. If the two answers vary by more than 5%, then the researcher should go through this accounting procedure again. If it continues to be that much different, an examination of why the farmer perceived what he did should follow. Dividing the total production by the area cropped will give the researcher the yield per unit area of a particular crop for a particular farmer.

$$\frac{\text{Total Production}}{\text{Area Cropped}} = \text{Yield/Unit Area}$$

Additional checks to this accounting procedure involve getting an estimate of production from several persons in the family and measuring the area cropped when possible. What is of critical importance is that the researcher must know the area and the crops raised and also he should be aware of the various inputs placed into the system in order to have that crop grow. This accounting method is only a rough procedure, but it does serve as a check to an individual's perceived estimate of what he is producing.

EWUP

How to do it

Field Procedure



CONSUMPTIVE USE

by William Franklin*

INTRODUCTION

The total evaporation occurring from soil and plant surfaces and the plant transpiration (evaporation from the parenchyma cells through stomatal cells) is called evapotranspiration (ET). In addition to ET, plants will use a small amount of water in tissue building. The sum of the ET and the water use in tissue building is called consumptive use. However, because the water removed in plant tissues is usually very small compared to ET, the terms consumptive use and evapotranspiration are commonly used interchangeably.

When the evapotranspiration rate of a particular crop is not limited by soil water availability, and when the crop is growing vigorously with full foliage, it is called potential evapotranspiration (E_{tp}). Potential evapotranspiration is usually defined for a "reference" crop and is regarded as a function of climatic factors only.

Evapotranspiration for a crop may be greater or less than that for the reference crop due to various environmental factors. This is referred to as actual evapotranspiration (E_t). The ratio of E_t/E_{tp} (when soil water is not a limiting factor) is called the crop coefficient. When soil water is limiting, the evapotranspiration will decrease, and a "stress" factor (K_s) term is introduced. An empirical equation to evaluate K_s has been proposed by Kincaid and Heermann (1974).

COMPUTING EVAPOTRANSPIRATION

A review of the alternative approaches to estimating the volume and rates of water evaporated from wet crop and soil surfaces or transpired by the plants can be found in several literature sources (Jensen, 1973;

* This How-To-Do-It was taken from The Problem Identification Handbook (April 1, 1980). Developed by the CSU-Pakistan Water Management Project sponsored by U.S. Agency for International Development, Contract No. AID/TAC-1100.

Doorenbos and Pruitt, 1977; Horton, 1973). As far as this technology is applicable to the management of irrigation return flow quality (through irrigation scheduling), Skogerboe et al. (1974b) and Jensen (1975) are good summaries.

There are many methods by which evapotranspiration can be calculated, however, the three most common approaches for estimating evapotranspiration are (1) the Blaney-Criddle method; (2) the Modified Jensen-Haise method; and (3) the Penman Combination method. These methods represent much of the range in sophistication available today, varying in detail from a temperature dependent analysis (Blaney-Criddle) to an analysis of energy balance and convective transport (Penman). It should be noted that both the Jensen-Haise and Penman equations are calculated in $\text{cal cm}^{-2}\text{t}^{-1}$ and can then be converted to an equivalent depth of evaporation by dividing by an assumed value for the latent heat of vaporization of 585 cal gm^{-1} , which yields units of length over time. This conversion is:

$$E_{tp} \times 0.0017 \rightarrow \text{cm t}^{-1}$$

$$E_{tp} \times 0.000673 \rightarrow \text{in t}^{-1}$$

The Blaney-Criddle Method

The Blaney-Criddle procedure for estimating evapotranspiration has the form (Blaney and Criddle, 1950):

$$E_t = \frac{k_t k_c t p}{100} \quad (1)$$

where:

$$E_t = \text{monthly evapotranspiration in inches;} \quad (2)$$

$$k_t = 0.0.173t - 0.134$$

$$k_c = \text{time distributed crop growth stage coefficient;} \\ t = \text{mean monthly temperature in } ^\circ\text{F}; \text{ and} \\ p = \text{mean monthly percentage of annual daytime hours.}$$

Crop curves and values for p can be found in Blaney and Criddle (1950) and USDA Soil Conservation Service, Technical Report 21. Estimates of E_t were originally intended on a seasonal basis, but work by numerous individuals have shortened this interval by interpolating values for p and k_c .

The Modified Jensen-Haise Method

The Jensen-Haise procedure is a temperature and solar reduction equation adjusted for location and elevation by vapor pressure functions (Jensen and Haise, 1963):

$$E_{tp} = C_t (T - T_x) R_s \quad (3)$$

in which,

E_{tp} = average daily potential evapotranspiration of a well-watered alfalfa crop having 30 to 50 cm of top growth, mm/day;

T = mean daily temperature, °C;

R_s = total daily solar radiation in langleys multiplied by 0.0171 to get mm/day;

T_x = intercept of the temperature axis

$$= -2.5 - 0.14 (e_2 - e_1) \text{ } ^\circ\text{C}/\text{mb} - \text{elev}(\text{m})/550 \quad (4)$$

e_2, e_1 = saturation vapor pressures at the mean maximum and mean minimum temperature, respectively, for the warmest month of the year, in mb/

C_T = temperature coefficient

$$= \frac{1}{C_1 + C_2 \frac{C_H}{C_H}} \quad (5)$$

$$C_1 = 38 - (2^\circ\text{C} \times \text{elev}/(\text{m})/305) \quad (6)$$

$$C_2 = 7.6^\circ\text{C} \quad (7)$$

$$C_H = \frac{50 \text{ mb}}{(e_2 - e_1)} \quad (8)$$

In order to relate E_{tp} to evapotranspiration values for other crops, a crop growth stage coefficient was defined,

$$k_{co} = E_t/E_{tp} \quad (9)$$

where

k_{co} = crop growth stage coefficient; and

E_t = potential evaporation for the specified crop

Kincaid and Heermann (1974) present polynomial regression equations for k_{co} based on the table of coefficients presented by Jensen (1973).

The Penman Combination Method

Penman (1948) first derived an equation for the evapotranspiration of a short, well-watered crop (generally assumed to be grass) based on a combination of energy balance at the crop surface and the heat-mass transfer processes due to air movements. The equation which resulted and is used today is written for alfalfa:

$$E_{tp} = \left[\frac{\Delta}{\Delta + \gamma} (R_n + G) + 15.36 \frac{\Delta}{\Delta + \gamma} (a + bU_2)(e_z^o - e_z) \right] - 0.0171 \quad (10)$$

in which,

- Δ = slope of the saturation vapor pressure curve at a specified temperature, d(mb)/d(°C);
 γ = psychrometric constant, mb/°C;
 R_n = net radiant energy, langleys/day (ly/day);
 G = soil heat flux, ly/day;
 U_2 = wind run at a height of 2 meters, km/day;
 a, b = empirical regression coefficients requiring local calibration;
 e_z^o = saturation vapor pressure at the surface of the crop, mb; and
 e_z = vapor pressure at the crop surface, mb.

The data available at most irrigated sites employing the Penman approach include solar radiation (R_s), temperature, wind, and relative humidity or dew point temperature. In order to develop the parameters for Equation 10 a number of empirical functions can be used. In the Grand Valley of western Colorado, the approach that was used is described below.

Net radiation, R_n , was determined from relationships presented by both Jensen (1973) and Kincaid and Heermann (1974). This procedure begins by defining solar radiation on a clear, cloudless day by plotting a curve through the long-term maximal values:

$$R_{so} = 760 \exp\left[-\left(\frac{\text{Day}-107}{167}\right)^2\right] \quad (11)$$

where

- R_{so} = clear day solar radiation, ly/day; and
 Day 1 - March 1.

A more recent review of Equation 11 indicates the coefficient 760 should be increased about 10 percent, but the overall effect is negligible. In a similar view, it is necessary to define the clear day net outgoing longwave radiation:

$$R_{bo} = \epsilon' \sigma T_k^4 \quad (12)$$

where

- R_{bo} = net clear day outgoing longwave radiation, ly/day;
 $\epsilon' = -0.2 + 0.261 \exp[-7.77 \times 10^{-4} (273 - T_k)^2]$ (13)
 T_k = temperature in degrees Kelvin (°C + 273)
 σ = Stefan-Boltzmann constant = 11.21×10^{-8} ly/°K

Based on Equations 11 and 12, the longwave radiation occurring on a particular day equals (Jensen, 1973):

$$R_b = \left[1.2 \frac{R_s}{R_{so}} - 0.2 \right] R_{bo} \quad (14)$$

and

$$R_n = (1-\alpha) R_s - R_b \quad (15)$$

in which α = crop albedo (generally taken to be 0.23).

The exchange in heat from the soil is based on two assumptions: (1) the soil temperature to a depth of 2 meters varies approximately with average air temperature; and (2) the volumetric heat capacity of the soil is $0.5 \text{ cal cm}^{-3} \text{ }^\circ\text{C}^{-1}$. The soil heat flux, G , is then written as (Jensen, 1973):

$$G = \frac{\bar{T}_{i-1} - \bar{T}_{i+1}}{t} \times 100 \quad (16)$$

where,

G = soil heat flux, ly/day;

\bar{T}_{i-1} = mean temperature for the previous period, $^\circ\text{C}$;

\bar{T}_{i+1} = mean temperature for the following period, $^\circ\text{C}$; and

Δt = days between the preceding and following periods (period interval).

Kincaid and Heermann (1974) use of comparison of current temperature with the average of the previous 3 days to calculate G for irrigation scheduling. They also present convenient expressions for $\Delta/\Delta+\gamma$, $\gamma/\Delta+\gamma$, and e_z^o as follows:

$$\gamma/\Delta+\gamma = 0.959 - 0.0125T + 0.00004534T^2 \quad (17)$$

$$\Delta/\Delta+\gamma = 1 - (\gamma/\Delta+\gamma) \quad (18)$$

$$e_z^o = -0.6959 + 0.2946T - 0.005195T^2 + 89 \times 10^{-6}T^{-3} \quad (19)$$

in which T represents the mean daily temperature in $^\circ\text{F}$.

The elevation of the term $(e_z^o - e_z)$ in the Penman equation can be made in several ways. For the Grand Valley studies, the following expression was used:

$$(e_z^o - e_z) = \frac{e_2^o + e_1^o}{2} - e_1^o \times rh \quad (20)$$

in which

e_2^o, e_1^o = saturation vapor pressure at maximum and minimum temperatures, mb; and

rh = maximum relative humidity (usually taken as the 6-8 AM values) expressed as a fraction.

MEASUREMENT OF EVAPOTRANSPIRATION

Consumptive use of water in a water balance computation of an irrigated area is one of the major components of the budget. It is, therefore, necessary that this value be determined as accurately as possible, and it is imperative that the evapotranspiration estimating formulas be calibrated for local conditions. Attempts to base conclusions on uncalibrated consumptive use equations would be extremely presumptuous, as will be explained later in this section. Tanner (1967) and the World Meteorological Organization (WMO) Technical 1, Note No. 83 (1966) provide a very good review of the procedure and methodology used for the measurement of potential evapotranspiration in the field.

Measurement of evapotranspiration should include the means for the actual measurement of consumptive use and, in addition, a complete weather station to measure air temperature (plus data, maximum and minimum) dew point temperature, relative humidity, precipitation, wind run, solar and net radiation and evaporation (Class A pan). Doorenbos (1976) presents an excellent discussion on the establishment and operation of a weather station for agricultural studies and the calibration of empirical ET indexes to actual ET measurements. WMO (1971) and WMO (1970) also present much information on the collection and analyses of hydrometeorological data.

Lysimetry

Probably the most accurate measurement of ET is obtained by the use of lysimeters. Lysimetry is the only method of measuring evapotranspiration where the investigator has complete knowledge of all the terms of the water balance equation. Harrold (1966) presents a very good review of the use of lysimeters for measuring ET. Horton (1973) has compiled an annotated bibliography on Et which includes lysimetry.

A lysimeter is a device which is hydrologically isolated from the surrounding soil. This device contains a volume of soil (which is usually planted to vegetation) and some means to measure the consumptive use (described below). Lysimeters must be representative of the surrounding conditions if they are to provide useful ET measurements. They must be representative of the soil type.

Two types of lysimeters, which have worked quite well for calibration purposes, are the constant water table lysimeter and hydraulic weighing lysimeters. The constant-water table lysimeter are usually planted to grass

(such as Kentucky Bluegrass) or other crops with shallow root systems. On the other hand, the hydraulic weighing lysimeters are usually planted in deeper rooted crops such as alfalfa or corn. The reference crops used in the calculations, which are usually planted in lysimeters, are generally considered to be well-watered grass or alfalfa.

Construction of a constant water table lysimeter is shown in Figure 1. They are usually about 1 meter square and about 60 cm deep. The amount of water use is calculated by using an area ratio of the lysimeter to the reservoir. The evapotranspiration rate is very sensitive to the depth of the water table in the lysimeter (usually kept at about 15 cm from surface for grass). In addition, the crop must be trimmed periodically to insure vigorous growth, and any vegetative growth extending beyond the sides of the lysimeter should be trimmed back.

Construction of the hydraulic weighing lysimeters are shown in Figure 2, and a typical calibration curve is shown short a time period does not give complete confidence in the resulting equations because temperature is only one of many climatic factors affecting evapotranspiration. A longer term analysis is needed before proposing a usable function for k_t beyond that expressed in Equation 2.

Jensen-Haise Calibration

In the Grand Valley, the mean minimum and mean maximum temperatures at the 1480 meter elevation are 346.°C and 18.1°C, respectively. At these temperatures, $e_2 = 55.29$ mb and $e_1 = 20.58$ mb so that $C_H = 1.44$. The data similarly result in C_T being equal to 0.0255 and $T_x = -10.05$. The Jensen-Haise equation for the Grand Valley is, therefore, (multiplied by 0.0171 to yield mm/day):

$$E_{tp} = 4.36 \times 10^{-4} (T + 10.05) R_s \quad (23)$$

Equation 23 overestimates evapotranspiration as determined from the grass lysimeters (and divided by 0.87) by 4% to 5% over the accumulated irrigation season. However, during the windy periods of May and June, Equation 23 can underestimate E_{tp} by about 10 to 15%. By solving for C_T and T_x and correlating with the lysimeter data, Equation 23 was slightly modified as indicated below:

$$E_{tp} = 4.75 \times 10^{-4} (T + 9.646) R_s \quad (24)$$

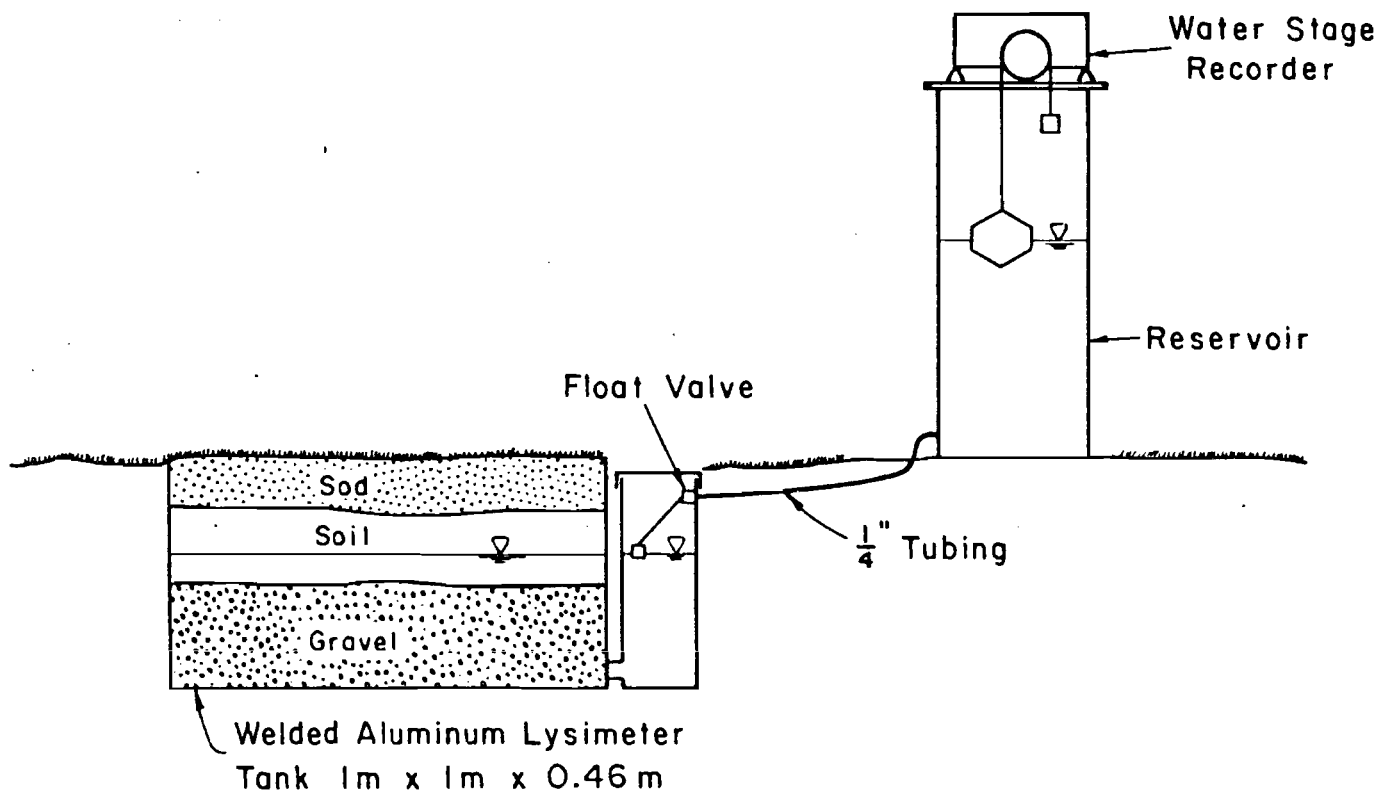

Figure 1. Constant water table lysimeter.

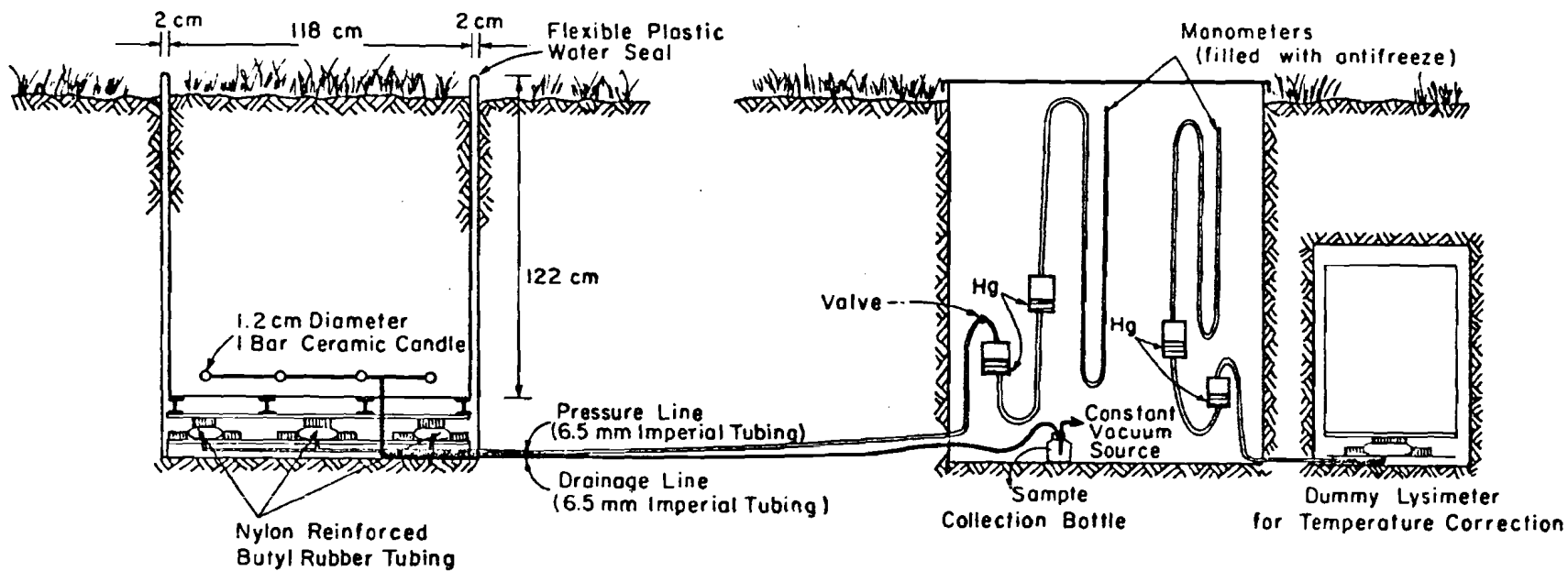

Figure 2. Hydraulic weighing lysimeter.

Penman Calculations

The Penman equation has several regression formulas implied in its form as listed in Equation 10. An evaluation of each of these was made, but the only effective correlation was between the wind term coefficients, a and b. Interestingly enough, the values determined for alfalfa (a = 0.90 and b = 0.0062) are not significantly different from the values Penman originally suggested for grass (Jensen, 1973). The resulting Penman formula for alfalfa (E_{tp}) is:

$$E_{tp} = 0.0171[C_1(R_n + G) + C_2(0.9 + 0.0062U_2)(e_2^o - e_z)] \quad (25)$$

Comparison of Methods

The mean monthly measured values of the grass lysimeter evapotranspiration for the Grand Valley are plotted against both the calibrated and original Blaney-Criddle relationships in Figure 4. These data were collected in 1975. The other years do not differ markedly, however. The revised function allows a substantially better monthly estimate of consumptive use than the version suggested by Blaney and Criddle (1950). In fact, over the season the measured and predicted (by the adjusted equation) are identical. The Blaney-Criddle approach is satisfactory for time periods greater than or equal to one month, but not the daily or weekly periods needed for irrigation scheduling. It is also obvious that application of the original Blaney-Criddle approach can lead to significant errors if the method is not locally calibrated.

Figure 4 shows the comparison of measured and calculated E_{tp} values during the 1975 irrigation season in Grand Valley when the Jensen-Haise method is applied. The error introduced by simply using the reported function with the altitude correction is too small to be significant, although about a 4 to 5 percent improvement was achieved in Figure 3. These lysimeters are irrigated for the purpose of maintaining a low-tension soil moisture condition. A neutron access tube or other methods are installed to assist in monitoring soil moisture distribution. A method of extracting the surplus water and to provide a leaching mechanism should be installed. One bar ceramic candles connected to a vacuum system work well for this purpose.

Calibrating Estimating Formulas

Once a reliable measurement of evapotranspiration is obtained, it is then used to calibrate the evapotranspiration estimating formulas for the

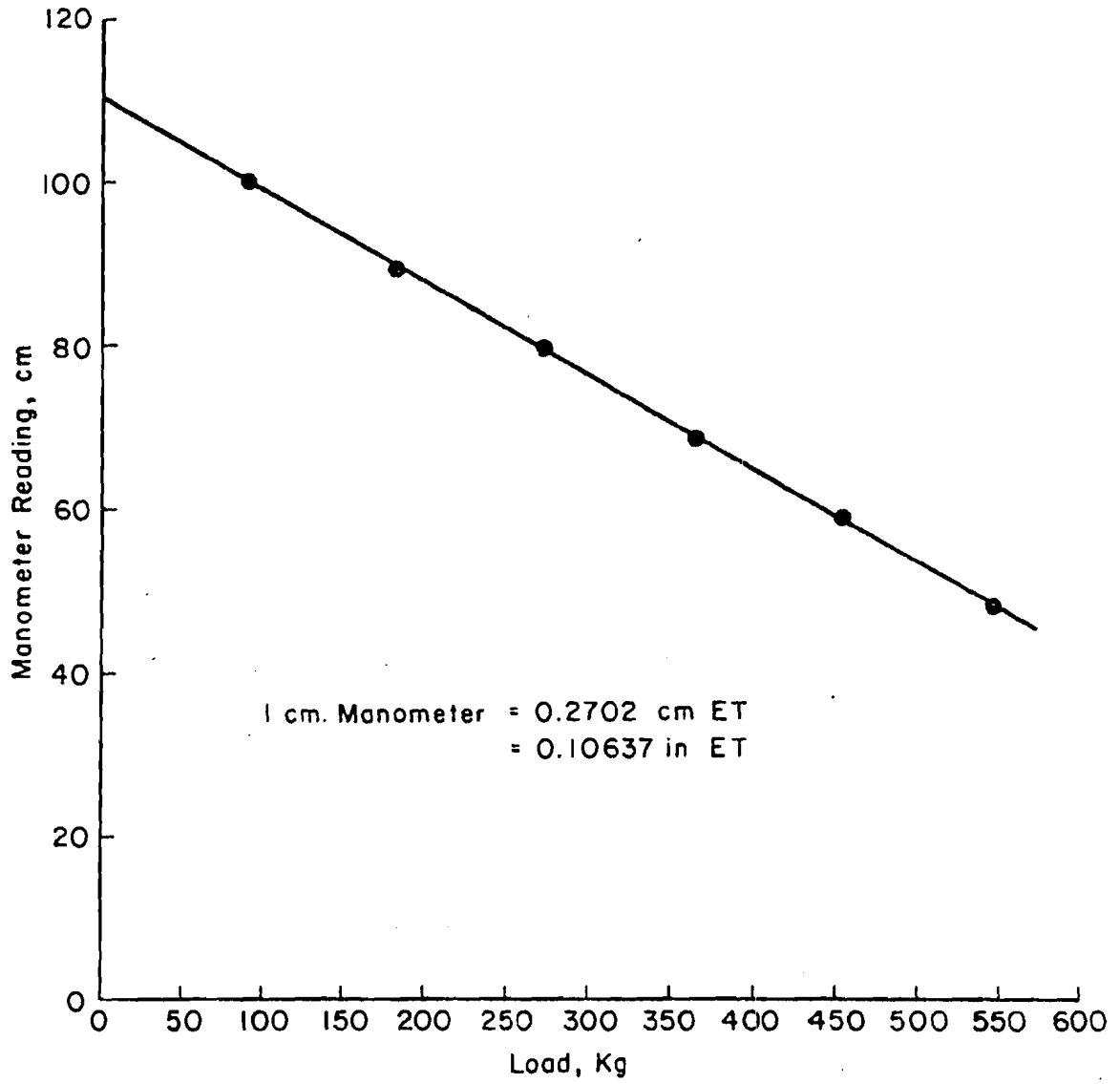

Figure 3.

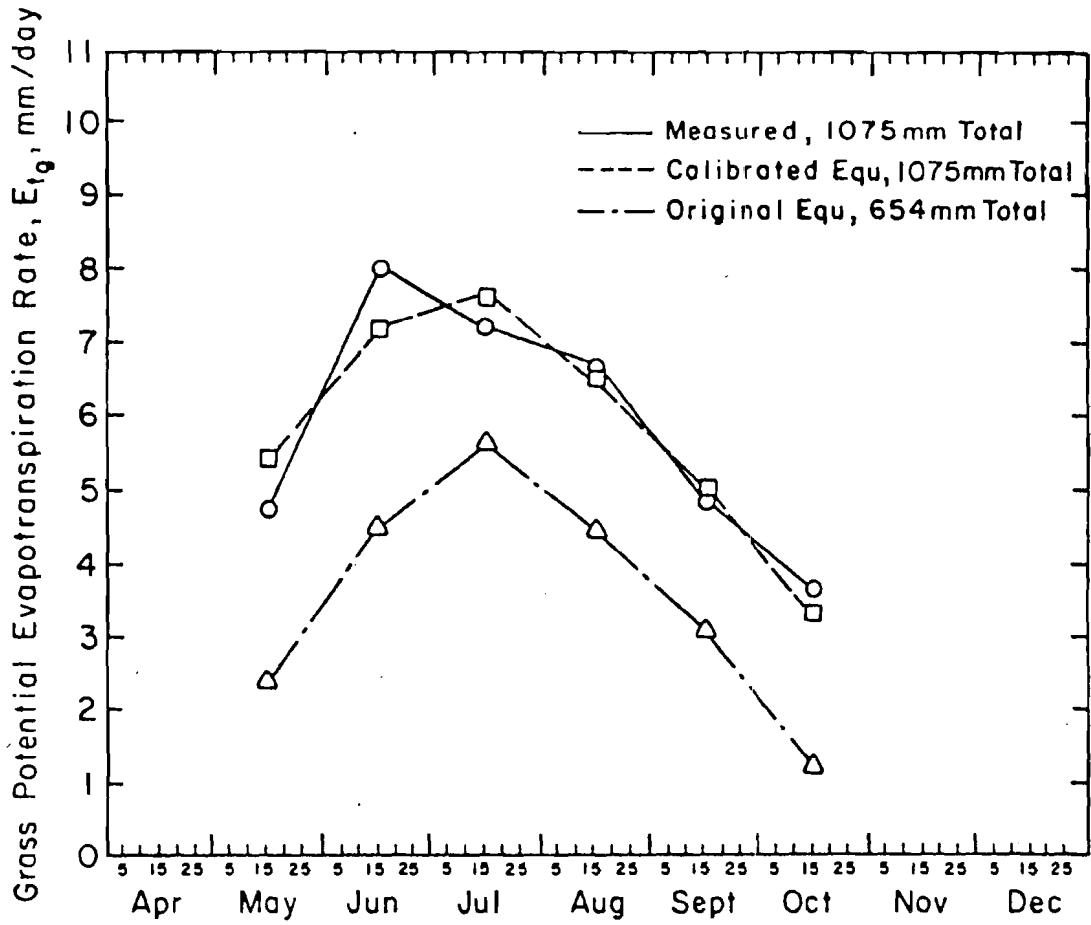

Figure 4. Comparison of lysimeter data with the Blaney-Criddle estimate for well-watered grass in 1975.

local conditions. For purposes of illustration, these formulas will be calibrated for conditions encountered in the Grand Valley of Colorado.

Blaney-Criddle Calibration

The uncalibrated Blaney-Criddle equation, as described earlier, underestimates E_{tp} in the Grand Valley by approximately 40 percent. Generally, in the windy months of spring the procedure underestimates E_{tp} by as much as 50%, whereas later results show substantial overestimation. The calibration of Equation 1 involved solving for the k_t term:

$$at - b = \frac{E_t \cdot 100}{p \cdot c \cdot k_t} \quad (21)$$

In this case, k_t was found to be:

$$k_t = -0.00268 + 1.49 \quad (22)$$

Even so, the month-to-month variations were large (i.e., Equations 1 and 22 overestimate E_{tp} in May, July and September, while it underestimates the values in June and August). It should be noted that calibration of the k_t parameter over so with local calibration. The Jensen-Haise method is often used in conjunction with the Penman equation in many irrigation scheduling services, primarily from July on when wind is less significant. The largest error in the time distributed estimates (5 to 6 day intervals) was less than 2 mm per day in the latter part of the Grand Valley's 1975 irrigation season. In June, a 5 mm error is noticeable.

Although the Penman equation shows more seasonal error than the Jensen-Haise approach (Figure 5), it follows the lysimeter data better over the season. In evaluating these results, it appears that time intervals less than 3 to 5 days are not justified by the sensitivity of the approaches. In fact, the correlation between measured and predicted values on a daily basis was less than 70 percent, whereas it was approximately 90 percent for 5 to 6 day periods.

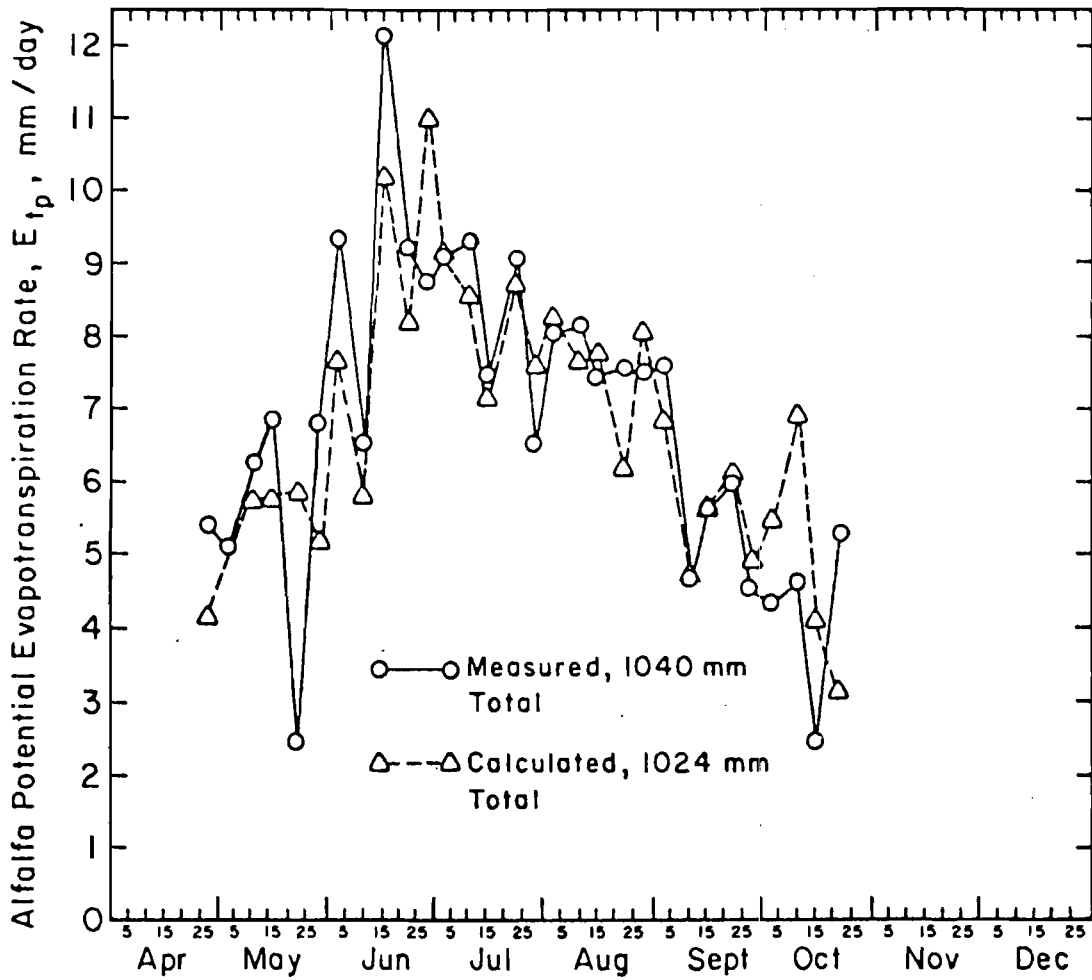

Figure 5. Comparison of lysimeter data and the Penman equation estimate for alfalfa in 1975.

EWUP

How to do it

Field Procedure



DIFFERENTIAL LEVELING FOR BENCH MARK SURVEY OF THE WATERCOURSE

by Wayne Clyma and Alan Early*

Differential leveling is the process of finding the differences in elevation of any two points. It usually requires several setups of the instrument along a general line between the two points. Each setup requires a rod reading on a point of unknown elevation. A bench mark survey is conducted to provide a widely spaced series of points (headgates, culverts, bridges, etc.) of known elevation from which a topographic survey is conducted at a later date.

THEORY OF LEVELING

Leveling is the process of determining the elevations of differences in elevations of points. Figure 1 illustrates the basic procedure.

A level is set up at a location approximately half-way between bench mark (B.M.) and a turning point (T.P.). A bench mark is relatively permanent, natural or artificial object bearing a marked point whose elevation is known or assumed. A turning point is a temporary bench mark for the purpose of continuing a line of levels. Portable turning points are provided for field watercourse surveys and topographic surveys.

For example, referring to Figure 1, if the elevation of the bench mark (B.M.₁) is assumed to have an elevation of 100.000 meters, the elevation of the turning point (T.P.₁) can be determined by leveling. First, the instrument is set up approximately half-way between B.M.₁ and T.P.₁ and is leveled. A rod reading is taken on B.M.₁ of 2.40. This rod reading is termed a backsight (B.S.). A backsight is a rod reading taken on a bench mark or turning point of known elevation. It is the vertical distance between the B.M. and the line of sight of the instrument. The line of sight

*This How-To-Do-It was taken from The Problem Identification Handbook (April 1, 1980). Developed by the CSU-Pakistan Water Management Project sponsored by U.S. Agency for International Development, Contract No. AID/TAC-1100.

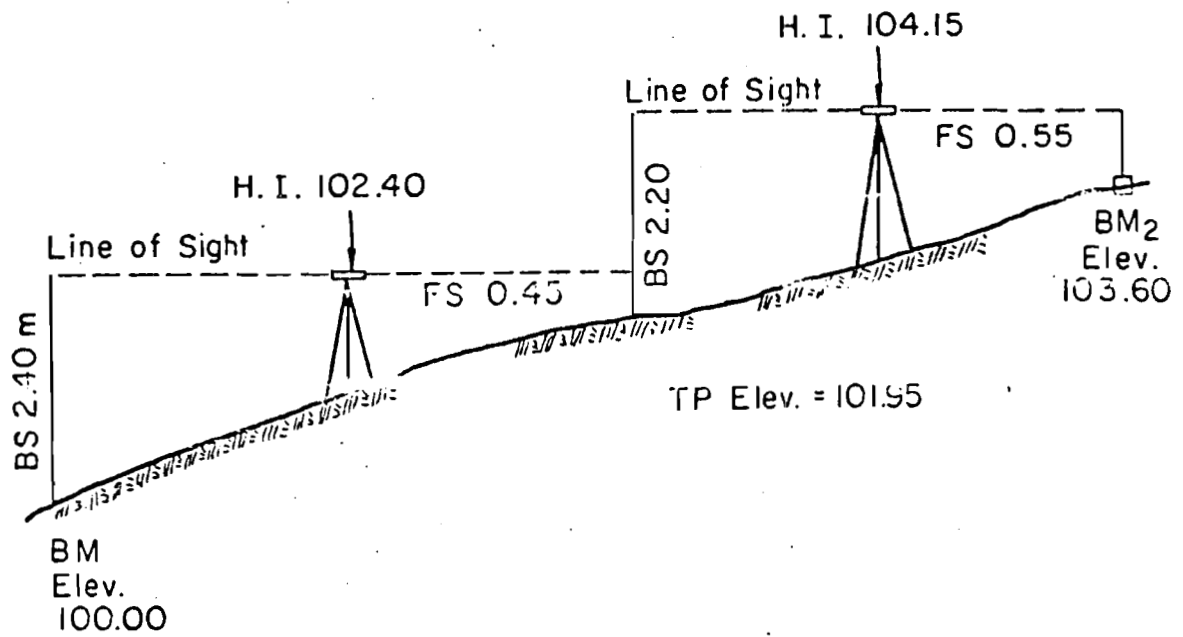

Figure 1. Theory of differential leveling.

of the instrument is almost always higher than the B.M. or the T.P. Therefore, the backsight is almost always positive and could be described as a plus sight.

The height of instrument (H.I.) is the elevation of the line of sight when the instrument is level. This corresponds to the line of sight of the instrument and is obtained by adding the backsight to the elevation of the B.M.₁, 100.00, to obtain the H.I., 102.40. Turning the telescope to bring into view the rod held on T.P.₁ a rod reading called a foresight is obtained. A foresight (F.S.) is a rod reading taken on a turning point of any other point of unknown elevation for which the elevation is to be determined. The foresight is almost always subtracted from the height of instrument and could be described as a minus sight. In the example of Figure 1, the F.S., 0.45, is subtracted from the H.I., 102.40, to obtain the elevation of T.P., 101.95. Thus, by a process known as leveling, we have determined the difference in elevation of two points. This methodology may now be used to check the elevations shown in Figure 1, and determine the elevation of T.P.₂.

From the above definitions, we can derive two equations that are quite beneficial in leveling. These equations will be repeated many times during a leveling exercise, so a person who is learning to use the level should become thoroughly familiar with them. They are:

$$\text{Elev.} + \text{B.S.} = \text{H.I.}$$

$$\text{H.I.} + \text{F.S.} = \text{Elev.}$$

Note that if a backsight is taken on a B.M. or T.P. located on the roof of a tunnel or the ceiling of a room with the instrument at a lower elevations, the backsight must be subtracted from the elevation to obtain the height of instrument. Also, if a rod reading is taken on a pipe or some other object higher than the instrument, the foresight must be added to the height of instrument to obtain the elevation.

PROCEDURE FOR DIFFERENTIAL LEVELING

Several procedures and precautions should be observed for accurate differential leveling. Refer to Figures 2 and 3 for sample rod readings and a sample set of notes for a differential leveling exercise.

To begin a differential survey, the rodman holds a rod on B.M.₁ while the levelman goes forward a convenient distance (not over 100 meters for a Bostrom-Brady farm level) and sets up the level. The levelman takes a

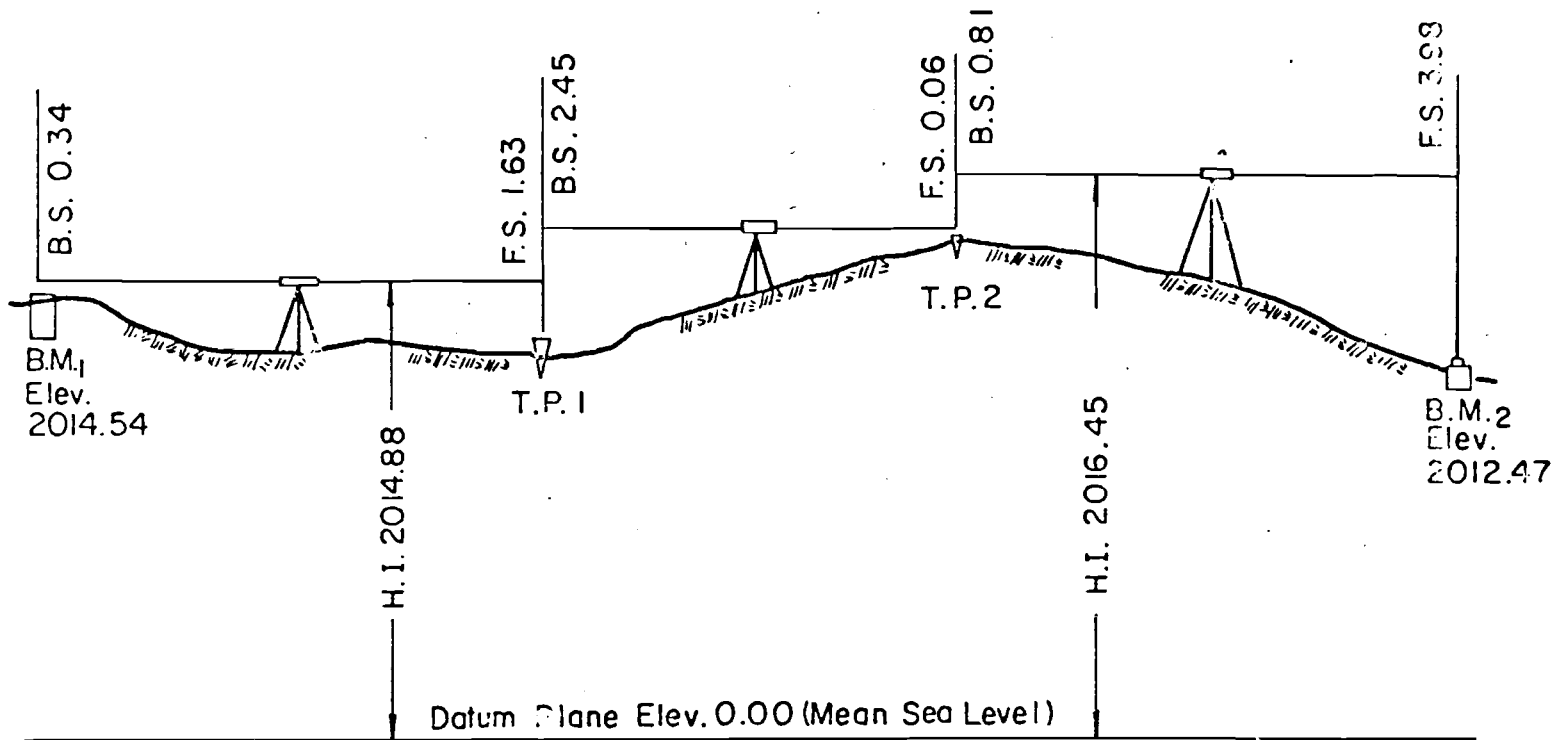

Figure 2. Illustrating the procedure for taking backsights and foresights of differential leveling.

57

DIFFERENTIAL LEVELING
FOR BENCH MARKS
Alemaya College Campus

Sunny, calm

Haily S. & N
Tewolde W.
Aug. 18, 1965

Sta	BS	HI	FS	Elev.	
BM ₁	0.34	100.34		100.00	B.M. ₁ : the southern bolt on the pole
TP ₁	2.45	101.16	1.63	98.71	nearest to the irrigation lab.
TP ₂	0.81	101.91	0.06	101.10	about 5 m from eastern side
BM ₂	3.98	101.91	3.98	97.93	door
TP ₃	0.00	101.19	0.81	101.10	
TP ₄	1.98	100.71	2.46	98.73	B.M. ₂ : Steel rod on the N.E. corner
BM ₁			0.69	100.02	of the cattle guard into the
BS =	9.65	FS =	9.63	0.02	livestock area across from
					poultry.

Error of closure =

$$9.65 - 9.63 = 0.02 \text{ check}$$

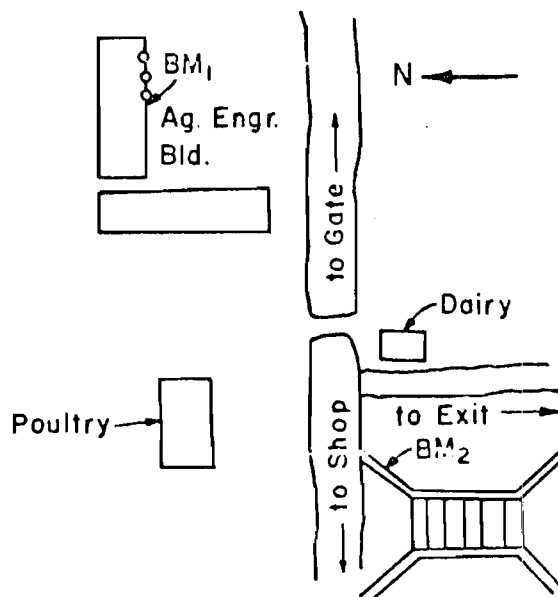

Figure 3. Sample differential leveling notes.

reading on the rod and determines where the middle cross hair strikes the rod, in Figure 2 at 0.34. This is a backsight and the notekeeper records 0.34 in the B.S. column of the notes. Now the H.I. is determined by adding the B.S. to the elevation of the B.M., ($100.00 + 0.34 = 100.34$), and is entered in the notes in the H.I. column. For the convenience of one who is learning this procedure, a plus sign can be placed above the B.S. column and a minus sign above the F.S. column to indicate how that column is used in note computations.

After the B.S. has been obtained, the rodman steps the distance from the B.M. to the instrument and then steps the same distance away from the instrument in the direction of B.M.₂. This pacing is one of the acceptable methods of balancing the horizontal distances between the backsight and the foresight. This distance can also be measured by stadia, but the accuracy obtained by taping is not considered necessary. The effects of refraction, curvature of the earth, and lack of instrument adjustment are thereby eliminated. On slopes a zigzag path may be taken to utilize the longer rod length available on the downhill sights.

CLOSED SURVEYS

To verify the accuracy of the leveling, a return check must always be made. That is, the line of levels must be continued from B.M.₂ back over a slightly different route to B.M.₁, the initial starting point. To make the return check independent of the first line of levels, after the F.S. is taken on B.M.₂, lift the level slightly and relevel it so that the H.I. will be at a slightly different elevation. This results in a B.S. on B.M.₂ different from the F.S. and should result in a better check of the line of levels. When the survey party has returned to B.M.₁, a closed survey has been completed. All leveling exercises should be closed surveys so that a check of the accuracy of the survey can be made. Figure 4 gives a sample traverse for a benchmark survey of a watercourse. Note that all available permanent structures are used as bench marks. These bench marks must be marked with both a waterproof marker and with a nail or screwdriver scratch for permanence. Figure 5 provides the sample survey notes for the traverse of Figure 4. Note the double tabling of points which are both turning points (T.P.) and bench marks (B.M.). Portable turning points are labeled PTP.

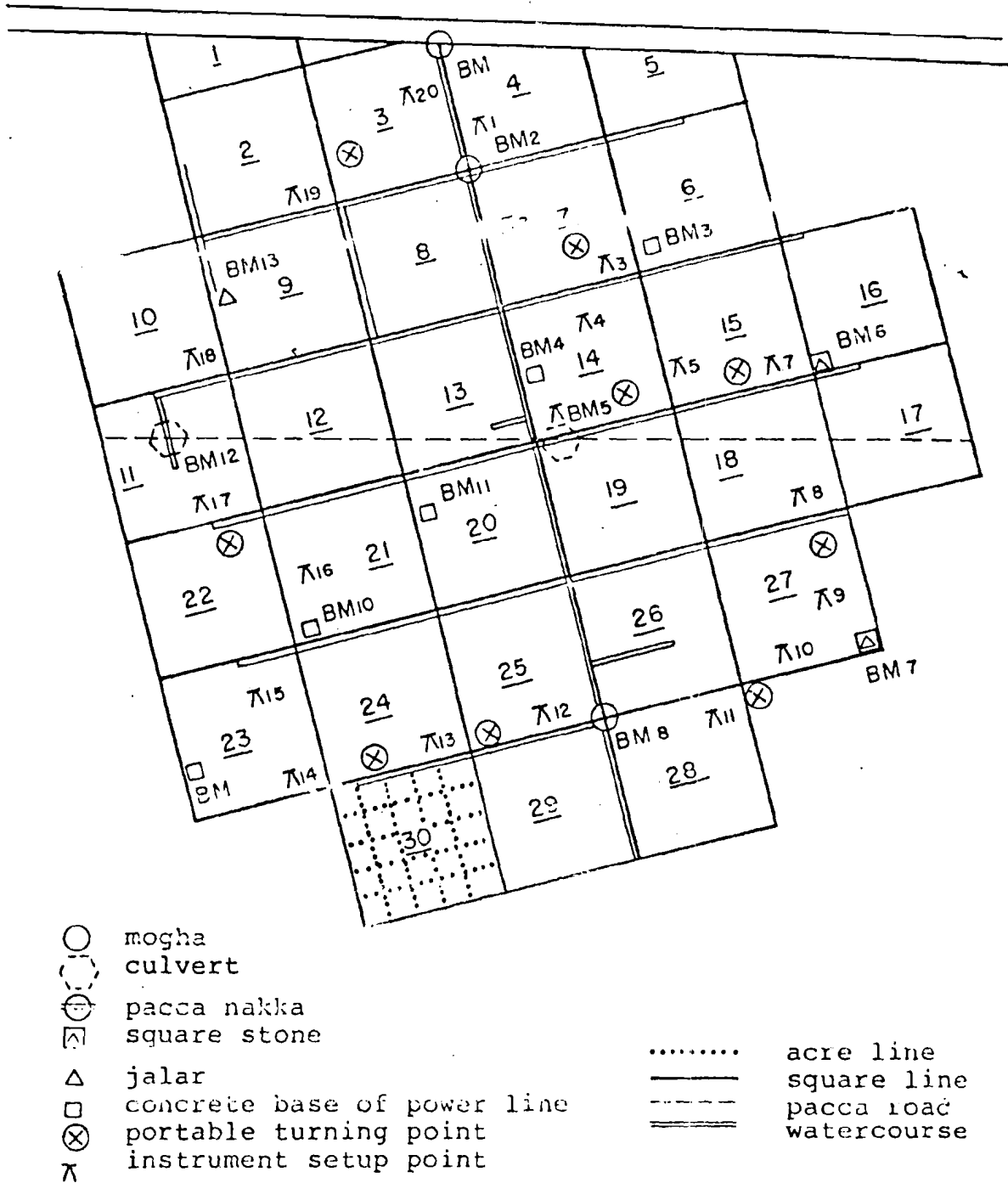

Figure 4. Sample traverse for bench mark survey of watercourse.

WATERCOURSE BENCH MARK SURVEY
BY DIFFERENTIAL LEVELING
Chak 110/JB, Lyallpur

Sunny Wanyam
Hot Zahid
Calm Aug. 18, 1975

Sta.	BS	HI	FS	Elev.		
	BM ₁	3.02	103.02	100.00	Mogha Scratch Mark - Upstream Side	
TP ₁	BM ₁	4.22	103.17	4.07	98.95	Pacca Kanna Corner of Squares
TP ₂	TP ₂	3.89	102.05	5.01	98.16	3, 4, 7 and 8
TP ₃	BM ₂	6.87	104.85	4.07	97.98	Sq. 6: CBPL* - Scratch
TP ₄	BM ₃	4.48	102.44	6.89	97.96	Sq. 14: CBPL - Scratch
TP ₅	BM ₄	4.32	101.75	5.01	97.43	Sq. 13, 14: Concrete culvert -
TP ₆	TP ₅	5.10	101.60	5.25	96.50	upstream
TP ₇	TP ₆	4.88	101.50	4.98	96.62	
TP ₈	BM ₇	3.37	99.61	5.26	96.24	Sq. 15, 16, 17, 18: Square stone -
TP ₉	TP ₆	3.85	99.28	4.18	95.43	scratch
TP ₉	BM ₉	4.71	99.98	4.01	95.27	Sq. 25, 26, 28, 29: Square stone -
TP ₁₀	TP ₇	4.85	99.56	5.27	94.71	scratch
TP ₁₁	BM ₁₁	5.17	99.44	5.29	94.27	Pacca Nakka Corner of Squares 25,
TP ₁₂	TP ₈	4.37	98.81	5.00	94.44	26, 28, 29
TP ₁₃	TP ₁₃	3.99	98.28	4.52	94.29	
TP ₁₄	BM ₁₄	4.00	98.37	3.91	94.37	Sq. 23: CBPL - scratch
TP ₁₅	BM ₉	6.02	100.77	3.62	94.75	Sq. 21: CBPL - scratch
TP ₁₆	BM ₁₀			/5.91/	94.86	Sq. 20: CBPL - scratch
TP ₁₇	TP ₁₁	6.27	101.77	5.27	95.50	
TP ₁₈	BM ₁₇	5.33	102.82	4.28	97.49	Sq. 11: Concrete Culvert: Scratch -
TP ₁₉	BM ₁₂	4.81	103.74	3.89	98.93	Downstream
TP ₂₀	TP ₁₃	4.68	104.72	3.80	99.94	Sq. 9: Steel frame on Jalar Base -
	BM ₁			4.51	100.11	scratch
						Mogha
BS =	98.20	FS =	98.09	0.11	= Elev. Diff.	

Error of closure = 98.20 - 98.09 = 0.11

*Concrete Base of Power Line - CBPL

Figure 5. Watercourse benchmark survey notes by differential leveling.

ERROR OF CLOSURE

If there have been no errors made in a closed survey or if the errors have compensated, then the elevation determined for B.M.₁ by the return check will be the same as the original elevation of B.M.₁. Generally these elevations are not exactly the same due to errors in rod readings or instrumental errors. The amount by which the original B.M. elevation and the B.M. elevation observed upon the return check fail to agree is called the error of closure.

Allowable errors of closure for a survey is a function of the accuracy of the instrument and the length of the survey or the number of times the instrument is set up. For a Bostrom-Brady level, the allowable error of closure equals 0.01 meters per two instrument setups (0.01/2 setups). For the notes shown in Figure 3, there were four instrument setups so the allowable error of closure was 0.02. The actual error for the survey. For general leveling purposes with available equipment, the allowable error in English units (feet) is given by:

$$\text{Allowable error} = 0.000 \sqrt{\frac{\text{length of traverse in feet}}{100}}$$

If the sample traverse for Figure 4 were 20,000 ft., then the allowable error is 0.0989 or 0.10 foot. Bench mark surveys which do not meet this standard must be completely resurveyed until the error of closure is less than the allowable error. The survey whose notes are provided in Figure 5 does not meet the standard and must be repeated.

CHECKING THE LEVEL NOTES

The computations of the level notes should always be checked by comparing the difference between the sum of the backsights (B.S.) and the sum of the foresights (F.S.) with the differences between the initial and final elevation of the B.M. and used to close the survey before leaving the field. This computation checks the notes for errors in arithmetic. The two differences must agree or an error in arithmetic has been made. No set of leveling notes is complete without an error of closure computation and check of the arithmetical accuracy of the notes, before leaving the field.

USE OF THE BENCH MARK SURVEY

The bench mark survey when completed to the required standard of accuracy becomes a basic for additional field surveys that are completed subsequently. The permanent benchmarks can then become starting points for

any portion of the profile leveling survey of the watercourse and of the topographic survey of the watercourse. This set of benchmarks is then a set of known elevations to facilitate the completion of these other surveys.

PORTABLE TURNING POINTS

While profile leveling, benchmark or topographic surveying, the need for intermediate turning points arises frequently. The placement of the staff rod on the ground or on the bed of the watercourse can lead to errors of major magnitude, if when the rod is rotated in contact with the soil, changes in rod elevation occur. To avoid this problem and source of inaccuracy, portable, stable turning points are provided for field use. Figure 6 shows this simple surveying item. It is nothing more than a 4 inch square piece of #14 or #16 sheet metal with one-inch corners bent down at 90° from the face to form four legs. A rivet in the center holds a chain handle to the bottom side. The rod is rotated on the rivet after the turning point has been forced into the ground.

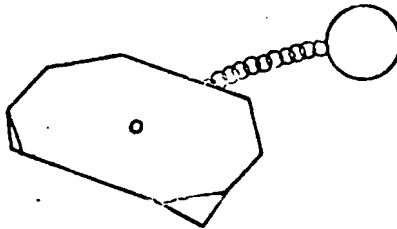

Figure 6. Portable pucca turning point.

EWUP

How to do it

Field Procedure



PROFILE LEVELING OF MAIN AND LATERAL CONVEYANCE CHANNELS

by Wayne Clyma and Alan Early*

GENERAL

Profile leveling is the process of determining the elevation of the ground surface at a series of points at measured intervals along a drainage ditch, terrace, waterway, road, or for any other purpose where it is necessary to consider changes in elevation of the ground surface.

TAPING PROFILES

It is necessary to tape or otherwise measure the horizontal distances for a profile. Vertical distances along the profile would have no meaning without the corresponding horizontal distances between changes in elevation.

Stakes or chaining pins are usually set along the fixed line for a profile survey. These stakes or chaining pins are usually set before the survey is made. Stakes are placed at fixed distances along a survey i.e., 25', 50', or 100', depending upon the detail required for the survey. In addition, stakes are set at points where the line changes direction and at every full station. For the profile survey of the watercourse main and the major branches, chaining pins should be used to mark the stations at 25' distance intervals.

A full station is 0 + 00, 1 + 00, 2 + 00, etc. Stakes set at any other point between the full stations are called plus stations and are designated, for example 1 + 25. Note that 0 + 00 designates the beginning of the line. Distances along the line indicate the full stations and the plus stations for instance 150 ft is written as 1 + 50 ft. Thus, the digits to the left of the + designate the distance in multiples of 100', while those to the right indicate less than 100'. The station number is usually marked upon

* This How-To-Do-It was taken from The Problem Identification Handbook (April 1, 1980). Developed by the CSU-Pakistan Water Management Project sponsored by U.S. Agency for International Development, Contract No. AID/TAC-1100.

that side of the stake facing 0 + 00. Stakes are arranged, when possible, so that the wide part of the 2" x 5" stake points to the next station on the line.

A stake is driven at each station located on the profile. Each station will also be entered in the field notes. Pins will no longer be necessary to count tape lengths, since the length of the line will be recorded in the notes. For other than 100 ft tapes, two pins may be used to measure full tape lengths. When other than full tape length is measured, the rear chainman holds the partial tape length at the appropriate point. The stake is located for that station. The note keeper adds the partial tape length to his last station and records the new station. Since the head chainman has the zero end of the tape, the intermediate distances are read directly on the tape without subtraction.

Intermediate Sights

The purpose of the profile survey is to determine the true slope of the ground surface or watercourse bed surface. This means that where there is an obvious change in the slope of the ground or bed surface, a stake is placed and an intermediate sight (foresight or minus sight) is taken so that the elevation of the ground surface at that point can be determined. The foresights for a profile are called intermediate sights because they are foresights intermediate or between the foresights taken on T.P.'s for a continuing line of levels. The student beginning profiles has a tendency to take more intermediate rod readings than are necessary. The guide to remember so that none are left out is to take an intermediate shot wherever the ground surface changes slope. If in doubt, take the rod reading. It is simpler to have an extra rod reading than to leave out one that was necessary.

Procedure for Profile Leveling

The first step in profile leveling is to establish the centerline of the watercourse, terrace outlet channel, or road to be profiled and to measure the line accurately setting stakes at all points where rod readings are to be taken. Set the level up near the line to be profiled. It is normal to offset the instrument from the line so that more nearly equal horizontal distances from the instrument to the rod can be obtained. A rod reading is obtained on the bench mark and the height of instrument is determined. Frequently the bench mark is located so that more than one

instrument setup is required before the rod can be read at the stakes located on the profile line. When this is necessary, the T.P.'s are selected and the notes are as for a differential survey. Rod readings are observed on the ground or bed with portable pucca turning point adjacent to the stake of chaining pin for the intermediate shots. For turning points, all rod readings are taken on top of a stake if the stake is used or on the portable pucca turning point if chaining pins are used. When placing the rod adjacent to a stake for an intermediate shot, the student should always try to select average ground. That is, the rod should not be placed in a hole, nor should it be placed on the top of a hill or clod. The location should represent the average of the ground surface immediately around the stake.

For an example of a ground surface profile and corresponding rod readings, see Figures 1 and 2. After the instrument has been leveled, a rod reading is obtained on the B.M. and the H.I. is computed. In the example, a B.S. of 1.02 gives an H.I. of 101.02, a rod reading is then obtained near 0 + 00 for the first shot, 0 + 38.03 for the second shot, and so forth until station 0 + 72.56 has been read. A turning point is then necessary, so a T.P. is selected and a foresight of 1.60 is obtained on the top of the stake. The instrument is carried to a new position along the line, releveled, a B.S. of 0.98 obtained on T.P., and a new H.I. computed. We are now ready to take additional intermediate shots along the profile line. This process is continued until the profile is completed. A complete set of profile leveling notes is shown in Figure 3.

Closed Surveys

In profile leveling, as in differential leveling, a closed circuit of levels must be made to check the accuracy of the survey. This is done, as in differential leveling by running a line of differential levels back to the bench mark from which the survey was begun.

Error of Closure and Checking the Notes

The method of checking the note computations and computing the error of closure is shown in Figure 4. Note that for a profile survey the foresight and the backsights used for computing the error of closure are only those which were taken on the B.M.'s and T.P.'s. The intermediate rod readings are not used in the computation for error of closure. The only method of checking the intermediate rod readings is to rerun the entire profile.

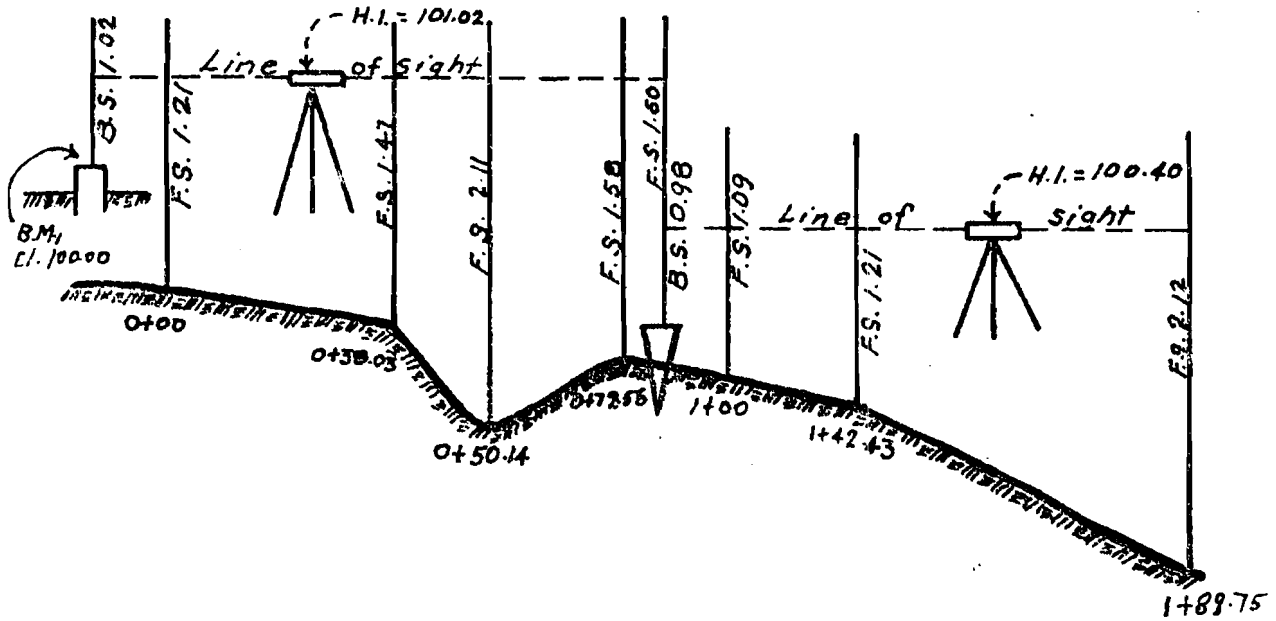

Figure 1. Rod readings for profile leveling.

PROFILE LEVELING

Sta.	ES	EI	ES	Elev.
BM ₁	1.02	101.02		100.00
0 + 00			1.21	99.81
0 + 38.03			1.47	99.55
0 + 50.14			2.11	98.91
0 + 72.56			1.50	99.44
TP ₁	0.98	109.40	1.69	99.31
1 + 80			1.09	99.31
1 + 42.43			1.21	99.19
1 + 89.75			2.12	98.28

Figure 2. Left side of notes for profile shown in Figure 1.

PROFILE FOR AG. ENGR. CULVERT

Sta.	BS	HI	FS	Elev.
BM ₁	1.62	101.62		100.00
0+00			0.51	101.11
0+4.12			0.86	100.76
0+8.75			1.14	100.48
0+12.50			1.39	100.23
0+15.96			0.92	100.70
0+20.58			1.65	99.97
0+27.85			1.98	99.64
0+30.00			2.16	99.46
0+36.90			2.39	99.23
0+39.42			2.25	99.37
0+42.30			2.76	98.86
TP ₁	0.23	99.70	2.15	99.47
0+48.4			1.26	98.44
0+58.56			1.91	97.79
0+60.00			1.95	97.75
0+65.83			1.93	97.77
0+69.90			3.05	96.65
0+72.18			3.44	96.26
0+72.65			3.60	96.10
0+73.19			3.48	96.22
0+76.49			3.30	96.40
0+81.55			3.50	96.20
TP ₂	0.54	96.93	3.31	96.39
0+83.15		96.93	1.27	95.66
0+85.30			1.49	95.44
0+88.10			1.56	95.37
0+90.00			1.83	95.10
0+93.40			1.90	95.03
0+97.31			2.21	94.72
TP ₃	3.32	99.70	0.55	96.38
TP ₄	1.72	100.93	0.49	99.21
BM ₁			0.92	100.01
Σ BS =	7.43	Σ FS =	7.42	100.00
Error of closure =	Σ BS - Σ FS			
	= 7.43 - 7.42			
	= 0.01			0.01 check

Tewolde W.R&N
Mehary T. ϕ

Cloudy, shower
Oct. 7, 1965
BM: an x mark on the
retention wall at the
north side of the
Agri. Engr. building,
about 2.60 m above
the first step, under
a lamp post.

Figure 3. Sample notes for a profile leveling exercise.

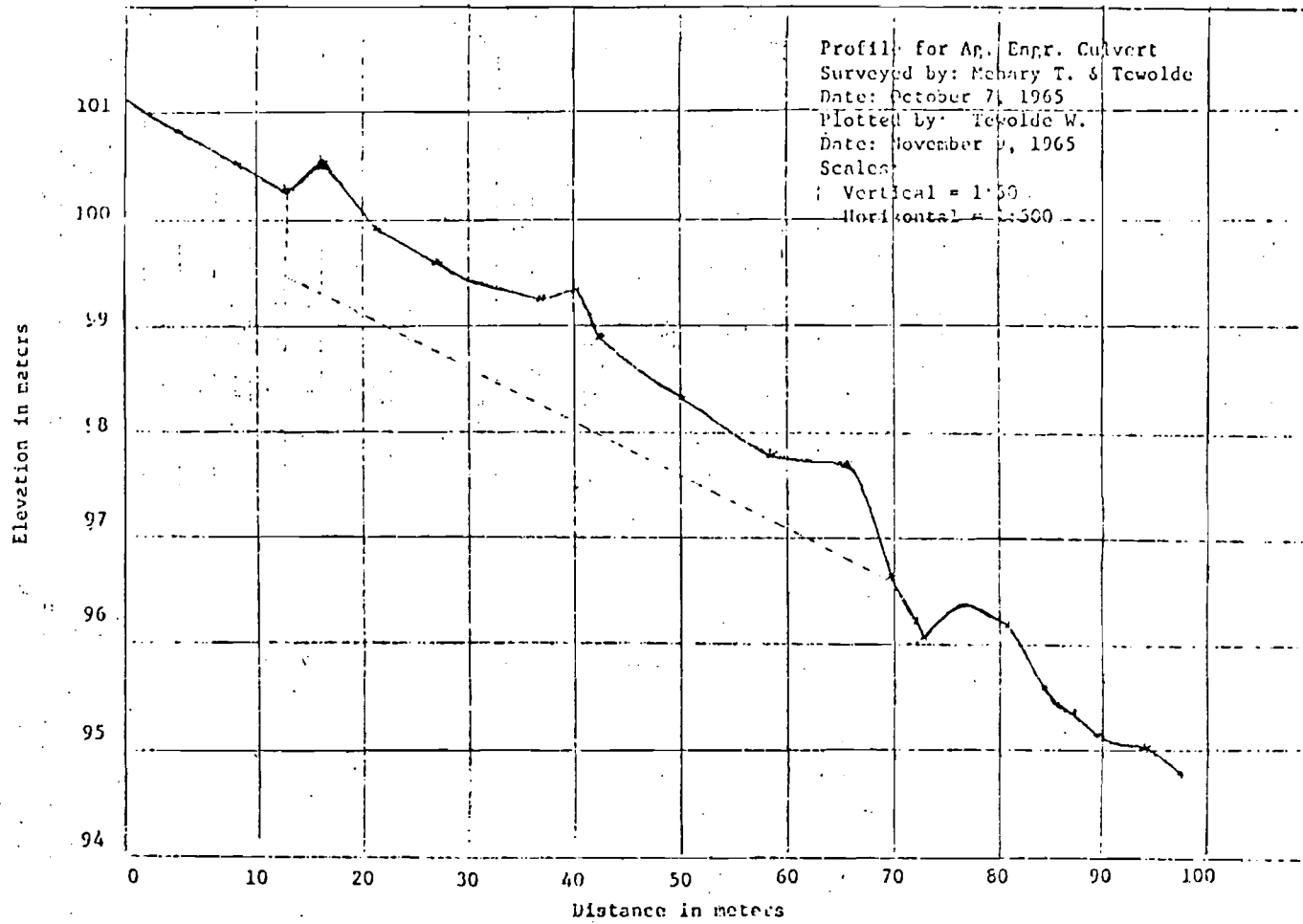

Figure 4. Cross section plot for a profile leveling exercise.

BEST AVAILABLE COPY

Plotting Profiles

Profiles are usually plotted on paper and the result called a cross section. Special profile paper can be obtained which simplifies plotting, but any ruled paper may be used.

The vertical scale of a profile is generally exaggerated with respect to the horizontal scale in order to make differences in elevation more pronounced. This is because the vertical distances in elevation are usually much less than the horizontal distance covered by the profile. The exaggeration is usually on a ratio of 10/1. That is, for a horizontal scale of 1:500, (i.e., 1 foot equals 500 ft) the vertical scale would be 1:50 (1 foot equals 50 ft). Since the points plotted on the paper from the profile represent "average ground" it is usually the practice to draw smooth lines (not straight lines) from point to point.

The plotted profile is used for many purposes, such as:

1. Determination of the depth of cut for a drainage or irrigation watercourse.
2. Determination of the fill for a farm pond.
3. Selection of the grades for a drainage ditch, irrigation watercourse or culvert.

Rate of grade, gradient, or just grade is the rise or fall in feet per 100 feet. Thus, a grade of 2.5 means that there is 2.5 ft difference in the elevation per 100 feet horizontally. Ascending grades are plus and descending grades are minus. The selection of a grade line for a project involves the principles of engineering design.

The term "grade" is also employed to denote the elevation of the finished surface of an engineering project.

EWUP

How to do it

Field Procedure



VEGETATIVE LAND USE MAPPING

by M. B. Lowdermilk and A. Early*

INTRODUCTION

The inventory of land and water resources in an area is important for any hydrologic study. Significant agricultural land use surveys have been conducted by the U.S. Department of Interior, Bureau of Reclamation, and the U.S. Department of Agriculture, Soil Conservation Service for many irrigated areas in the United States. In addition, detailed soil survey information has been developed for almost all irrigated areas.

The quantity of water transpired by vegetation, and evaporative losses from various water surfaces account not only for the most significant phase of the hydrologic or water flow system, but also play an important role in the salt flow system. An understanding of water and salt budgets can be obtained only by careful study of the water and salt flow systems in the area utilizing recognized hydrologic techniques. This is usually done by extensively studying a small area and extending the results to the entire irrigated area. A budgeting process must be designed to account for the water as it moves about and changes use within the area, and it must also be designed to account for the salt and its relative flow system. Consequently, once such budgets have been prepared which define the system, it then becomes possible to test or delineate the effects of various changes or proposed water management alternatives upon the system. In order to extend the analysis to an area-wide basis, it is important that the land use be determined for the entire area.

The type of land use data required for the preparation of a budget consists of delineating the various types of vegetation and land uses utilizing water in excess of normal precipitation. This cataloging process

* This How-To-Do-It was taken from The Problem Identification Handbook (April 1, 1980). Developed by the CSU-Pakistan Water Management Project sponsored by U.S. Agency for International Development, Contract No. AID/TAC-1100.

is an expensive and time consuming effort which includes separating the agricultural areas from the wetland phreatophytes, the urban areas and the industrial areas as well as the open water surfaces. These types of studies are not only necessary for budgeting procedures, but they also provide an excellent data base for future studies in an area for many disciplines. This data must be collected by field investigations.

Aerial photographs are an excellent tool to be used in vegetative land use mapping. The most current photographs available should be used since land use changes are usually minimal, field boundaries have not changed, ditches have not been relocated, farmsteads and urban areas are easily defined, and adjustments and updating are easily accomplished.

Aerial photographs having almost any scale can be ordered from the U.S. Department of Agriculture, Agricultural Stabilization and Conservation Service, Aerial Photography Division, Western Laboratory in Salt Lake City, Utah. It is important to select a scale for the photographs which corresponds to other base maps or design maps which exist or will be used for the project.

The range, township, and section numbers are marked on the photographs which are then taken into the field and the land use at the time is marked on the appropriate photographs for each field. A suggested land use mapping index is presented in Table 1. Other indexes are in use by the USBR, SCS, and other agencies, but whatever index is used for mapping purposes, it should be compatible with other studies which have been undertaken in the area or river basin. A typical photograph from which the land uses were labeled in accordance with the water related land use index is shown in Figure 1. For example, a field marked A1 on the aerial photograph indicates that during that year, corn was grown in that field. Although it is realized that certain changes will occur from year to year, it is usually safe to assume that the total acreages and the distribution of crop acreages varies slowly with time over a large area.

Due to the scale distortion, which is always present in aerial photographs, an effort should be made to prepare land use base maps with accurately placed section lines. To assist in accomplishing this, maps should be prepared using a grid based on geodetic coordinates. This is usually not a problem since most agricultural areas in the western United States have roads and field boundaries corresponding to these coordinates.

Table 1. Suggested land use mapping index.

-
- A. Irrigated Cropland
 - 1. Corn
 - 2. Sugar beets
 - 3. Potatoes
 - 4. Peas
 - 5. Tomatoes
 - 6. Truck crop
 - 7. Barley
 - 8. Oats
 - 9. Wheat
 - 10. Alfalfa
 - 11. Native grass hay
 - 12. Cultivated grass and hay
 - 13. Pasture
 - 14. Wetland pasture
 - 15. Native grass pasture
 - 16. Orchard
 - 17. Idle
 - 18. Other
 - B. Dry Cropland
 - 1. Alfalfa
 - 2. Wheat
 - 3. Barley
 - 4. Beans
 - 5. Cultivated grasses
 - 6. Fallow
 - 7. Other
 - C. Other Land Use
 - 1. Farmlands
 - 2. Residential yards
 - 3. Urban
 - 4. Stock yards
 - 5. School yards
 - D. Industrial
 - 1. Power plants
 - 2. Refineries
 - 3. Meat packing
 - 4. Other
 - E. Open Water Surfaces
 - 1. Major storage
 - 2. Holding storage
 - 3. Sump ponds
 - 4. Natural ponds
 - F. Phreatophytes
 - 1. Cottonwood
 - 2. Salt Cedar
 - 3. Willows
 - 4. Rushes or cattails
 - 5. Greasewood
 - 6. Sagebrush and/or rabbitbrush
 - 7. Wildrose, squawberry, etc.
 - 8. Grasses and/or sedges
 - 9. Atriflex
 - P. Precipitation only

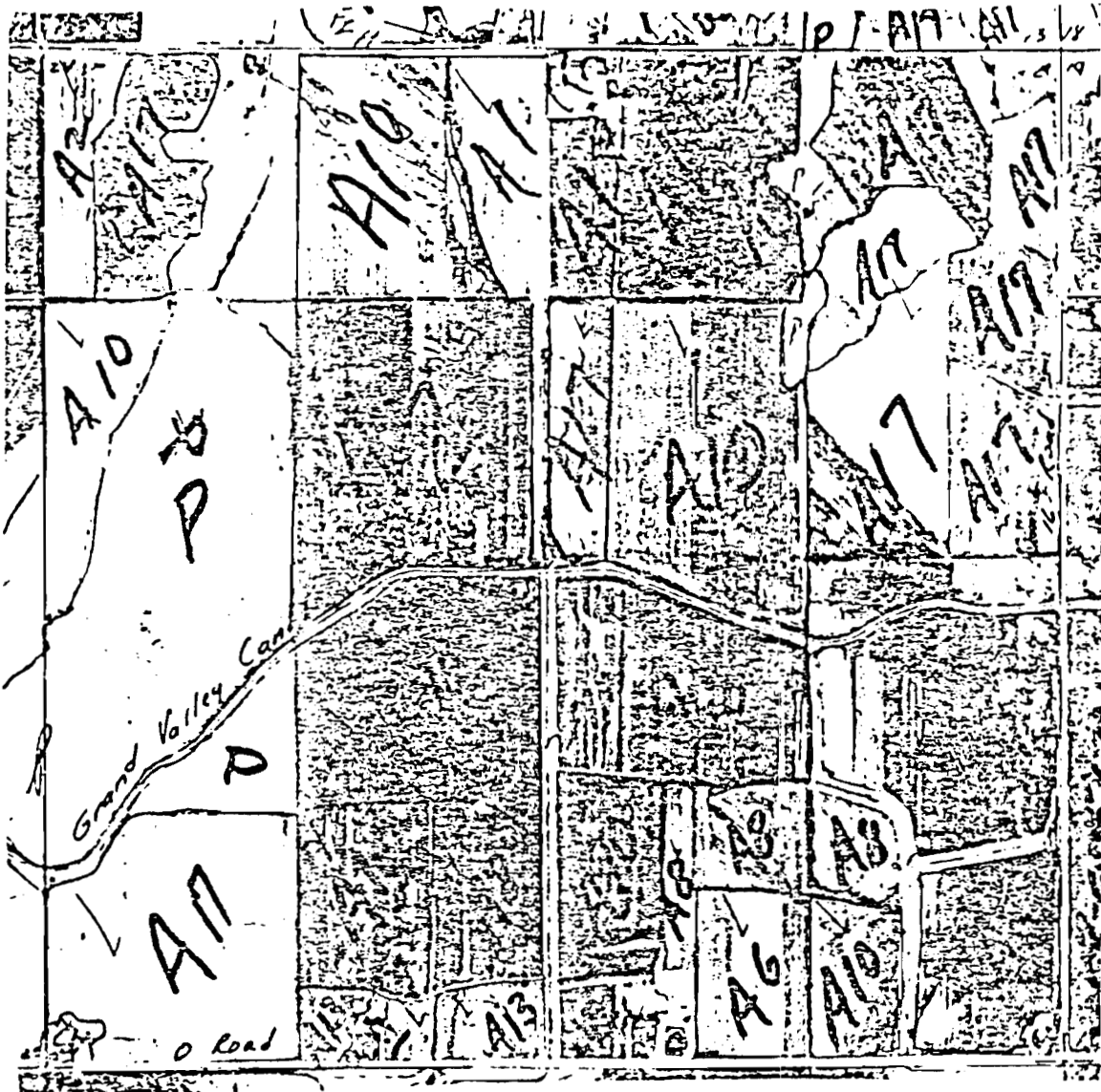

Figure 1. Typical areal photograph used for land use mapping showing the land use mapping index used in Table 9.

The scale of the base maps should correspond directly to the scale of the aerial photographs. U.S. Geological Survey quadrangle maps can be used for control where available. In addition, there are several computer techniques available to correct for distortion if adequate control is established.

The various water related land use areas are then transferred from the aerial photographs to the base maps which also depict the individual field boundaries (see Figure 2). The irrigation conveyance system should be added to the base maps in order that lands served by each canal or lateral could be established if desired.

In addition, many sections are not exactly 640 acres (259 ha), and they can often vary by as much as ± 10 percent of this value. It is therefore necessary to establish the area of each section. One method is to use graphical computer techniques or planimeter each section from the quadrangles to arrive at the correct acreage for that section. The acreage of each land use within that section must also be determined from the base maps by similar methods. The acreage of each and use is then summed for each canal, each lateral, or each watershed to arrive at the needed values.

The results of these investigations, including the base maps and/or tabulation of the data for each section or subgroup, should be organized and made available for public distribution. This type of information is very valuable and is needed by many state and local planning agencies, public interest groups, environmental impact assessments, etc. In addition, this information provides a very good basis for comparison in future land use related investigations. Examples of these types of publications are Walker and Skogerboe (1971) and Evans et al. (1973).

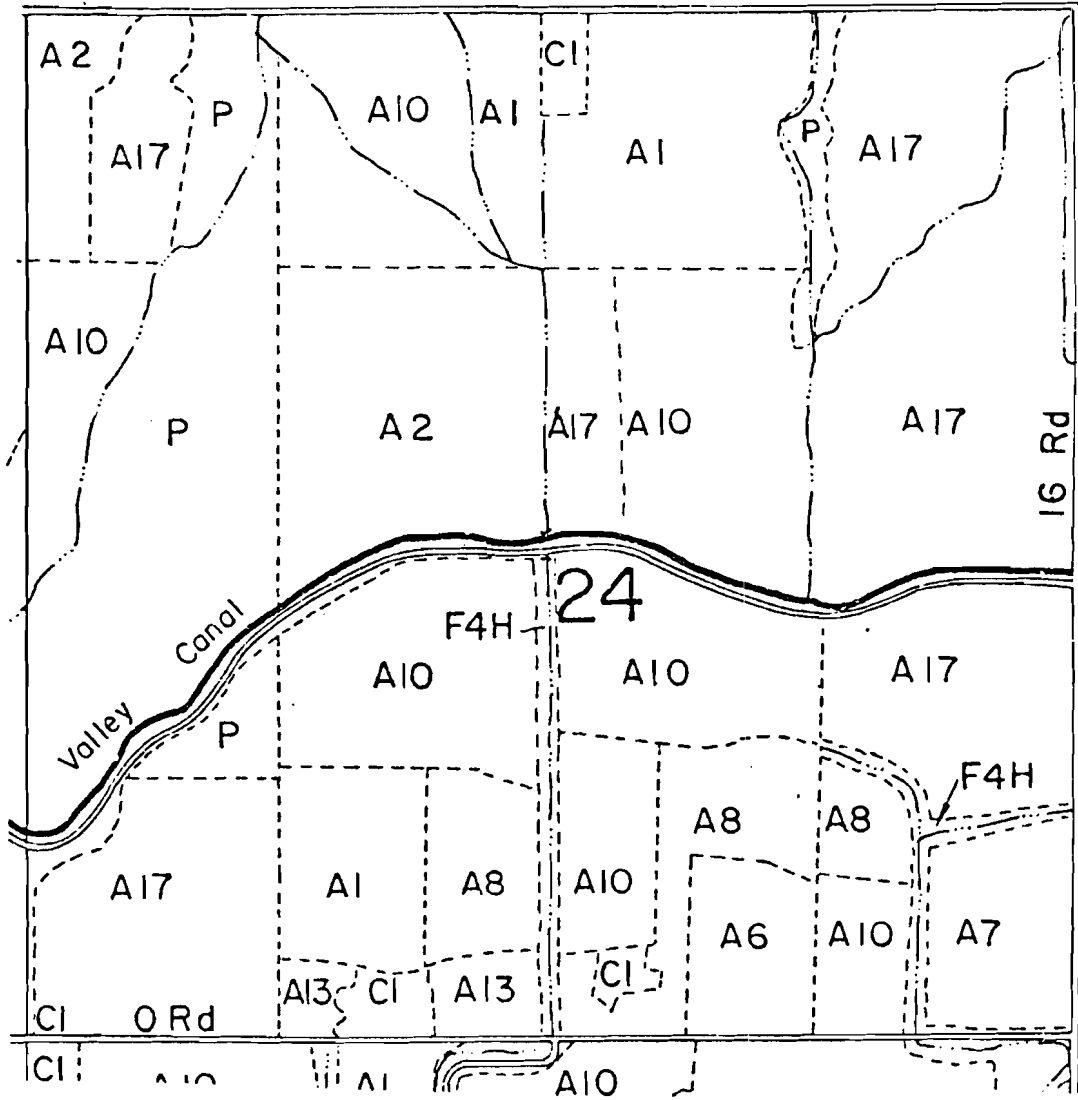

Figure 2. Finished map corresponding to the areal photograph shown in Figure 1.

EWUP

How to do it

Field Procedure



SOIL MOISTURE DETERMINATION TECHNIQUES

by Alan Early*

Water management proficiency requires that the technician learn the water requirements of the plants to be grown and how much of that water can be furnished from soil stored moisture and how much and how often it must be applied through irrigation. Soil moisture determination, therefore, becomes important as soon as soil samples have been collected and prepared.

First, the sample must be protected against moisture loss from the time of collection until the initial weight has been recorded. Airtight metal or plastic containers are used for this purpose. Two types of moisture determination methods are used. The gravimetric (measurement by weight) determination involves the determination of weight differences at the time the sample is collected and after it has been dried to measure the amount of the water contained in the soil. The touch and feel (TAF) method is a field procedure which is utilized to make quick, practical estimates of moisture resources and requirements.

GRAVIMETRIC DETERMINATIONS

The Oven

The oven is the tool utilized by the laboratory to determine soil moisture analyses. It provides an exact analytical measurement of the amount of moisture contained in the soil, and through the combination of the results from samples representing various segments of the soil profile, the water content of the field within the root zone of the crop to be produced can be calculated. The exact requirements of the research scientist are provided for by this method.

Standard procedures in the use of the oven are:

- a. Weigh and record the weights of the airtight containers and the soil they contain.

*This How-To-Do-It was taken from The Problem Identification Handbook (April 1, 1980). Developed by the CSU-Pakistan Water Management Project sponsored by U.S. Agency for International Development, Contract No. AID/TAC-1100.

- b. Open the containers and place in the oven which has been set at 105°C.
- c. Dry for 24 hours.
- d. Record the dry weight.
- e. Subtract dry weight from the weight of the field-collected sample. The difference is water.

This procedure may be repeated as necessary until the weight becomes constant, since some soils dry more readily than others.

The Sun Drying Method

Since ovens are not generally available to the worker in the field, an alternate method has been developed which utilizes solar energy for the purpose of drying soil samples. In areas where the climate is warm and dry, results have been found to be very close to those obtained from oven-dried samples.

This procedure calls for the use of plastic sheets or of the same plastic bags in which the samples are stored to be exposed to the sun after the sample has first been weighed. Procedures utilized in the sun-drying of samples are:

- a. Determine weight of sheet or bag by weighing 100 of them and determining the average weight.
- b. Spread the sample out and break any clods present, thus providing maximum exposure of the soil to the sun.
- c. Place the samples in a convenient, protected area where maximum exposure to the sun is available.
- d. Exposure time

<u>Time of year</u>	<u>Sheet</u>	<u>Bag</u>
Hot Season	3 hours	5 hours
Cool Season	4 hours	7 hours

These tabulated times assume this number of hours of bright sunshine. Drying cannot be conducted during cloudy or partly cloudy weather.

Overnight drying is not recommended since wind or storms can ruin samples very quickly.

Note...these exposure times have been found to approach 1% of oven dry weights in Pakistan, where the climate is warm and dry and sun intensity is high.

Specifications of drying sheets or bags:

Sheets

- a. Sheets should be 2 to 6 mil polyethelene plastic, 24 inches square.
- b. Sheets need not be weighed if a special weighing dish is used.

Bags

- a. If the same bag is used for drying as that in which the sample is collected, larger bags are needed. 15" x 15" plastic bags are recommended so that they may be folded to provide a two-inch rim around the exposed sample. The use of the bag provides somewhat more protection against spillage than the sheet, and requires fewer supplies and less handling.

The Touch and Feel Method (TAF)

The touch and feel method is not intended to replace field samplings and laboratory techniques. Rather, it is intended to enable the technician to develop a practical, quick estimate in the field when decisions relative to water use or irrigation planning are necessary.

The attached table presents descriptions of the appearance of the soil as it is examined. First, determine the texture of the soil:

Wet a small handful of the soil and work it into an uniform consistency by squeezing and kneading it.

A coarse soil when squeezed will leave moisture in the hand. The sample shows little cohesion and will not form a "ribbon" when squeezed between the thumb and forefinger.

A light soil leaves a wet outline on the hand when squeezed. Shows some cohesion when manipulated and will form only a very weak "ribbon" when squeezed between the thumb and forefinger.

A medium soil leaves a slightly wet outline when squeezed in the hand. It shows definite cohesion, and will form a moderate ribbon (up to 1 inch in length) between the thumb and forefinger.

A fine soil hardly leaves a moisture outline when squeezed in the hand. It is strongly cohesive, and will sometimes ribbon out to almost two inches between the thumb and forefinger.

Once the basic textural group has been determined and proper column in the table has been chosen, the samples in the field moisture condition is examined. The procedure is to squeeze the sample into a ball, about an inch

in diameter. Test the ball for strength and compare its strength with the descriptions in the column of the table representing the textural grade of the sample. Estimate soil moisture deficiency in inches per foot of depth from the table...last column.

The chart assumes the average soil available soil moisture, at field capacity, for the four textural classes to be:

Coarse - 0.7 inches per foot

Light - 1.3 inches per foot

Medium - 1.8 inches per foot

Fine - 2.0 inches per foot

These values can be divided by 12 and multiplied by 100 to convert to available moisture on a volume basis. This figure divided by the bulk density of the soil will provide available moisture on a weight basis (which the gravimetric procedure provides).

Comparison of the Three Techniques

Actually the three techniques which are discussed here are not designed to replace one another. Rather, they are each utilized in that manner which will expedite the management program most efficiently.

The procedure which provides the true analytical analyses of soil moisture availability is the use of the oven. The other methods have been developed to supplement, not replace, this one. The accuracy of the sun-drying method is determined by the care with which the sample is handled; the temperature, humidity, and intensity of the sun. Its accuracy might not be dependable in cool or humid climates, but in warm, dry areas like Pakistan the results have been found to be practical and accurate when samples are properly handled and protected.

The TAF method is not intended to replace gravimetric procedures. It has been developed for use by the technician to make quick, practical field decisions. If this procedure is to be accurate and effective, the person using it should constantly calibrate his "feel" against gravimetric results. It is suggested that he develop a graph, similar to the following, on a regular basis.

EWUP

How to do it

Field Procedure



SOIL MOISTURE SAMPLING AND CALCULATION USING A KING TUBE SAMPLER

by Alan Early*

The king tube sampler is a useful tool to the water management specialist. When properly constructed and correctly used it can provide volumetric samples of soil to calculate dry bulk density as well as soil moisture percentages and plant food analyses. However, extremes in soil moisture percentages may limit density accuracy. In very dry soil some of the sample may often be left at the bottom of the hole, on the other hand, very wet soil will stick to the sides of the tube. In either case lower than actual density values may result.

A few precautions and suggestions have been developed which will assist in avoiding these pitfalls.

1. Be sure the tube is clean and free of rust. Clean and polish the tube regularly. Cover with a light film of oil if tube is not used regularly.
2. Measure the inside diameter of the cutting edge of the tube and check the exterior depth calibrations above the cutting edge. Reject the tube if any of the measurements are not within 0.005 ft (.01 centimeter).
3. Select representative sites from the field to be sampled. Areas within the field which appear different from the "average" should be sampled separately.
4. Align the tube vertically and strike the tube vertically into the ground allowing the pointed edge of the hammer to move inside the tube in an up and down motion. Never swing the hammer as a driving device.
5. Place a straight edge on the ground next to the hole as a reference point to stop the sample tube at each depth graduation.

*This How-To-Do-It was taken from The Problem Identification Handbook (April 1, 1980). Developed by the CSU-Pakistan Water Management Project sponsored by U.S. Agency for International Development, Contract No. AID/TAC-1100.

6. Remove the hammer from inside the tube and orient it horizontally (perpendicular to the tube) passing the hammer slot over the end of the tube. Rotate the hammer 90° in a horizontal plane and lift the tube slowly, vertically from the soil.
7. Place your left index finger over the cutting edge of the tube as it emerges from the surface of the soil to prevent sample spillage.
8. Invert the tube with top of tube over the container (moisture can with tight fitting lid or plastic bag) which is to keep the sample in proper moisture condition until weights have been determined. Force the sample loose by pushing it loose with the index finger. A clean, polished tube, properly constructed will easily release the sample into the container. Close the container immediately to prevent the loss of moisture. Do not allow unweighted sample to be exposed directly to the sun, especially samples collected in plastic bags.
9. Repeat steps 4 through 8 for as many different depth increments as needed.
10. Repeat steps 3 through 9 for at least two replicates in other representative sites of the field being sampled.
11. Weigh and record the weight of the wet sample in the field. Samples placed in plastic bags should be weighed immediately.
12. Dry the sample.
13. Reweigh the sample after predetermined drying time. (The sample is considered dry when no further weight changes occur.)
14. Make necessary calculations using the following procedures.
 - a. $\text{Volume} = 3.14 (D/2)^2 H.$
 - b. $\text{Water Weight} = (\text{wet weight of sample and container}) - \text{dry weight of sample and container}.$
 - c. $\text{Net dry weight of sample} = \text{dry weight (sample and container)} - \text{weight of container}.$
 - d. $\text{Percent moisture by weight} = \text{net} \frac{\text{weight of water}}{\text{dry weight of soil}} \times 100$
 - e. $\text{Field dry bulk density} = \frac{\text{net dry weight of soil}}{\text{volume of sample (cc)}} \text{ (gm)}$
 - f. $\text{Percent moisture by volume} = \text{field dry bulk density} \times \text{percent moisture by weight}$ or $\frac{\text{weight of water}}{\text{volume of sample}} \times 100$

- g. Approximate available moisture (inches per foot) $ASM = 12 \times \% MC \text{ Volume} - \text{Volume at wilting point where } \% MC\text{-Vol}$ at the wilting point is to come from laboratory analysis of soil moisture characteristic.

SOIL MOISTURE SAMPLING REPORT

Observers _____ and _____ Weight of plastic bag _____ g

Date _____ Hours Drying Time _____

Date Last Irrigation _____ Diameter of king tube _____ cm

Date of next irrigation _____ Volume of sample 6" = _____ cc 12" = _____ cc

Rep	Trtmt	Depth	WetWt (g)	DryWt (g)	WtH ₂ O	NetDryWt	%MC-Wt	DBD	%MC-Vol	ASM (in/ft)
_____	_____	1 (0-6")	_____	_____	_____	_____	_____	_____	_____	_____
_____	_____	2 (6-12")	_____	_____	_____	_____	_____	_____	_____	_____
_____	_____	3 (12-24")	_____	_____	_____	_____	_____	_____	_____	_____
_____	_____	4 (24-36")	_____	_____	_____	_____	_____	_____	_____	_____
_____	_____	5 (36-48")	_____	_____	_____	_____	_____	_____	_____	_____
_____	_____	6 (48-60")	_____	_____	_____	_____	_____	_____	_____	_____
_____	_____	7 (60-72")	_____	_____	_____	_____	_____	_____	_____	_____

Rep	Trtmt	Depth	WetWt (g)	DryWt (g)	WtH ₂ O	NetDryWt	%MC-Wt	DBD	%MC-Vol	ASM (in/ft)
_____	_____	1 (0-6")	_____	_____	_____	_____	_____	_____	_____	_____
_____	_____	2 (6-12")	_____	_____	_____	_____	_____	_____	_____	_____
_____	_____	3 (12-24")	_____	_____	_____	_____	_____	_____	_____	_____
_____	_____	4 (24-36")	_____	_____	_____	_____	_____	_____	_____	_____
_____	_____	5 (36-48")	_____	_____	_____	_____	_____	_____	_____	_____
_____	_____	6 (48-60")	_____	_____	_____	_____	_____	_____	_____	_____
_____	_____	7 (60-72")	_____	_____	_____	_____	_____	_____	_____	_____

Rep	Trtmt	Depth	WetWt (g)	DryWt (g)	WtH ₂ O	NetDryWt	%MC-Wt	DBD	%MC-Vol	ASM (in/ft)
_____	_____	1 (0-6")	_____	_____	_____	_____	_____	_____	_____	_____
_____	_____	2 (6-12")	_____	_____	_____	_____	_____	_____	_____	_____
_____	_____	3 (12-24")	_____	_____	_____	_____	_____	_____	_____	_____
_____	_____	4 (24-36")	_____	_____	_____	_____	_____	_____	_____	_____
_____	_____	5 (36-48")	_____	_____	_____	_____	_____	_____	_____	_____
_____	_____	6 (48-60")	_____	_____	_____	_____	_____	_____	_____	_____
_____	_____	7 (60-72")	_____	_____	_____	_____	_____	_____	_____	_____

Rep	Trtmt	Depth	WetWt (g)	DryWt (g)	WgH ₂ O	NetDryWt	%MC-Wt	DBD	%MC-Vol	ASM (in/ft)
_____	_____	1 (0-6")	_____	_____	_____	_____	_____	_____	_____	_____
_____	_____	2 (6-12")	_____	_____	_____	_____	_____	_____	_____	_____
_____	_____	3 (12-24")	_____	_____	_____	_____	_____	_____	_____	_____
_____	_____	4 (24-36")	_____	_____	_____	_____	_____	_____	_____	_____
_____	_____	5 (36-48")	_____	_____	_____	_____	_____	_____	_____	_____
_____	_____	6 (48-60")	_____	_____	_____	_____	_____	_____	_____	_____
_____	_____	7 (60-72")	_____	_____	_____	_____	_____	_____	_____	_____

Rep	Trtmt	Depth	WetWt (g)	DryWt (g)	WgH ₂ O	NetDryWt	%MC-Wt	DBD	%MC-Vol	ASM (in/ft)
_____	_____	1 (0-6")	_____	_____	_____	_____	_____	_____	_____	_____
_____	_____	2 (6-12")	_____	_____	_____	_____	_____	_____	_____	_____
_____	_____	3 (12-24")	_____	_____	_____	_____	_____	_____	_____	_____
_____	_____	4 (24-36")	_____	_____	_____	_____	_____	_____	_____	_____
_____	_____	5 (36-48")	_____	_____	_____	_____	_____	_____	_____	_____
_____	_____	6 (48-60")	_____	_____	_____	_____	_____	_____	_____	_____
_____	_____	7 (60-72")	_____	_____	_____	_____	_____	_____	_____	_____

EWUP

How to do it

Field Procedure



SOIL PROFILES AND WATER TABLES

by Doral Kemper*

The position of the water table is an indication of whether or not a drainage problem exists. A high water table means that something has to be done to reduce the amount of water in the soil. Under ordinary conditions in arid regions, the water table should not be occasionally higher than 1.2 meters below the soil surface, and most of the time it should be 2.0 meters or more below the soil surface. A shallow water table will cause salt to accumulate on the soil surface from direct evaporation. A high water table will also cause poor aeration conditions in the root zone of the plants.

If the water table is too high under irrigated conditions, some form of artificial drainage must be provided.

Where artificial drainage is required, it is important to know the location and position of the water table. It is also important to know the texture characteristics of the soil profile.

General Procedure

A hand auger, a power auger or a soil coring device is used to make a hole in the soil to a depth of two meters or more. The depth and texture of the various soil layers should be recorded. The depth at which free water is noticed should also be recorded. Observations of the position of the water table in the hole should be observed over a period of days or weeks or months, depending on the need. If the water table is too high, a drainage system should be considered.

Equipment Needed

Hand auger or power soil sampler capable of making a hole 5 cm or larger in diameter to a depth of two meters or more.

Surveying equipment and stakes for locating the water table holes both for surface position and elevation.

*This How-To-Do-It was taken from The Problem Identification Handbook (April 1, 1980). Developed by the CSU-Pakistan Water Management Project sponsored by U.S. Agency for International Development, Contract No. AID/TAC-1100.

Measuring tape to determine depth from the soil surface to the water table.

Detailed Procedure

In the area selected for study of a water table problem, lay out a regular grid location for the water table observation holes. The spacing may be 1 or 2 kilometers in large areas or as little as 50 meters in a normal spacing.

Make a vertical hole in the soil, keeping notes of the soil texture, structure, color changes, soil conditions and wetness for each of the layers. A special note should be made of the depth for the first appearance of visible water in the soil being removed.

The completed hole should be covered or protected so that animals will not step in it and the hole can be left for observation. Observations of the water level in the hole should be made periodically. Observations may be made hourly, daily, weekly, monthly or annually, depending on the need. For farm drainage design, daily observations are usually required. The observations consist of measuring and recording the distance from the soil surface to the water table using tape or a chain or a rod.

If elevation changes and slope of the water table are important, elevations of the soil surface should be determined at each auger hole for reference. Data from the observation holes can be used to make maps of depth to water table and water table contours.

If the hole is unstable or if long-term observations are needed, a perforated pipe surrounded with coarse sand can be used to line the hole.

EWUP

How to do it

Field Procedure



GUIDELINES FOR CUTTHROAT FLUME INSPECTION

by Alan Early*

Precise water measurement is necessary if good water management is to be realized. A useful saying is, "How can you on a farm manage water if the amount of water to be managed is not known?" Measuring water is the most basic requirement for developing an understanding of any irrigation system. First of all, the precision of water measurement is dictated by the accuracy with which the flow measuring device is constructed. Exact tolerances in fabrication are therefore required.

The following is a guideline, fill-in table, and check list for inspecting cutthroat flumes. All measurements of flume dimensions must be met within 1/16 in. (0.005 ft or 1.5 m) of the specified length, or within 0.5 degrees of the specified angle, if the flume is to be acceptable for field use. Flumes which do not meet these standards should be rejected.

*This How-To-Do-It was taken from The Problem Identification Handbook (April 1, 1980). Developed by the CSU-Pakistan Water Management Project sponsored by U.S. Agency for International Development, Contract No. AID/TAC-1100.

TABLE OF LINEAR DIMENSIONS Tolerance (0.005 ft)

	<u>Specification</u>	<u>Top</u>	<u>Middle</u>	<u>Bottom</u>	<u>Other</u>
W	_____	_____	_____	_____	_____
L	_____	_____	_____	_____	_____
$B_1 = W + L/4.5$	_____	_____	_____	_____	_____
$B_2 = W + L/4.5$	_____	_____	_____	_____	_____
$L_1 = L/3$	_____	_____	_____	_____	_____
$L_2 = 2L/3$	_____	_____	_____	_____	_____
$L_a = 2L/9$	_____	_____	_____	_____	_____
$L_b = 5L/9$	_____	_____	_____	_____	_____
H	_____	_____	_____	_____	_____
H_a	_____	_____	_____	_____	_____
H_b	_____	_____	_____	_____	_____

TABLE OF ANGLES MEASURED

Angles are measured from the vertical wall (or staff gauge) to the floor of the flume in the direction corresponding to the arrows in the attached diagram.

Tolerance: 0.5 degree

	Spec.	Measured		Spec.	Measured		Spec.	Measured
1.	_____	_____	6.	_____	_____	11.	_____	_____
2.	_____	_____	7.	_____	_____	12.	_____	_____
3.	_____	_____	8.	_____	_____	13.	_____	_____
4.	_____	_____	9.	_____	_____	14.	_____	_____
5.	_____	_____	10.	_____	_____	15.	_____	_____

GENERAL QUALITATIVE MEASURES AND OBSERVATIONS

- ____ 1. Staff gauges should be located precisely at distances L_a and L_b from the throat, respectively, with these distances being measured to the center of the staff gauge markings.
- ____ 2. Staff gauges installed perpendicular to the floor of the flume.
- ____ 3. When installed with stilling wells, the centerline of the piezometer holes for water entry must be precisely at distances L_a and L_b from the throat (tolerance: .005 ft).

- ___ 4. When installed with stilling wells, the staff gauge in each stilling well must start at exactly the same datum (floor of the flume) in the stilling well as in the respective converging and diverging sections.
- ___ 5. Sides must be perpendicular to the floor throughout the converging inlet and diverging outlet sections.
- ___ 6. Sides must be plane number surfaces, free of buckles and bulges.
- ___ 7. The bend of the walls in the throat section must be sharp and perpendicular to the floor along the direction of the flow.
- ___ 8. A cross brace should be placed across the top of the flume at the center of the converging inlet section and at the center of the diverging outlet section with these cross braces being parallel to the flume floor.
- ___ 9. Metal strips should be placed on top of the flume walls on both sides of the flume and near the center of both the inlet converging section and outlet diverging section, with all four metal pieces being parallel to the floor of the flume.
- ___ 10. The floor of the flume should be a flat plane surface and free of bulges.
- ___ 11. Bolts or other means of attaching the staff gauges to the flume walls (if stilling wells are not used) should not result in any protrusion into the flow.

EWUP

How to do it

Field Procedure



HOW TO READ STAFF GAUGE ON FLUMES AND HOW TO DETERMINE DISCHARGE FROM THE READING

by Alan Early and Wayne Clyma*

STAFF GAUGE

The staff gauge is usually a metallic scale to measure the water surface level from a fixed reference point. It tells the depth of water or the static head acting at any point.

On this gauge, one foot is divided into 10 equal divisions and each division is labelled. (1, 2, 3, etc. ...up to 9). These divisions are made with black lines on white paint. After each ten divisions, foot marks are also labelled, 1.0, 2.0, etc., up to the maximum desired depth. The 1/10th ft divisions are further divided into 10 divisions each (1/100 ft), as shown on the diagram.

HOW TO READ THE GAUGE

Suppose that the water surface level is "L" as shown in the diagram. The reading is between 0 and 1.0 ft, and calibrations 0.4 and 0.5 ft. In this illustration, the water level (L) is above the 0.4 ft division and below the 0.5 ft and below the 1.0' reading on the gauge. The first recording, therefore, is 0.4 ft. The final recording then is obtained by adding the 1/100 ft calibrations which are found between 0.4 ft and the water level, L. The 1/100 ft calibrations are alternately black and white. Reading downward from 0.5 to 0 they are black/1, white/2, black/3, white/4, black/5, white/6. When they are read from the 0.4 calibration upward, they are white/1, black/2, white/3, black/4. Thus the water level L is $0.4 \text{ ft} + 4/100 \text{ ft} = 0.44 \text{ ft}$, or $0.5 \text{ ft} - 6/100 \text{ ft} = 0.44 \text{ ft}$.

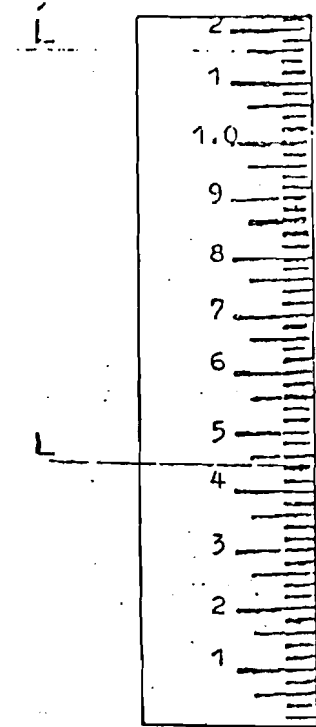

*This How-To-Do-It was taken from The Problem Identification Handbook (April 1, 1980). Developed by the CSU-Pakistan Water Management Project sponsored by U.S. Agency for International Development, Contract No. AID/TAC-1100.

Similarly, if the water level is above the 1.0 ft division upon the gauge, the steps are the same except that the reading is 1.0 ft + the tenths + the 1/100ths. Thus as illustrated, if L' is the water level, then the reading is:

	a.	1.00 ft
plus	b.	.10 ft
plus	c.	.06 ft
total	d.	1.16 ft

Gauge readings above the 2, 3, 4, etc. calibrations are computed in the same manner.

Note that all labels are at the top of each black line so that the top of each black line indicates an even number and the bottom of that line indicates an odd number.

Example:

- (1) Reading at Section AA' is 1.06 (Figure 2).
- (2) Reading at Section BB' is 0.37 (Figure 3).
- (3) Reading at Section CC' is 2.00 (Figure 4).

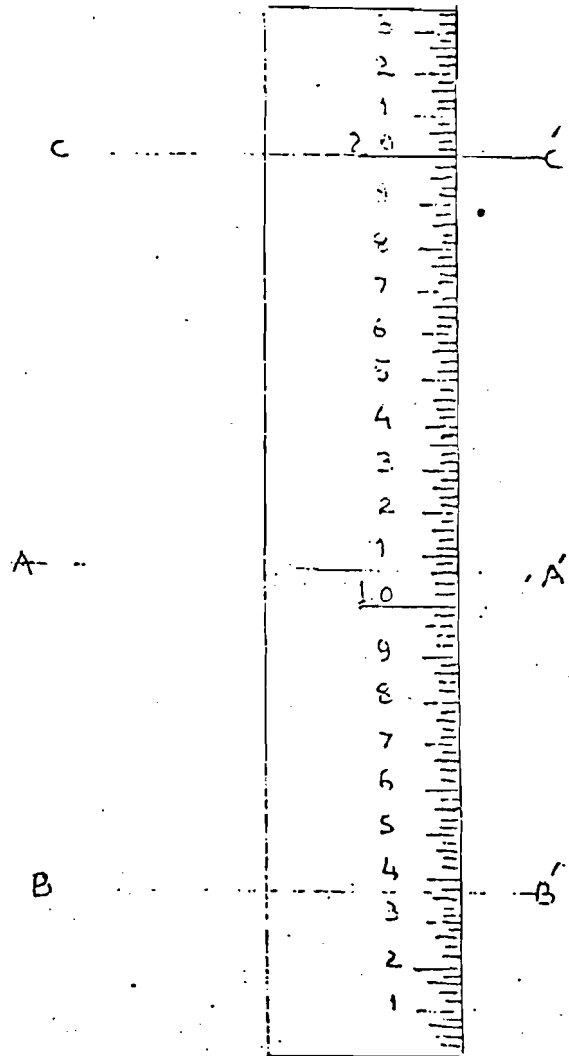

DETERMINING THE DISCHARGE

To determine the discharge with flumes, water levels at both the upstream and downstream wells are measured with staff gauges fixed on the flumes. The reading of the upstream gauge is h_a and that of the downstream gauge is h_b . When h_a and h_b are known, the discharge can be determined from the flow calibration tables which are provided with the equipment.

There are two types of flow calibration tables, one for free flow and the other for submerged flow conditions.

If h_b/h_a is less than 65%, the free flow calibration table will be used and if h_b/h_a is greater than 65% then the submerged flow calibration table must be used.

For example, in an 8" x 3' cutthroat flume, if h_a is 0.50 and h_b is 0.25, $h_b/h_a = 0.25/0.50 = 50\%$. 50% is less than 65%, so the free flow calibration table will be used and one can easily determine the discharge of 0.83 cubic feet per second (CFS) in the flow calibration table written in front of 0.50 h_a . If h_a is 0.48 and h_b is 0.36, then $h_b/h_a = 0.36/0.48 = 75\%$ which is more than 65% so the submerged calibration table will be used and the discharge of 0.7 cfs can be observed in front of 0.48 h_a under 12 ($h_a - h_b$).

The flow calibration tables used in this example are attached and the concerned readings are shown underlined.

PRECAUTIONS FOR USE OF STAFF GAUGE

1. Make sure that the gauge is installed vertically.
2. All gauges of the flume should give the same reading in standing water, with the flume properly leveled. Incorrect installation of gauges or the flume will result in wrong measurements.
3. While reading the gauge, there should be no disturbance in the water surface near the gauge.
4. If there is disturbance, that should be removed by placing the hand parallel to the vertical side of the flume.
5. If a disturbance in the surface is not easily removed, then the average of minimum and maximum readings should be taken.
6. Pull out all the mud and dirt from the stilling wells.* It can affect your reading by blocking the inlet ports.

*To avoid error due to disturbance in the water surface level near the gauges, flumes are usually provided with stilling wells in which gauges are installed and readings of h_a and h_b in the stilling well gauges are used for discharge calculations.

Table 1. Free flow calibrations for selected cutthroat flumes
(values listed are discharge in cfs).

a_{ft}	41NX3FT	81NX3FT	121NX3FT
0.10	0.02	0.04	0.07
0.20	0.08	0.15	0.23
0.30	0.16	0.32	0.49
0.40	0.27	0.55	0.83
0.50	0.41	0.83	1.26
0.60	0.57	1.16	1.76
0.70	0.76	1.54	2.33
0.80	0.97	1.97	2.98
0.90	1.20	2.45	3.71
1.00	1.46	2.97	4.50

Table 2. Submerged flow calibrations for 8" x 3' cutthroat flume
(values listed are discharge in cfs).

h_a							
ft	0.10	0.12	0.14	0.16	0.18	0.20	0.22
0.50	0.8	0.8	0.8	0.8	0.8	0.8	0.8
0.52	0.8	0.9	0.9	0.9	0.9	0.9	0.9
0.54	0.9	0.9	0.9	0.9	0.9	1.0	1.0
0.56	0.9	1.0	1.0	1.0	1.0	1.0	1.0
0.58	1.0	1.0	1.1	1.1	1.1	1.1	1.1
0.60	1.1	1.1	1.1	1.1	1.1	1.2	1.2
0.62	1.1	1.1	1.2	1.2	1.2	1.2	1.2
0.64	1.2	1.2	1.2	1.3	1.3	1.3	1.3
0.66	1.2	1.3	1.3	1.3	1.4	1.4	1.4
0.68	1.3	1.3	1.4	1.4	1.4	1.4	1.4
0.70	1.3	1.4	1.4	1.5	1.5	1.5	1.5
0.72	1.4	1.5	1.5	1.6	1.6	1.6	1.6
0.74	1.5	1.5	1.6	1.6	1.7	1.7	1.7
0.76	1.5	1.6	1.7	1.7	1.7	1.8	1.8
0.78	1.6	1.7	1.7	1.8	1.8	1.8	1.9
0.80	1.7	1.7	1.8	1.8	1.9	1.9	1.9
0.82	1.7	1.8	1.9	1.9	2.0	2.0	2.0
0.84	1.8	1.9	2.0	2.0	2.0	2.1	2.1
0.86	1.9	2.0	2.0	2.1	2.1	2.2	2.2
0.88	1.9	2.0	2.1	2.2	2.2	2.3	2.3
0.90	2.0	2.1	2.2	2.2	2.3	2.3	2.4
0.92	2.1	2.2	2.3	2.3	2.4	2.4	2.5
0.94	2.1	2.3	2.3	2.4	2.5	2.5	2.6
0.96	2.2	2.3	2.4	2.5	2.6	2.6	2.6
0.98	2.3	2.4	2.5	2.6	2.6	2.7	2.7
1.00	2.4	2.5	2.6	2.7	2.7	2.8	2.8

EWUP

How to do it

Field Procedure



COLLECTING SOIL SAMPLES FOR
SOIL FERTILITY AND SALINITY ANALYSES

by Bill Stewart*

The analyses of the soil sample provides a quick, practical way for the farmer and the field supervisor to obtain advanced information about the fields with which they will be working during the following production season. Cultural decisions can be made in advance, thus allowing for more efficient planning for time and supplies when the soil is prepared for planting.

If the tests are to be of value to the farmer, he must be able to associate each of them with a particular set of field conditions. Familiarity with the fields and with the situations which the tests represent will enable him to formulate his production plan ahead of time. The purpose of the sample manner in which the soil sample is collected and prepared, therefore, becomes very important. Rather precise techniques have been developed which, when followed, will provide accurate information about the fields under the conditions which the soil sample represents--it must be emphasized that samples which are not representative, or which are improperly handled are worthless.

Tools

The sample can be collected with the shovel or spade, normally used on the farm for other work. Soil sampling augers and tubes, however, simplify the collection. In Pakistan, the King Tube Sampler is widely used. Sampling equipment must be clean and free from rust to eliminate pollution--clean, well-kept equipment is also easier to use. If micronutrient analyses are to be performed, stainless steel and plastic tubes and buckets are recommended to eliminate any possibility of introducing iron and zinc into the sample from the equipment.

* This How-To-Do-It was taken from The Problem Identification Handbook (April 1, 1980). Developed by the CSU-Pakistan Water Management Project sponsored by U.S. Agency for International Development, Contract No. AID/TAC-1100.

1. USE ANY OF THE TOOLS SHOWN BELOW TO TAKE SAMPLES. TAKE SAMPLE TO THE PLOW DEPTH (USUALLY _____).

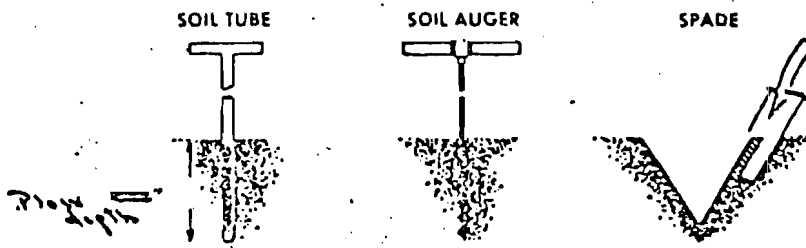

The field supervisor who is responsible for sampling procedures will gradually develop a "routine" which simplifies the sampling procedure and reduces the time involved. A rather definite procedure is followed:

First: The person who is sampling the field must become familiar with the various situations within the field and sample accordingly. Each sample must represent a specific field situation and condition, and be labeled, bagged, and packaged accordingly.

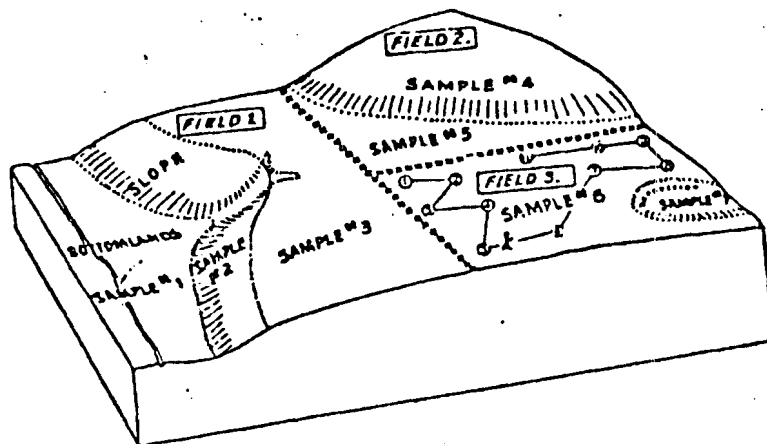

EACH SAMPLE SHOULD REPRESENT A UNIFORM AREA SIZE UP THE AREA AND OBSERVE THESE VARIATIONS

DIFFERENCES IN TEXTURE (SAND, SILT, CLAY), COLOR, SLOPE, DEGREE OF EROSION, DRAINAGE, PAST MANAGEMENT (FERTILIZATION, ROTATION, ETC)

Second: Using clean equipment, collect 10 to 20 cores from each selected area. (If the spade is used, the "core" is a sample of the furrow slice, 1 inch wide, from the center of the blade.) Most of the fertility elements are normally contained in the upper six inches of the soil, so sample to the depth of the "plow slice"--usually 6 to 8 inches. Additional

samples may be taken at intervals from the entire root zone for salinity analyses, when necessary.* If subsoil samples are to be taken, either for fertility or salinity analyses, collect a second sample from the same bore from the 6" to the 12" level, etc., until the desired depth is reached. Label and submit these samples separately.

Third: Thoroughly mix the sample, breaking up any clods which might be present. Dry the sample (air dry, do not heat). Spread the sample upon a flat, clean surface and "quarter" the sample until about a quart (about 1 liter volume) of soil remains for fertility analyses. Samples about twice this size should be collected for complete salinity analysis.

Fourth: Package the sample in a strong, clean container.

Fifth: Be sure to fully identify each sample and record the information needed to identify it with the field situation from which it was collected.

Sixth: Submit complete information to the laboratory. (Their information can only represent that which they are given.) Package the samples and deliver them to the laboratory with that information.

This completes the sampling process for 1 field condition. Repeat for each segment of the field which is sampled.

Be sure that samples are protected against breakage and mixing on their way to the laboratory.

*For salinity analyses, subsoil samples are always required.

EWUP

How to do it

Field Procedure



INSTALLATION AND USE OF CUTTHROAT FLUMES FOR WATER MEASUREMENT

by W. A. Moskin, W. Clyma, and A. Early*

A considerable amount of work has been done on the development of water measuring equipment including flumes, weirs and flow meters. The cutthroat flume is the latest development in this series. It has specific advantages:

1. Satisfactory water measurements can be made under both free and submerged flow conditions.
2. Head loss through this flume is low, even lower than the Parshall flume which has been used for many years.

In summary, this flume provides accurate water flow rate measurement in the flat gradient channels commonly encountered in irrigation systems. The cutthroat flume is easily constructed due to its flat bottom and consistent wall geometry. Its advantages have resulted in wide acceptance by many involved in water management work in flat gradient channels, such as irrigation and drainage channels.

THEORETICAL CONSIDERATIONS

A. Flume Selection

A flume with the proper throat size must be selected. Flow measurement is not as accurate at low heads or at very high heads. Tables 1 and 2 may be utilized as a guide to selection of flume throat width for the flume lengths of 3 feet or 1 meter, which are commonly used in on-farm water management research (see Tables 1 and 2).

B. Flume Dimensions Checkup

All flume dimensions must be measured to be sure that the flume has been constructed properly. If dimensions of the throat vary more than 1/16 in., reject the flume. Check also for general appearance of the flume. The

*This How-To-Do-It was taken from The Problem Identification Handbook (April 1, 1980). Developed by the CSU-Pakistan Water Management Project sponsored by U.S. Agency for International Development, Contract No. AID/TAC-1100.

Table 1. Free flow calibrations for selected cutthroats flumes
(values listed are discharge in cfs).

h_a	41NX3FT	81NX3FT	121NX3FT	161NX3FT	81NX6FT	161NX5FT	241NX6FT
0.10	0.02	0.04	0.07	0.09	0.06	0.11	0.17
0.20	0.08	0.15	0.23	0.31	0.17	0.35	0.54
0.30	0.16	0.32	0.49	0.66	0.34	0.69	1.05
0.40	0.27	0.55	0.83	1.12	0.55	1.11	1.69
0.50	0.41	0.83	1.26	1.68	0.79	1.60	2.44
0.60	0.57	1.16	1.76	2.36	1.07	2.16	3.29
0.70	0.76	1.54	2.33	3.13	1.37	2.79	4.24
0.80	0.97	1.97	2.98	4.00	1.71	3.47	5.28
0.90	1.20	2.45	3.71	4.97	2.08	4.21	6.41
1.00	1.46	2.97	4.50	6.03	2.47	5.01	7.62

Table 2. Free flow calibrations for selected cutthroat flumes, metric units (Q^* , cms).

h_a^* meters	10X90CM	20X90CM	30X90CM	20X180CM	40X180CM	60X180CM	30X270CM	60X270CM	100X270CM
.025	.000	.001	.001	.001	.002	.003	.002	.004	.007
.050	.001	.003	.004	.003	.007	.011	.006	.012	.020
.075	.003	.006	.009	.007	.014	.021	.011	.022	.038
.100	.005	.011	.016	.011	.022	.033	.017	.035	.059
.125	.008	.016	.024	.015	.032	.048	.024	.049	.083
.150	.011	.023	.034	.021	.043	.064	.032	.066	.111
.175	.014	.031	.045	.027	.055	.083	.041	.083	.141
.200	.018	.039	.057	.034	.068	.104	.051	.103	.174
.225	.023	.049	.071	.041	.083	.126	.061	.123	.209
.250	.028	.059	.086	.049	.099	.150	.072	.146	.246
.275	.033	.070	.102	.057	.116	.175	.083	.169	.285
.300	.039	.082	.120	.066	.134	.202	.095	.193	.327

walls should be vertical and perpendicular to the flat bottom. The converging and diverging sections should be fabricated according to specifications. Check all welded joints. If welds are found improper, the flume should be rejected.

C. Gauge Installation

Check the gauges. Gauges and inlets to the stilling wells reading the upstream head (h_a) as well as the downstream head (h_b) should be checked against the specifications. If the flume is equipped with stilling wells, check the water level next to the staff gauges as compared to the level in the stilling wells in standing water with the flume properly leveled. Incorrect installation will cause erroneous discharge readings.

D. Orientation for Leveling

If the flume must be installed in a channel with water flowing in it, make sure that two longitudinal and transverse locations on the flume top are parallel with two similar locations on the flume bottom. As close to the flume throat as possible, preferably on the converging section of the flume, place a short (about 6 in. long) carpenter's level in the transverse direction of the floor of the flume and bring the bubble to the level position. Likewise, bring the flume to a level position in the longitudinal direction. Find the same transverse level position somewhere on the top of the flume, either in the throat region, on the crosspiece at the start of the converging section, or on the crosspiece at the start of the diverging section. Mark this position for later leveling the flume in flowing water. Likewise for longitudinally leveling, place the level on top of the walls of the converging or diverging section of the flume. Wherever the bubble comes to the center, mark that position on the top of the walls. Always use these two marked positions to level the flume if it must be installed in flowing water, otherwise always use the floor of the flume to insure that the flume is installed in a level position.

Check these predetermined positions occasionally with reference to the flume bottom, as the flume may become deformed with long continued use.

INSTALLATION AND OPERATIONAL CONSIDERATIONS

Experience reveals that installation of a flume in the channel for flow measurement does not always make a farmer happy. His complaint is that the flume has "eaten" much of his water. If the channel has a flat gradient with very little freeboard, and the flume has been installed for free flow

conditions, considerable water will be stored in the irrigation (or drainage) channel above the flume. This creates an uncontrollable situation for the farmer as well as the person making discharge measurements. The upstream section of the channel may overtop, causing spillage, and great concern on the part of the farmer. Until steady state conditions are achieved, the measured discharge is much less than that passing through that point prior to flume installation. These difficulties, and others, force the development of proper installation techniques, which in turn facilitate measurements and minimize the farmers complaints about our friend, Mr. C. T. Flume for "eating" his water.

Helpful suggestions:

1. Establish an amiable acquaintance with the farmer. Explain your mission to him, completely.
2. Never approach the farmer bureaucratically. Treat him as the important person he is.
3. Develop friendly relationships with all farmers concerned.
4. Remember, the farmer in whose channel the flume is installed is very important to us, without his cooperation our work is meaningless.
5. Attempt to convince the concerned farmer that our mission is to help him achieve better water management.
6. Never make false promises to win favors (getting his water supply increased, etc.). Adverse relationships in the future will result.
7. If we fail to make a farmer understand the program, it is better not to argue. Wait for another cooperative farmer to irrigate. Make measurements there.
8. Always remember that most irrigation channels have flat gradient beds with very little freeboard. Take some time to decide about the site for flume installation. With the cutthroat flume, good discharge measurements can be made, even under submerged flow conditions. However, submergence should not exceed 90% if possible. Higher submergence will reduce energy loss, but the problem of the upstream section being overtopped could be minimized alternatively through careful installation and/or by building up the banks of the upstream channel. However, where conditions permit (steep-gradient conditions with more freeboard) installation should be for free flow conditions.

9. The flume should be placed in the center of the channel. It should be parallel to the direction of water flow in the channel.
10. The sides and bottom and around the flume walls should be properly sealed so that there are no leaks beside nor under the flume. Sandy soil conditions impose serious leak problems. Plastic sheets or cloth used as a cutoff wall in the surrounding soil can be used to overcome this problem.
11. The flume should be properly leveled both in the longitudinal and in the transverse direction. For this purpose, the flume bottom can be used while installing it in a dry channel. For installation in flowing water, the two reference points already marked on the topside of the flume walls can be used.
12. Before recording readings of the upstream and downstream gauges, always check for leaks along the sides and underneath the flume. The inside bottom of the flume should be checked and cleaned of any sediment or trash as this will cause h_a to increase and result in an erroneous reading. Also, make sure that the flume is still in a level position both longitudinally and transversely. If leaks are observed, stop them, and if the level is disturbed, relevel the flume. Repeat this process before recording each reading of the gauges.

INTERPRETATIONAL CONSIDERATIONS

Recording the gauge readings and determining the discharge from the rating tables is the easiest step in the flow measurement process. Who can answer with full confidence that flow measured with this flume is quite correct? To answer this question confidently requires more than simply recording gauge readings.

Experience has shown that on flat-gradient channels the flume has to be installed much longer before it reaches a steady-state flow condition than is necessary for steep-gradient channels. Short period installations may often lead to wrong conclusions. The section through which the water flows is restricted to a much smaller width through the flume as compared to that upstream from the flume. This imposes a problem of water storage in the upstream section of the channel and a smaller volume of flow through the flume during the initial period of flume installation. Sufficient time should be given to allow the channel storage to stop increasing, and the

flow through the flume to equal the steady state flow in the channel. In short, one must wait long enough after the flume is installed so that equilibrium conditions between inflow above the flume and outflow through the flume are established. This can be noted easily with the volume of flow becoming constant (the h_a gauge reading doesn't change with time) as the water level in the upstream section of the channel ceases to increase.

A. Water Measurement Applications

The cutthroat flume is a flow measuring device. It is simple in construction, easy to install and gives reasonable accuracy in flow measurement, both under free flow and submerged flow conditions. Proper water management plans a vital role in the economic utilization of water resources. For better water management, it is essential to know the rate of flow through any water flow system and to know how much water actually enters a specific field. These questions are best answered by using a cutthroat flume at various locations in a water conveyance channel. Select any convenient length of the conveyance system. Install the flume at the starting point and another flume at the end of that selected length. The ratio of the second flow volume to the first flow will provide us with the conveyance efficiency of that portion of the water delivery subsystem. Use the second flow volume to determine the depth of water applied to a specific field. In the above example, the first flume is installed as close to the channel inlet as possible and the second as close to the field as possible. From the depth of water applied, calculations of the water application efficiency can be made. Suggestions are given below on evaluation of delivery and application efficiencies.'

B. Measurement Installation

The first flume should be installed close to the irrigation channel inlet. The most important point about the first flume installation is whether or not submergence of the inlet occurs. By inlet submergence is meant the reduction in inlet discharge due to water backup in the channel because of flume installation. The effect can be noted by installing another flume about 1,000 feet below the first one. If, after pulling out the first flume, no change in flow is observed at the second, then one can be confident that the first flume is not submerging the inlet. If some increase in flow occurs at the second flume, then a location at a slightly greater distance from the inlet must be used for the first flume. Continuous adjustment in the position of the first flume is necessary until

no change occurs in the flow through the second flume after removing the first one. Before installing the flume near the inlet, record the water surface elevations in the irrigation canal upstream from the inlet and in the channel just below (downstream from) the inlet. If these two elevations differ by less than half a foot (15 cm), one should check as described above to see if flume installation has submerged the inlet. After the flume installation, there should be no change in the water surface elevations of the upstream canal. The upstream section of the flume should show some increase in elevation. The flume should be installed in such a position that the increase in water level in the irrigation channel is as small as possible when there is a danger of submerging the inlet. In doing all this, highly submerged flow conditions which would endanger our measurement accuracy should not result. The flume should not be installed at more than 90 percent submergence. If the channel downstream from the inlet has a steep gradient, then the chances of the inlet being submerged with flume installation are small, but if the channel has a flat gradient, then inlet submergence must be given serious consideration.

The volume of flow which passes through the inlet or through the flume installed close to the inlet has to go somewhere through the conveyance system to be utilized for irrigation purposes. How much of this discharge is being effectively used for irrigation purposes is another area of interest for the water management specialist. If some of this inlet discharge does not reach the fields, then we must ask "Where does it go?" These and many other questions force a person who is interested in better water management to further investigate the situation.

Determination of volume of flow through a certain length of conveyance system requires installation of another flume. This flume must be installed as close to the fields being irrigated as possible, making certain that no spillage losses are caused in the upstream section of the channel. The discharge measurement made by this second flume will serve five purposes:

1. Determine the conveyance efficiency of the water delivery subsystem.
2. Determine the overall water losses of the system.
3. Evaluate the depth of application of irrigation to a specific field.
4. Evaluate the application efficiency to specific fields (with additional measurements).

5. Evaluate the overall irrigation efficiency of a particular irrigation system.

All of the above listed evaluations make this water measurement the most important element of the entire study. Erroneous measurement will jeopardize the whole water management investigation.

The following steps will help to a great extent to get this measurement with reasonably accuracy.

1. After the second flume is installed, make sure that one person is designated to walk along the channel back to the first flume which has been installed near the inlet. This person should make note of spills, stealing bank leaks, trading between the farmers, bank failures, water diversions into other branches, and anything special which might affect the discharge measurement at the second flume. He should be instructed to keep a record of all these happenings with time.
2. When the second flume is installed, the flow is reduced for the initial periods following installation. In flat gradient channels, a lot of water is stored in the upstream section of the channel. Sufficient time should be allowed to dissipate this storage, otherwise false conclusions are likely. Wait long enough after flume installation to achieve steady flow conditions. This can be noted when the flow rate becomes constant (the h_a gauge reading does not change with time) if there are no changes in the upstream section of the channel.

C. Water Delivery Efficiency

Water delivery efficiency is the ratio of flow at the second flume to the flow at the first. For example, if the discharge at the second flume is 1.2 cubic feet per second (cusec) and that for the first flume is 1.8 cusecs, the deliver efficiency is:

$$E_d(\%) = \frac{100 (\text{flume 2})}{(\text{flume 1})} = \frac{1.2}{1.8} \times 100 = 67\%$$

D. Irrigation Channel Losses

Irrigation channel losses consist of seepage from the channel into the underlying groundwater and of spills which occur from leaky banks, overtopping the banks of the channel, etc. Losses may be measured or reported in several ways. One method of reporting the loss is the percent loss which is:

$$\text{Loss (\%)} = 100 - E_d(\%) = \frac{\text{flume 1} - \text{flume 2}}{\text{flume 1}} \times 100 = \frac{0.6}{0.8} \times 100 = 33\%$$

Another method is a discharge rate per unit length of channel. Assume the distance between the above flumes is 2400 ft:

$$\text{Loss} = \frac{\text{flume 1} - \text{flume 2}}{\text{length of channel}} = \frac{0.6}{2.4} = 0.25 \text{ cubic feet per second per 1000 feet}$$

Using cusecs/1000 feet as a measure of loss permits the direct comparison of the loss rate for different channels and lengths of channel. The channel loss rate does appear to increase with increasing discharge and decrease with increasing length of watercourse, so this method of reporting loss may also be considered.

Probably the most correct method for reporting loss is in terms of a seepage rate. The loss between two locations along the irrigation channel is measured. The length of the section and the wetted perimeter at several locations in the channel is measured. The average wetted perimeter is calculated and the loss may be reported as: (using 5 feet as an assumed average wetted perimeter)

$$\text{Loss} = \frac{\text{flume 1} - \text{flume 2}}{(\text{length})(\text{wetted perimeter})} = \frac{0.6}{(2400)(5)} = 51.84 \text{ in./day} = 2.16 \text{ in./hr}$$

E. Water Application

The water application to a field is determined by the flow rate, the time of application, and the area of the field, as follows:

$$qt = dA$$

q = flow rate in cusecs

t = time in hours

d = depth of application in inches

A = area of field in acres

If the flow at flume 2 near the field averages 1.2 cusecs during the time period of 2.25 hours, and the water is being applied to a field of 150 ft x 200 ft, which is approximately 0.69 acres, then the water application is:

$$d = qt/A = \frac{(1.2)(2.25)}{0.69} = 3.9 \text{ in.}$$

The amount of water applied is 2.9 acre inches per acre.

F. Application Efficiency

The application efficiency is computed as the amount of water stored in the soil, or the soil moisture deficiency, divided by the amount of water applied to the field. Determination of soil moisture deficiency may be

accomplished by several procedures, the most simple of which is soil moisture sampling. If the soil moisture deficiency was 2.3 inches, then the applications efficiency for this example equals:

$$EA = \frac{(\text{amount of water stored in the soil})}{(\text{amount of water applied to the field})} = 100 \frac{(2.3)}{(3.9)} = 59\%$$

G. Irrigation Efficiency

The irrigation efficiency is determined as the product of the deliver efficiency and the application efficiency. It is a measure of the effectiveness of the water used that is available at the inlet. For the examples already cited, the irrigation efficiency is calculated as:

$$E_i = E_d \times E_a = 67 \times 59 = 40\%$$

Additional information may also be derived from these basic flow measurements, but these are some important examples.

EWUP

How to do it

Field Procedure



FIELD AND WATERCOURSE ORIENTATION MAPPING USING PLANE TABLE AND PEEP-SIGHT ALIDADE

by Wayne Clyma and Alan Early*

The plane table and alidade, Figure 1, are frequently used instruments where layout maps are needed of irregular field and watercourse orientations. This offers the advantages of preparing the map while surveying is done and permits checking the watercourse and field layout as shown on the map with the actual layout. Also, where the design of, for example, a farm pond, is completed as soon as a map has been prepared, the design can be completed and staked all in one operation. No return trip to an office to prepare the map, make and design, and then another trip to the field to stake the dam, pond, and spillway is necessary. The principal disadvantage of using the plane table and alidade is the extra field time necessary. When bad weather occurs, no work is possible.

The basic equipment for the plane table and alidade method of mapping consists of a tripod, drawing board, alidade equipped with peep-sight alignment hairs, rod, tape, and pencil, paper and scale for preparing the map. Paper is fastened to the board and positions are plotted on the paper by sighting through the alidade for direction, and determining the distance by taping.

THE PLANE TABLE

The plane table (Figure 1) is a rectangular board (1) usually 18 x 31 inches. (46 x 79 cm) with a means for attaching it to a tripod. The top surface of the board is provided to attach a sheet of mapping paper.

The table is leveled by changing the position and the lengths of the legs. A small spirit level is provided for leveling the table (2).

* This How-To-Do-It was taken from The Problem Identification Handbook (April 1, 1980). Developed by the CSU-Pakistan Water Management Project sponsored by U.S. Agency for International Development, Contract No. AID/TAC-1100.

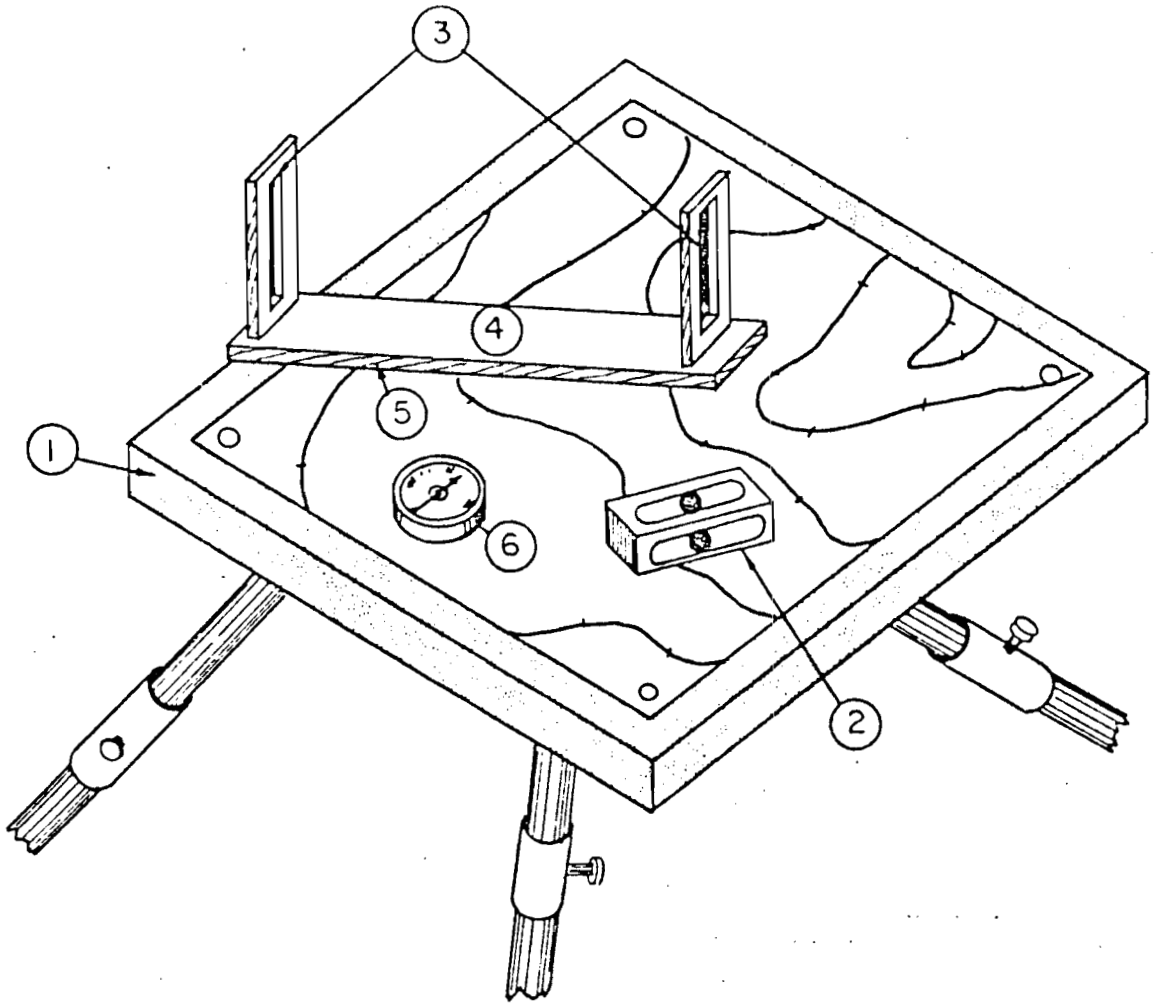

Figure 1. The plane table and alidade.

THE ALIDADE

The alidade in Figure 1 has two peep-sight brackets (3) with the vertical hairs separated by a distance of 18 inches. The alidade has a linear, usually brass, base (4) that supports it when resting on the table. One edge of the support (5) is usually leveled and this is the sighting edge. A separate, small magnetic compass (6) is provided for proper orientation of the plane table.

SETTING UP THE PLANE TABLE

The tripod and plane table are set up at an appropriate central location with respect to the line of sight for field layout or watercourse to be mapped. Using the level bubble on the separate level provided, the table is leveled. Leveling the table is sometimes difficult. The table is then rotated in a horizontal plane until magnetic north is the top of the map, or until another reference direction has been selected. The location of the instrument is designated on the map either arbitrarily or by using other known points to determine instrument location. A map can then be prepared using the alidade to sight locations and the tape to determine distances.

Alidades of other types can be used to determine both elevation and stadia distances. Because of the difficulties of maintaining a precisely leveled table, the surveyor may find it advantageous to use the plane table for locations and the farm level for elevations. This procedure may seem unnecessary (duplication of equipment). However, use of the level eliminates most of the difficulties of keeping the table level for good elevation control. Where a plane table and alidade are available, a level is usually available. One experienced surveyor for both level and table can usually keep two experienced rodmen busy.

ORIENTING THE PLANE TABLE

Location of the instrument on the map that is to be made is usually accomplished by two methods: (1) compass and (2) backsighting.

To orient the table by compass, the alidade is placed in the direction that is desirable for a north-south line. The table is then rotated until the compass needle points to magnetic north. The board is clamped and a line is drawn on the paper for future reference and to periodically check the orientation of the board.

Orientation of the board by backsighting requires that two points be located in the field. They may or may not be located on the map. If not located on the map, the orientation of the line is assumed for best use of the paper for construction of the map, then the orientation of the line is assumed for best use of the paper in constructing the map. Distances in all directions may be estimated and scaled to make sure that the scale selected will permit all the area to be mapped to be included.

If two points (A and B) are already located on the map, the instrument can be located at either point. The alidade is then pointed along the A-B line and the table is rotated until A (or B) is sighted and aligned with the vertical hair.

If point A is located on the map and point B is a more desirable instrument location, then the instrument is set up at point A. The table may be initially oriented by compass or by some other known line. The instrument is then sighted at point B and a line is drawn. The distance to B can be measured by pacing or taping, depending upon the accuracy required. B is then marked. The instrument is moved to point B, set up, and the alidade pointed along line B-A on the map. The table is rotated until the vertical hair is aligned on point A.

After the table has been oriented by either of the methods, several distance objects should be located and short lines identified at the edge of the map with a description of what the objects are. The orientation of the table can then be checked periodically without having the rodman return the point A. By carefully selecting well-defined objects on the skyline, reorientation of the table is more accurate. The large distances require minute adjustments for proper orientation. A straight pin is usually placed in the table at the point representing instrument location. The alidade is then kept against the pin when sighting locations. Even with the pin, care is required in keeping the line of sight of the alidade radiating from the station.

Points on the map that require precise locations may be located by intersection or triangulation. With the instrument at one location, lines are drawn that represent the line of sight to the desired points. The instrument is relocated by carefully taping the distance to the new location. Line of sight lines are drawn from the location to the desired points. Where two lines intersect, this is the location of the point. By

using three instrument locations, a triangle of error is formed around each point. These methods are indicated in Figure 2.

A sample field and watercourse layout survey and map are illustrated in Figure 3. Points A and B are points of known location. The distance between these points has been taped. The plane table is set up over point A and the mapping sheet has been set up with the points A and B separated by the scaled length (usually $1' = 220'$). The alidade is aligned to sight from A to B and the dotted line rays are then made to the corners of the field (1, 2, 3, and 4), the centerline of the watercourse (5 and 6) and the boundaries of the next field (7 and 8), centerline of the bund.

The plane table is moved and set up over point B and oriented to point A, as shown in Figure 4. The points 1, 2, 3, 4, 5, 6, 7, and 8 are resighted and appropriate dotted line rays are drawn as illustrated. Once the intersecting rays have been obtained the field boundaries can be drawn, as shown, with solid lines. In a like manner, points C and D are chosen in the next field, as shown in Figure 4. The distances from B to C and C to D are taped and the procedure continues for mapping the entire area.

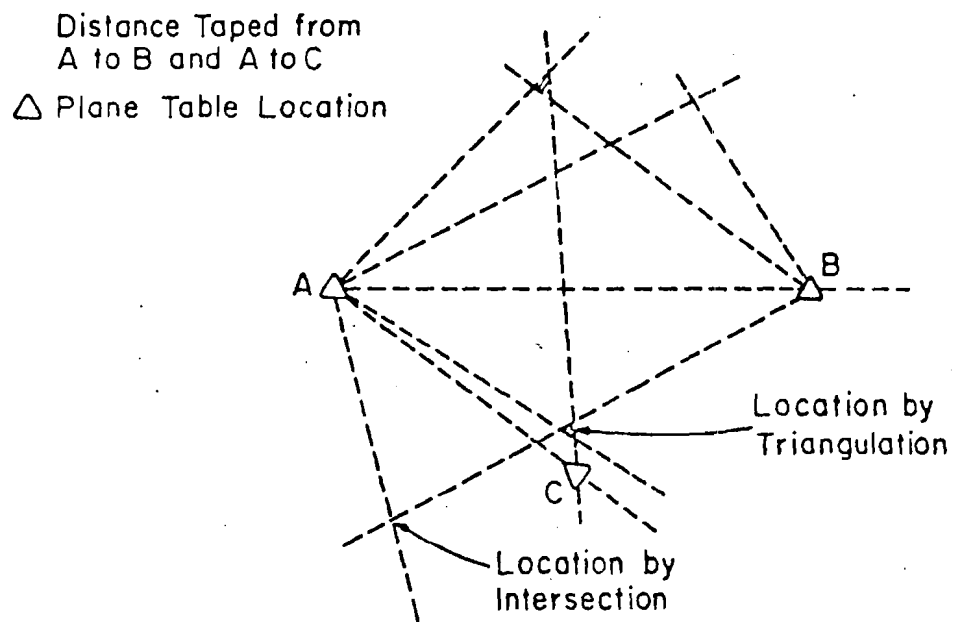

Figure 2. Illustration of the intersection and triangulation methods of locating points.

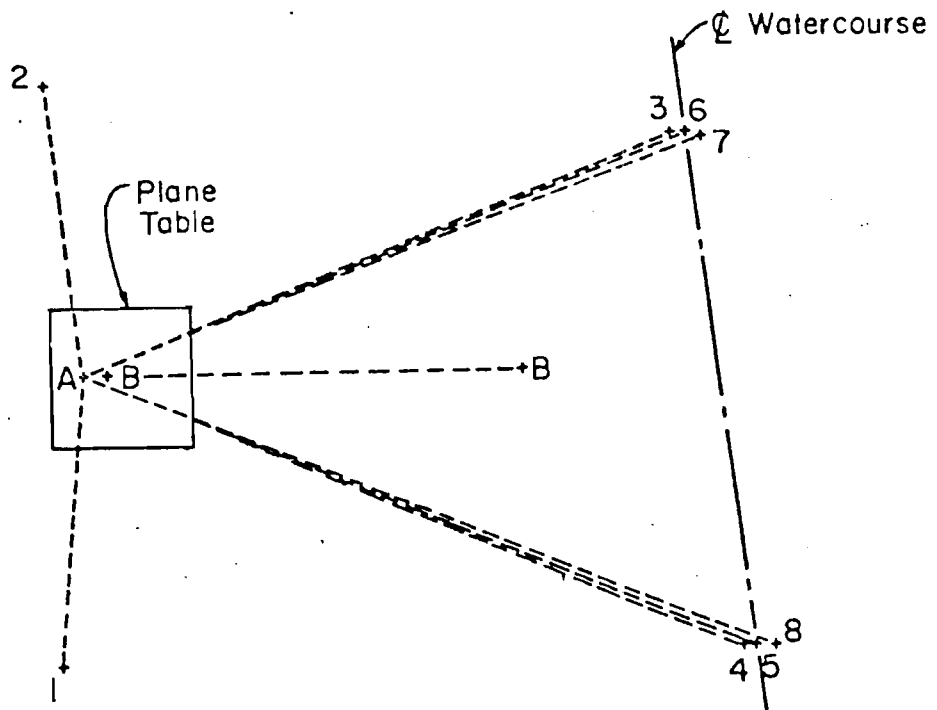

Figure 3. Step 1 in plane table mapping (plane table over point A).

EWUP

How to do it

Field Procedure



TOPOGRAPHIC MAPPING USING GRID METHOD AND LEVEL

by Wayne Clyma and Alan Early*

Maps are essential to the best farm planning. In addition, maps are frequently the basis for engineering design of farm layouts and soil and water conservation structures and facilities. Experience indicates a definite shortage of maps which provide adequate background for farm planning and engineering design (scale 1:5000 or less). Field technicians, no matter where, have encountered a need for adequate maps to assist in the application of engineering techniques.

TOPOGRAPHIC MAPS

A map which shows horizontal distances, horizontal angles, and elevations is called a topographic map. The addition of elevation to a map results in the map showing topography, or relief of the land surface. The contour map is the simplest method of showing elevation on an otherwise two-dimensional sheet of paper. A contour is an imaginary line of constant elevation on the surface of the earth. The shoreline of a lake is a contour frequently seen in nature as the waterline is a line of constant elevation. A contour line is a linear connecting points on the map which represents points on the surface of the ground having the same elevation. The elevation of the contour line is usually indicated by numbers on the line.

The following characteristics of contour lines are useful guides in drawing and interpreting maps:

1. Evenly spaced contours show a uniform slope.
2. The distance between contours indicates the steepness of the slope. Wide spacing denotes flat slopes: close spacing, steep slopes.

* This How-To-Do-It was taken from The Problem Identification Handbook (April 1, 1980). Developed by the CSU-Pakistan Water Management Project sponsored by U.S. Agency for International Development, Contract No. AID/TAC-1100.

3. Contours which increase in elevation represent hills. Those which decrease in elevation portray valleys. Contour elevations are shown at breaks in the contour to avoid confusion.
4. Irregular contours signify rough, rugged country.
5. Contour lines tend to parallel each other on uniform slopes.
6. Contours never meet except on a vertical surface such as a wall or cliff. They cannot cross except in the unusual case of an overhanging shelf. Knife-edge conditions are seldom found in natural formations.
7. Valleys are usually characterized by V-shaped contours, ridges by U-shaped contours.
8. The V's formed by contours crossing a stream point upstream.
9. The U's made by contours crossing a ridge line, point down the ridge.
10. All contour lines must close upon themselves either within or without the borders of the map.

METHODS OF MAPPING

There are three methods of making topographic maps for agricultural engineering surveying, they are:

1. Grid method
2. Angle and stadia method
3. Plane table and alidade method (telescope alidade with stadia hairs)

The particular method used depends upon several factors. These are:

1. The use of the man
2. The kind of equipment available
3. The kind of personnel available
4. The topography of the land to be mapped
5. The size of the area to be mapped

Another method of mapping in use, which has agricultural application, is aerial photography. The aerial photograph furnishes details of topography, unavailable in other methods of mapping. In addition, by the use of stereoscopes, contours can be added to the aerial photograph with a minimum of field surveying for horizontal and vertical control. Aerial photographs may, or may not, be available in the areas where work is to be done.

THE GRID METHOD

The grid method of topographic mapping has several advantages. It can be done with a farm level and a steel tape, equipment which are readily

available. It lends itself to topographic mapping of individual fields and farms where the ground surface is relatively flat. The amount of effort spent in the field doing the survey is about equal to the effort spent in the office preparing the map. The running of contour lines across very flat ground is difficult. Therefore, the taking of elevations at regularly spaced intervals should result in a better topographic map. The grid method is the most widely used method of surveying for land leveling, since the relocation of each point is simple. This relocation of each point is essential to checking elevations as the leveling progresses.

PROCEDURE FOR THE GRID METHOD OF MAPPING

Where possible, the area to be mapped should have two sides that intersect at right angles (90°) with each other. This is particularly applicable to the uniform layout of the kila-bundi pattern of Pakistan. If this is not possible, then the diagonals and all four sides of the field need to be measured, or if the fields are irregular in shape, a plane table survey of field boundaries is necessary before location of the grid points is possible. Two sides of the field can then be staked at regular intervals for the grid and the surveying done in the same manner as for two sides that intersect at 90 degrees. After a preliminary survey of the area to be mapped, two sides are selected to establish the grid. Each side is then staked with tall stakes at regular intervals. The length of the interval depends upon the use of the map. General topographic maps are frequently staked at 25 or 30 meter intervals. Maps for land leveling design and computations are usually staked at 10 to 15 meter intervals.

One side of the area is then numbered at each stake location from 0 to the end of the stakes. The other side is lettered at each stake location from A to the end of the stakes. The stakes used at each grid point should be a minimum of 1 meter high and 2 meters is preferred.

After the two sides have been staked, then two additional sides are staked. The stakes start at 1 and continue to the end of the lettered points. The other row starts at B and continues to the end of the numbered stakes. The rodman can then locate himself at any grid point by sighting along the four stakes that form the two lines that intersect at his particular grid point.

After the 4 rows of stakes have been established at the grid points, then the elevation of each grid point is established by profile leveling.

Each grid point is designated by the appropriate letter and number as shown in the sample notes in Figure 1. The survey is closed by returning to the BM after the elevation of each grid point has been determined. It is important that the arrangement of the grid be shown in the notes on the right side of the page. This will assure that the map is properly oriented when it is prepared in the office.

For watercourse survey purposes taping is not necessary. General watercourse surveys require the use of a one-acre grid. For this purpose the approximate location of the center of an acre can be obtained visually or by pacing, but without taping or staking the location. A portable turning point is merely used at this location to give a representative elevation for that acre. Surveying begins and ends at a bench mark determined in the initial bench mark survey of the watercourse area.

For the detailed survey of sample farmers' fields, a more intensive data collection scheme is required. Four elevation determinations per irrigation unit are required for this purpose. Each acre might possibly have 2 to 10 of these smallest irrigation units. The intensity thus increases to 8 to 40 shots on a per acre basis, depending on the number of banded units per acre.

MAP PREPARATION

The topographic map is prepared from the field notes. A map prepared from the field notes shown in Figure 1 is shown in Figure 2. For relatively flat areas, a contour interval of 0.25 meters should be used. For a more rolling topography 0.50 meter or 1.00 meter intervals can be used.

For watercourse mapping a contour interval of 0.25 feet is required for general use. For land leveling design a grid spacing of 50 feet is desirable on small leveling jobs and 100 feet is acceptable on large-scale leveling jobs. The required precision of leveling is ± 0.05 feet (0.10 maximum difference across the irrigated unit). Thus if topographic maps are to be used for land leveling design work the contour interval should be a maximum of 0.5 feet, with 0.25 feet the preferred interval.

Note that certain information is included on the topographic map. A title, location of the mapped area, survey personnel, date of the survey, scale, person preparing the map, date of map preparation, legend, north arrow, and important natural and manmade topographic features should always be included on the map.

TOPOGRAPHIC LEVELING

No.	BS	HI	FS	Elev.
BM ₁	1.20	101.20		100.00
A ₀			2.21	98.99
A ₁			2.47	98.73
A ₂			2.11	99.09
A ₃			1.38	99.82
B ₃			1.44	99.76
B ₂			1.86	99.34
B ₁			2.08	99.14
B ₀			2.21	98.99
C ₀			2.09	99.11
C ₁			2.00	99.20
C ₂			1.65	99.55
C ₃			1.25	99.95
C ₄			0.53	100.67
D ₄			0.53	100.67
D ₃			1.06	100.14
D ₂			1.27	99.93
D ₁			1.77	99.43
D ₀			1.85	99.35
E ₀			1.44	99.76
E ₁			1.04	100.16
E ₂			0.90	100.30
E ₃			0.60	100.60
E ₄			0.26	100.94
TP ₁	2.51	102.42	1.29	99.91
B ₄			1.14	101.28
A ₄			0.70	101.72
BM ₁			2.44	99.98
BS =	3.71	FS =	3.73	100.00

Cloudy, windy Tewolde W.
 Aug. 19, 1965 Hailu S.
 BM₁ - A point x, marked on
 the pole stand on the pole
 next to the bridge on the
 road to the Horticulture
 area about 4 meters from
 the road and 52 meters from
 the south west end of the
 bridge.

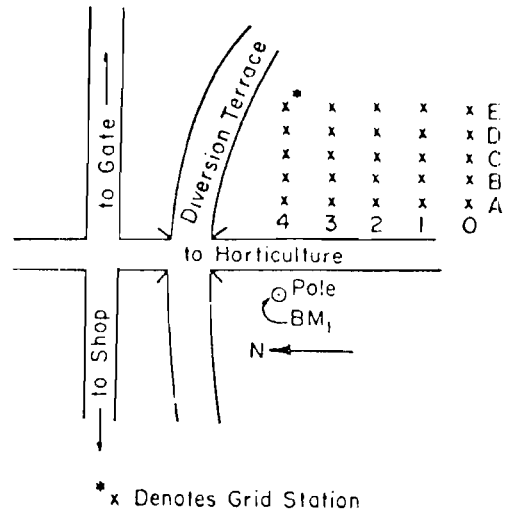

Error of closure = FS - BS
 = 3.73 - 3.71
 = 0.02 0.02 Check

Figure 1. Field notes for topographic map using grid method of mapping.

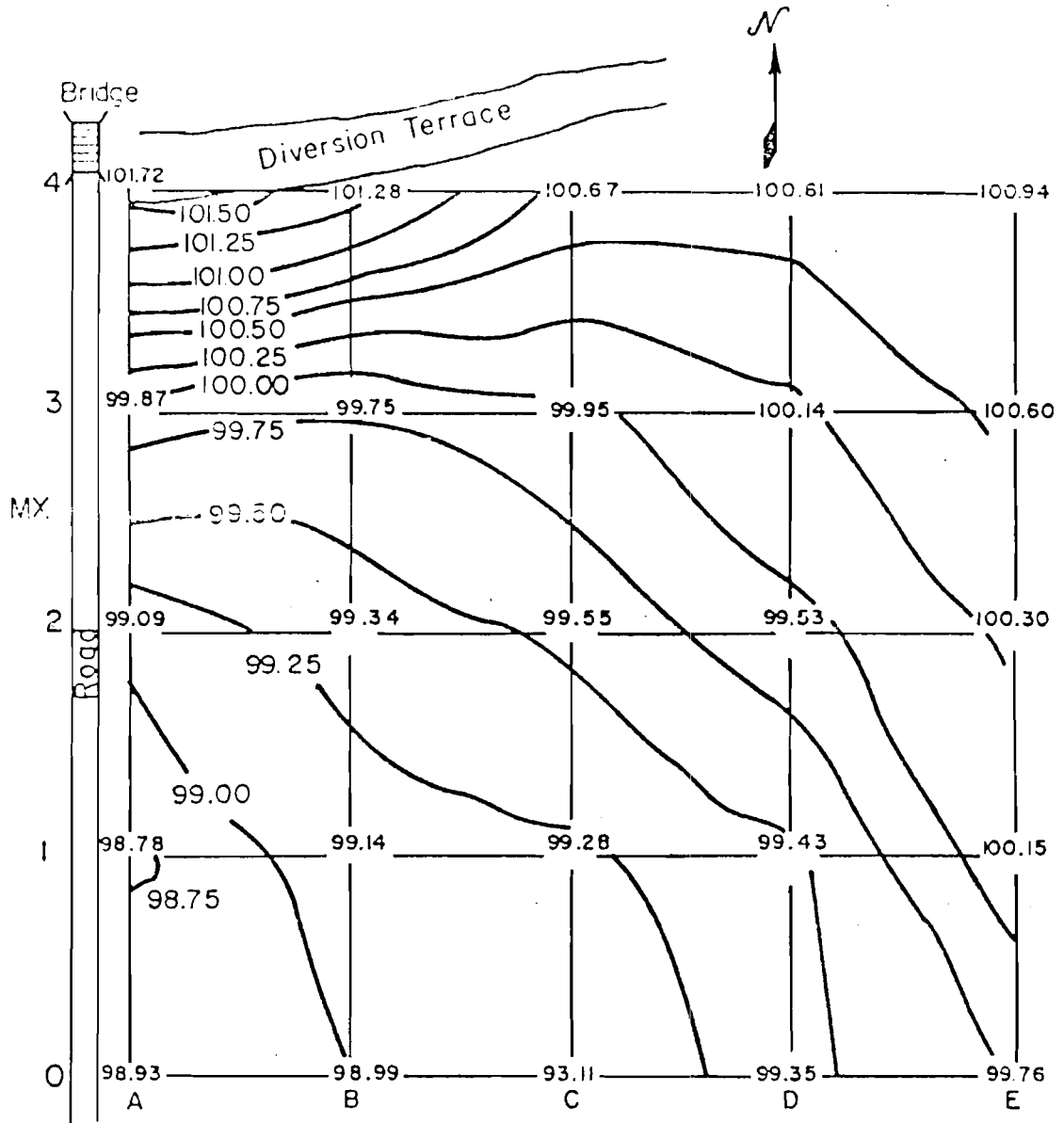

TOPOGRAPHIC MAP
 College Farm
 Surveyed by Tewelderbrhan W.M. & Hailu S.
 Date: August 19, 1965
 Scale: 1:750
 Plotted: by Hailu S.
 Date: August 23, 1965

Figure 2. Topographic map from field notes in Figure 1.

Maps are frequently prepared with one contour more heavily than the others. Notice in Figure 2 that the even meter contours, 99.00, 100.00 and 101.00 are more heavily accentuated. This is done to provide better contrast between the general relief and the detailed topography of the area.

The contours are entered on the map by placing a triangular scale or ruler between grid points of known elevation. The point of even numbered contour is proportioned between the two points, a procedure which assumes a uniform topography or slope in the vicinity.

EWUP

How to do it

Field Procedure



EVALUATION OF FURROW IRRIGATION SYSTEMS^{1/}
 by Thomas W. Ley and Wayne Clyma^{2/}

INTRODUCTION

Evaluation of the performance of furrow irrigation systems requires the collection and analysis of data relating to both the operation and management of the water application subsystem. The procedures suggested for the collection and analyses of data which follow can be used at two levels depending on the amount of detail desired. The less detailed approach provides satisfactory evaluation of system performance utilizing a suggested minimum number of analyses. The more detailed approach adds information on the operating aspects of the hydraulics of the system. Most often, the more detailed measurements are desired for an evaluation of some aspect of system design hydraulics. The less detailed approach provides fully the benefits of an evaluation of farmer practice. Discussion of the procedures for collecting and analyzing the more detailed types of data is provided in a later section. An equipment list and suggested data forms are provided later. The following subsections discuss the data to be collected, the chronological evaluation procedure and suggested analyses of the data for the evaluation of farmer practices.

REQUIRED DATA

Preliminary Data

There is a large amount of preliminary site data which should be collected and analyzed before the evaluation of an irrigation occurs.

^{1/}Prepared under the support of the U.S. Agency for International Development, Contracts AID/NE-C-1351 and AID/DSAN-C-0058. All reported opinions, conclusions or recommendations are those of the authors and not those of the funding agency of the U.S. Government.

^{2/}Research Associate and Associate Professor, respectively, Dept. of Agricultural and Chemical Engineering, Colorado State University, Fort Collins, Colorado.

These data include physical information of the site and information from the farmer concerning his irrigation system and its operation. A list of suggested questions to direct to the farmer in order to obtain information in each of the following categories is included in Appendix A. Other more site specific questions should arise from the farmer's answers to these general questions.

1. Farmer operation and management.--Understanding why or how a farmer does certain things in managing and operating the irrigation system is vital. Often this aspect of evaluating irrigation performance may be overlooked and incomplete knowledge of the irrigation system state results. Farmer management may be constraining the level of performance which can be attained. The general level of knowledge of the farmer concerning irrigation principles and practices is evaluated. Other information discussed later will aid in determining if system management can be improved.

2. Water supply.--The farmer will know the available water supply, source, delivery, frequency, etc. He may have only a general knowledge of the flow rate and quality. These should be measured during the course of an evaluation. On-farm conveyance losses may be a big problem. The farmer may or may not know. Measure the losses if necessary.

3. Crop characteristics.--The crops grown and the planting dates of each must be known. Available data in the literature on crop seasonal water requirements, rates and stages of growth, maximum potential rooting depths, time from planting to effective cover, etc. This information along with climate data is used to estimate crop water use through the irrigation season. The crop root zone should be measured at each irrigation for crops with expanding root systems. The measured root zone for a perennial crop (such as alfalfa) can often be assumed valid for the entire season unless a highly fluctuating water table is encountered. The crop root zone at each irrigation determines the available soil water reservoir at that time and is necessary to determine the soil water deficiency, the stress at the time of irrigation and performance parameters such as water application and water requirement efficiencies.

4. Physical characteristics.--Measure and record the field dimensions. Stakes should be driven into the ground at 25-m intervals along the length (adjust for size of field as necessary). Measure and record surface elevation at each stake (station) using a field rod and level. Plot

the surface profile (elevation vs. length). Measure and record furrow spacings at several locations in the field. Determine if the downstream boundary condition is ponded or free outflow. Determine where and how to measure furrow inflow and runoff.

5. Soil survey.--If available, obtain information on soils in the area (on the farm), such as maps and classifications from a local or regional office (e.g., USDA Soil Conservation Service or similar government agency). Such information is very useful and aids the design of data collection procedures. Soil types and textures are known and maps usually depict the variation of surface textures in a field. If this information is not available, a soil survey is necessary to determine the soil types and uniformity in the field being studied. Soil samples should be collected in a minimum of ten locations in the field (i.e., at five locations along the length and two along the width). Samples should be taken from a minimum of four depths within the expected root zone, i.e., every 30 cm in an expected 1.2 m root zone (adjust as necessary). These samples should be analyzed to determine soil types.

Once soil types and variations through the field are known the apparent specific gravity of the soil (bulk density) and the field capacity and wilting point of the soil must be determined. Garcia (1978) presents procedures for these measurements. Depending on the results of the soil survey the sample collection procedure is defined. For a field with uniform soils it is necessary to collect data on the above soil properties in a minimum of three locations in the field to obtain a good average. For a field with nonuniform soils the above soil properties must be determined for each major soil type. A minimum of three replication of samples is necessary to obtain an average. In all cases, it is necessary to sample with depth. See Appendix B for further discussion.

Accurate definition of the above soil properties is necessary. The time and effort necessary to achieve this are well worth it and will eliminate having to repeat any sampling. These data are most easily collected before the crop is planted. Some change of apparent specific gravity of the plow layer with time may be expected. Sampling plans for soil water content and infiltration tests will be functions of soil type and uniformity. The results of the soil survey should thus be available in advance of the initial irrigation evaluation.

If soil salinity/alkalinity is expected to be a problem (indicated by maps, previous surveys, information from the farmer), samples should be analyzed to determine the salinity/alkalinity. Such a problem may also indicate the presence of a high water table.

6. Water table.--The farmer should have general knowledge of water table conditions in the area. Soil survey results may indicate a high water table. If the water table is high or expected to fluctuate considerably (i.e., within the maximum potential root zone), it is desirable to monitor the ground water level through the irrigation season. This can be done with a series of grid of observation wells (EWUP, Vol. II, 1979).

A high water table can limit crop growth through water-logging. The groundwater quality can also seriously affect crop growth and should be measured.

Crop water use from the capillary fringe or the water table is possible. Estimates of crop consumptive use by evapotranspiration modeling techniques will not correspond with measured soil water deficits (by soil water content sampling) when the crop is using groundwater, assuming either method is yielding accurate results. This is significant if the water table rises during the season due to early overirrigation. Water table fluctuations due to overirrigation may also contribute to crop consumptive use and can affect root zone expansion.

On The Day Before Irrigation

Infiltration Data.--Blocked furrow infiltration tests should be conducted in at least four locations along the irrigated run when the field has a uniform soil. When nonuniform soils are present, a minimum of three replications of a test should be conducted on each soil type. There should be enough labor available so that each infiltrometer (Figure 1) is manned throughout the test. The tests should last not less than seven to eight hours, and in some cases, as long as the duration of irrigation. Garcia (1978) presents procedures for the assembly and operation of the infiltrometers. Infiltration tests should be conducted in furrows other than those in which advance and recession data will be collected, but must be in furrows which will be irrigated. Further discussion of considerations of where to sample and how often is included in Appendix B.

Preirrigation Soil Water Content Data.--Garcia (1978) presents procedures for the collection and analysis of soil samples for determination of soil water content by the gravimetric method. In furrow irrigation, it is difficult to determine average water contents in the soil profile since the entire soil surface is not covered with water during irrigation and there may be significant lateral movement of water in the soil. In all instances, samples should be taken from each of several layers of the measured or expected maximum rooting depth of the crop (i.e., for a 1.2 m root zone, sample each 30-cm layer, and in the top 30-cm layer, collect samples from each 15-cm increment). If the water table is higher or near the expected maximum rooting depth, samples should be collected to near the water table. Each individual sample should be 150 grams or more. A problem arises in determining where to sample at each location. When every furrow is irrigated, it is suggested that samples be taken from the bottom of the wet furrow and the middle of the furrow ridge (plant row) between furrows to get a representative average (Figure 2a). When every other furrow is irrigated, it is suggested to take samples from the bottom of the irrigated furrow, the middle of the furrow ridge (plant row), and from the bottom of the nonirrigated furrow, in order to get a representative average of the water content below the ground surface and between wet furrows (Figure 2b). For this case, an average water content for each layer sampled could be defined as:

$$P_{w,avg} = \frac{P_{w,1} + 2P_{w,2} + P_{w,3}}{4} \quad (1)$$

where $P_{w,avg}$ = average water content for the layer,
 $P_{w,1}$ = water content for the layer in area 1 (see Figure 2b),
 $P_{w,2}$ = water content for the layer in area 2 (see Figure 2b),
 $P_{w,3}$ = water content for the layer in area 3 (see Figure 2b).

It is pointed out that area 2 (Figure 2b) receives twice the weight of the others in computing the average, since this area does in fact occur twice in the soil volume being represented.

Soil sampling locations in the field are determined by the results of the soil survey. If soils in the field are found to be uniform a minimum of three sampling locations in different parts of the field (along the furrow) should be selected to obtain an average for the field. If soils are non-uniform or if nonuniform water applications are expected, a minimum of

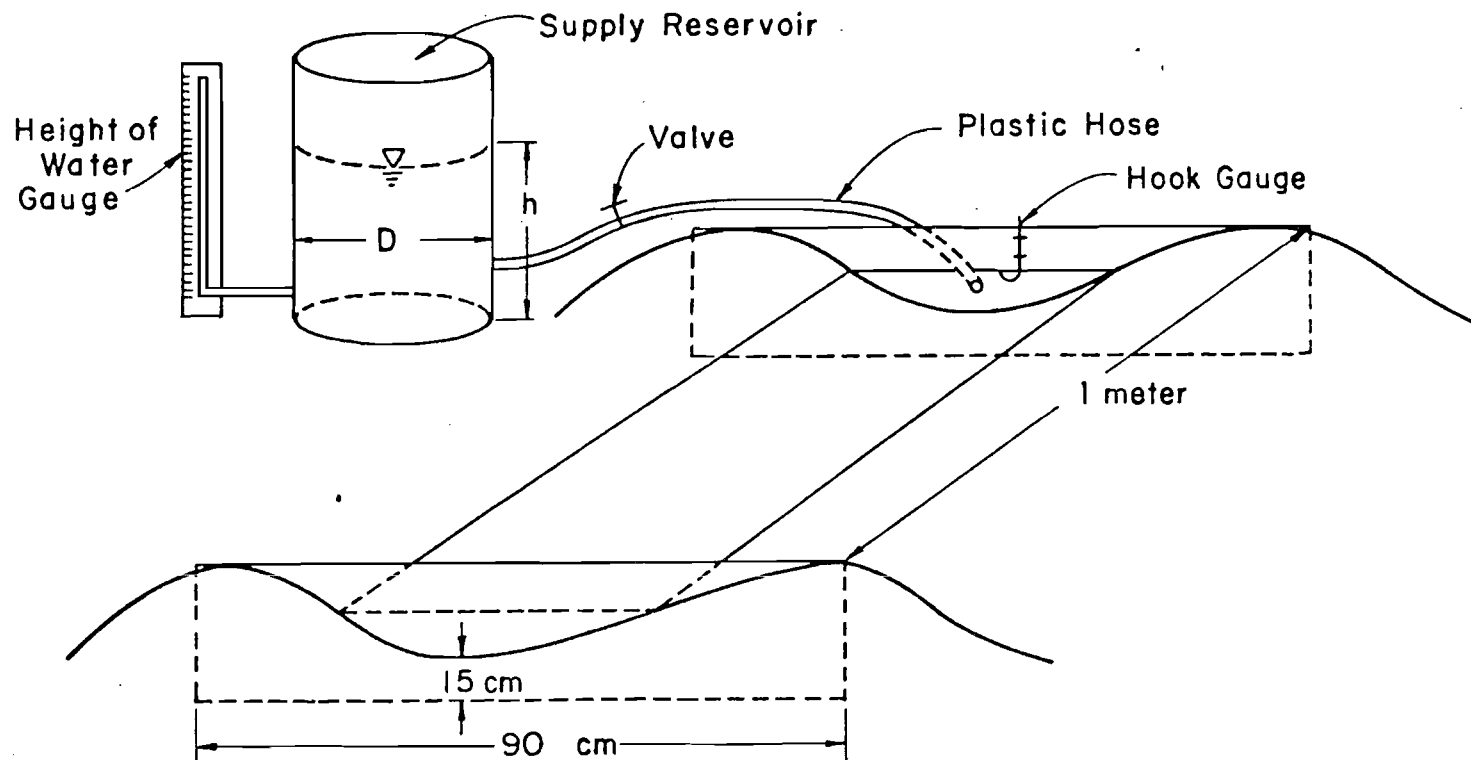

Figure 1. Blocked furrow infiltrometer.

three replications of samples in each representative area are necessary for computing an average. For instance, the distribution of applied water in many fields is nonuniform. A sampling scheme to delineate the differences along the length might be three replications of samples at the head, middle and tail ends of a field. See Appendix B for further discussion of the considerations of sampling plans, numbers of samples to collect, etc.

It is recommended that evaluation data (inflow/runoff, advance/recession, etc.) be collected on a minimum of three furrows. Flumes or other flow measuring devices should be installed at the head and tail ends of each furrow to be evaluated. Care must be taken to ensure that the flumes (if used) are level, have no leaks around them, and that the furrow sides are built up in the approach to the flume to prevent overtopping. Since the flume, being a critical depth flow measurement device requiring a loss of head, water in the approach section of the furrow will back up. This effect is more pronounced on smaller slopes than steeper ones. Flow measuring devices should be installed on the day before irrigation.

On the Day of Irrigation

The following data are taken on a minimum of three furrows as the irrigation progresses. The clock time when water is introduced to each furrow being studied should be recorded.

Advance Data.--Record the clock time at which the water arrives at each station (i.e., every 25 m) as the waterfront moves down the furrow.

Inflow Data.--Periodically record the clock time or elapsed time from the beginning of irrigation and reading for each inflow rate measuring device.

Runoff Data.--Record the clock time when water reaches the point (usually near end of field) where the runoff rate measuring devices are located. It is suggested that runoff data be collected at 30 sec, 1 min, 2 min, 4 min, 8 min, 15 min, 30 min and then every 1/2-hour from the time when runoff begins.

Recession Data.--Towards the end of irrigation, remove the flow measuring devices from the furrows. Record the clock time when water is shut off. Record the clock time at which water recedes from each station. The receding water edge is hard to define. Recession at a particular point is assumed to have occurred when approximately two-thirds of the furrow wetted perimeter is free of water. Very shallow flow conditions exist

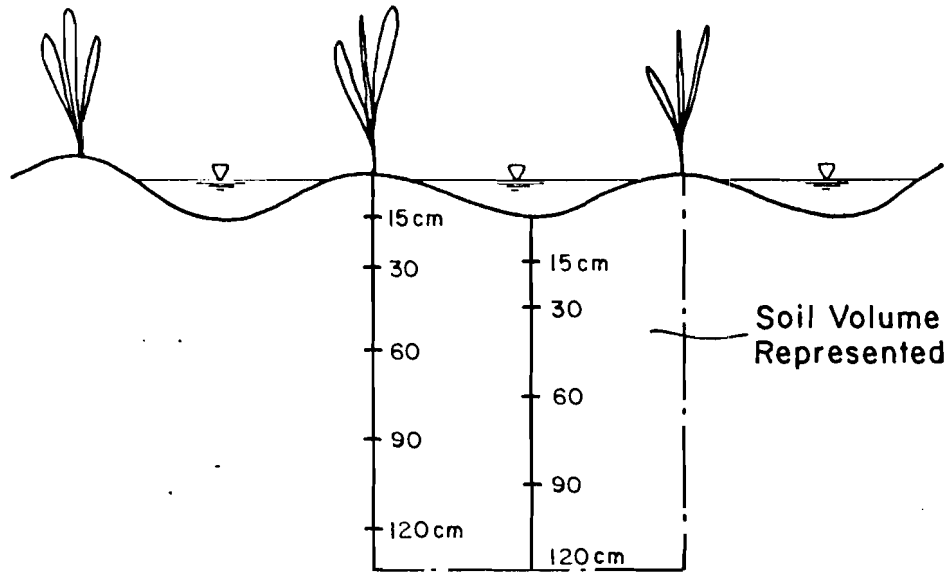

a) Suggested Sample Holes when Every Furrow is Irrigated

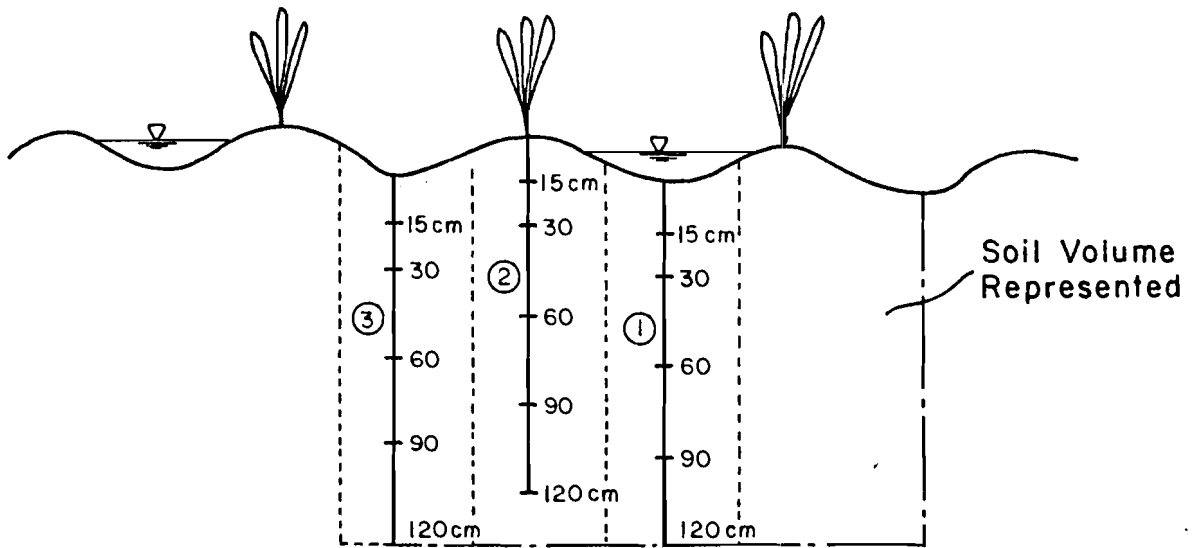

b) Suggested Sample Holes when Every other Furrow is Irrigated

Figure 2. Suggested soil water sampling locations across an irrigated furrow spacing.

during recession. Small puddles and ripples in the furrow bottom further compound the problem. Consistency is of prime importance when taking recession data.

All flow measuring devices should be checked during the irrigation for leaks and proper operating conditions. During the course of the evaluation any unusual factors or conditions should be noted. For instance, cracks in the soil significantly affect advance rate. Any erosion and sedimentation should be noted. Crop conditions (i.e., relative size, color, stand, wilting, etc.) throughout the section of the field being irrigated should be noted. Stunted growth may indicate salinity problems, poor infiltration rates (i.e., change in soil texture of plow pan layer which reduces infiltration) or other problems.

After Irrigation

Post-irrigation soil water content samples should be collected anywhere from 1-1/2 days to 3 days after irrigation. This depends on the soil type and the time required for the soil to drain to field capacity. Garcia (1978) presents a field procedure for estimating when (after wetting) a soil has drained to field capacity. The same collection procedures as previously discussed apply.

DISCUSSION AND RECOMMENDATIONS

It is important to convey to the farmer what will be done during the evaluation. Crop damage and soil disturbance should be minimized. Cooperation of the farmer in all aspects of the evaluation is a necessity. It is important that nothing the investigators do before or during the evaluation cause the farmer to deviate from his normal irrigation practices.

It is important that preliminary data collected early in the season be good data. A careful, coordinated, determined effort here will save much time and eliminate problems and headaches later in the season. For instance, the soil water content of a field before the initial irrigation of the season may generally be assumed as uniform. Much effort in careful soil sampling and in collection of more samples (to increase the precision with which the mean soil water content is estimated) is recommended. The establishment of this initial condition serves an important purpose. It is the starting point for a root zone soil water budget.

From this initial condition, water added to the root zone of the crop by precipitation (measured by rain gages set up in several locations at the

site) and by irrigation (measured by irrigation evaluations) is known. Crop use is estimated using climate data and crop stage and growth data in an accurate, calibrated evapotranspiration model. A root-zone soil water budget can thus be calculated through the season. Soil water content data collected at succeeding irrigations of the season are used as a check on the predicted soil water status when calibration of the ET model is necessary.

If there is a high water table in the area, crop use from the capillary fringe or the water table itself can be estimated. The difference between the calculated crop use and the measured soil water deficit (by sampling) during an irrigation interval is an estimate of the crop use from the water table during that interval. If there is no reason to believe that the crop is using water from a water table, then the computed difference indicates the accuracy of each method and possibly needed action to improve sampling or predictive techniques.

In some instances, collection of advance/recession data may not be necessary at each irrigation. For instance, a uniform application of water may be expected on a field with shorter lengths of run on a heavier soil. In this case, the distribution is assumed uniform and all that is required is the water on and water off to determine the water added to the soil. While this case may occur, it is advisable to collect advance and recession data when any nonuniformity of water application is suspected due to poor irrigation practices, nonuniform soils, nonuniform field slopes, etc. in order to know the distribution of applied water.

During the course of an actual irrigation evaluation, it is recommended that a partial evaluation of the data being collected be conducted. This is accomplished best by processing the data as it is collected in the field and interpreting the results. For instance, it is easy to evaluate inflow and runoff data and an obvious error is determined if the runoff is greater than the inflow. This check on data provides the investigator a means of eliminating wasted time and effort in the collection of erroneous data.

FIELD DATA ANALYSIS

Field data analysis provides a basis for understanding the performance of the irrigation system and how the system is being operated. The data may be analyzed through a number of procedures. Those presented here represent the minimum of analyses required to formulate an understanding of the system's performance resulting from a particular management scheme.

Infiltration Data.--The data collected during blocked furrow infiltration tests are generally of the form: total volume infiltrated per unit length vs. elapsed time. The data are plotted on log-log or rectangular grid paper. Garcia (1978) presents methods of analyzing the data such that an infiltration relationship of either of the following forms can be determined:

$$z = kt^a, \quad (2)$$

or

$$z = Kt^A + Ct \quad (3)$$

where z = cumulative volume infiltrated per unit length (L^3L^{-1}),

t = elapsed time (T),

C = steady-state or large-time infiltration rate ($L^3T^{-1}L^{-1}$),

k, a, K, A = empirical constants.

An infiltration function of either form (Eq. 2 or 3) should be found, and usually it is determined for the mean of the infiltration data collected at particular locations in a field. For instance, the mean would be determined for infiltration data on each major soil type or for each area where a sampling plan called for tests to be made.

Soil Water Content Data.--Procedures for determining the water content (dry weight basis) of each of the soil samples collected are presented by Garcia (1978). The depth of water in the soil profile is found using the following relationship:

$$d_m = \sum_{i=1}^n (P_{w,i} \times \gamma_{b,i} \times Y_i) \quad (4)$$

where d_m = water depth in the soil profile (L),

$P_{w,i}$ = water content (dry weight basis) of the i th layer of the profile (MM^{-1}),

$\gamma_{b,i}$ = soil bulk density in the i th layer of the profile [$ML^{-3}(ML^{-3})^{-1}$],

Y_i = thickness of the i th layer (L).

n = number of root zone layers sampled.

The preirrigation water depths at each sampling location (i.e., position in the field) are averaged and compared to the water depth when the soil is at field capacity. This gives an estimate of the amount of water which needs to be applied during irrigation to bring the root zone to field capacity. This method for determining the soil water deficit at irrigation time is

subject to the large degree of variability observed in soil water content sampling studies, and may give unreliable results. When reliable crop data and, climate data are available, another estimate of the soil water deficit can be obtained through the use of an evapotranspiration modeling procedure and soil water budgeting as discussed earlier.

Pre and postirrigation water depths can be compared to obtain an estimate of the depth of water infiltrated (assuming there is no deep percolation of water past the lowest sampling depth) at each of the sampling locations. This is, of course, subject to the comment made previously concerning the reliability of soil sampling to determine water contents. The temporal and spatial variability in soil properties can be magnitudes and even orders of magnitude in just a small area of a field. Thus, the limitation on the reliability of results is imposed.

Advance/Recession Data.--Normally, these data are plotted on a rectangular grid with time as the ordinate and distance along the furrow as the abscissa (Figure 3). The difference in time between the two curves is the infiltration opportunity time. The infiltration opportunity time at each station along the field should be determined. Often, the surface elevations are also plotted on the same sheet. Nonuniformity of slope along the run will usually show up in the advance and recession curves. A plot of the surface profile may often be very useful in helping to explain variations in advance and recession rates.

Inflow/Runoff Data.--The inflow and runoff data should be plotted vs. time (with inflow and runoff rates as the ordinates and time as the abscissa) on the same rectangular grid. These are the inflow and runoff hydrographs. The inflow hydrograph is plotted up to the time of shut off. Graphical integration of the area under this curve represents the volume of water applied, W_a (L^3). The runoff hydrograph is also plotted up to the time of shutoff. After shutoff, the runoff rate is assumed to decrease linearly from the runoff rate at the time of shutoff to zero at the end of recession. Graphical integration of the entire area under this curve represents the total runoff volume, W_u (L^3). The difference between the volume of applied water and volume of runoff, as determined by this method, is the volume of water remaining in the field, or the total volume infiltrated during the irrigation, i.e.,

$$W_i = W_a - W_u \quad (5)$$

where W_i = total volume infiltrated (L^3).

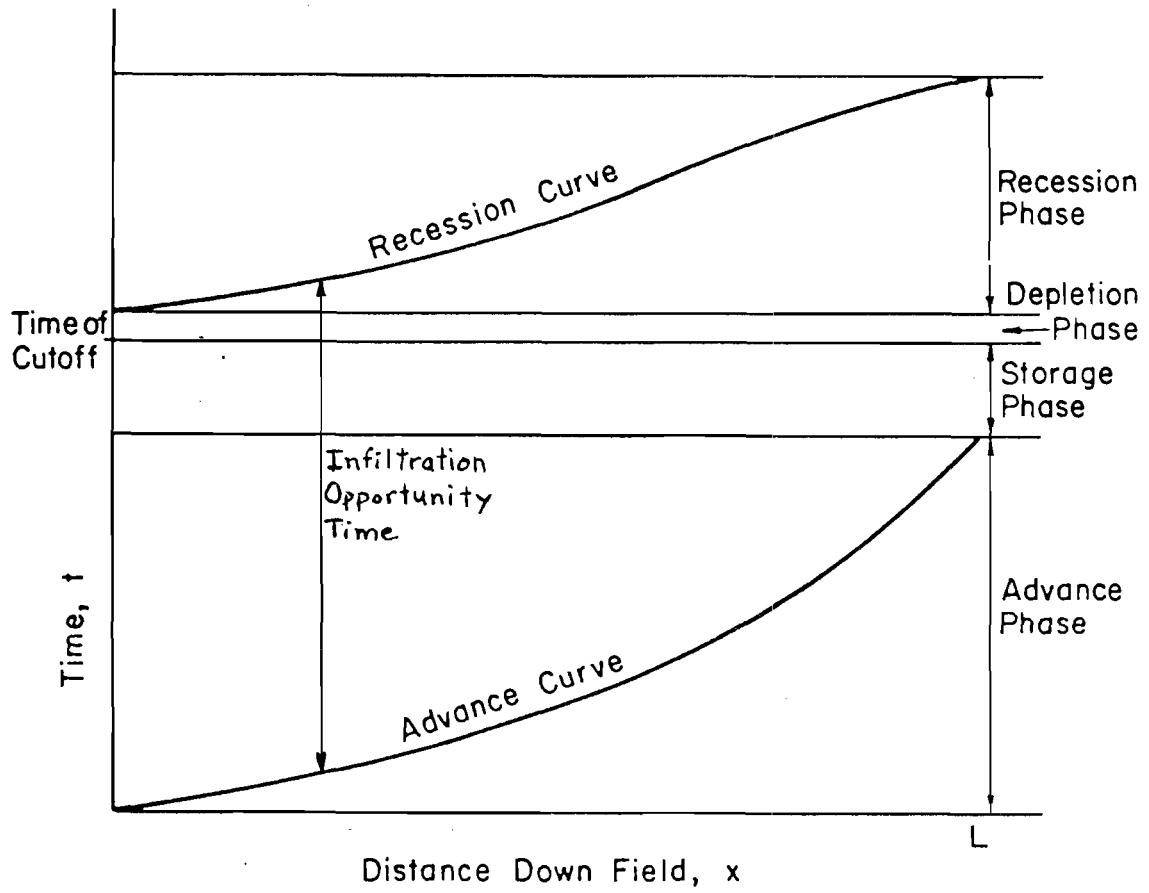

Figure 3. Simplified representation of advance and recession curves and phases of irrigation.

The inflow-runoff method is assumed to be the most accurate for determining the total volume of infiltration. This is because it gives the average infiltration for the entire furrow length (as opposed to "point" type measurements from infiltration tests or soil water data), and because flow rates can usually be measured more accurately than infiltration or soil water content.

Subsurface Distribution of Applied Water.--The subsurface distribution of applied water in furrow irrigation can be determined when the following information is known.

1. A representative infiltration function(s) as determined above.
2. Infiltration opportunity times along the irrigated run, i.e., advance and recession times at points along the run.

Upon construction of the subsurface profile, it is possible to characterize the performance of a particular irrigation. However, before irrigation performance parameters are defined it is necessary to define several related quantities upon which they depend.

Figure 4 represents an idealized profile of infiltrated water as a result of a furrow irrigation. The distance AB is the field length, and the line DFG is the boundary of the infiltrated water. If the downstream boundary condition is one of free outfall, then runoff water from the field can be assumed to extend to the imaginary field length C, and to infiltrate according to the profile CD. The water requirement depth at the time of irrigation is assumed uniform along the field length and is represented by line EFH. With these concepts in mind the following quantities with appropriate units shown in Figure 4 are defined.

1. Total volume of applied water, W_a (area ACDGA). This is the total volume of water introduced per furrow.

2. Total volume of water required in the root zone to reach field capacity, W_r (area ABEHA). This is the volumetric soil water deficit.

3. Total volume of water stored in the root zone, W_{rz} (area ABDFHA). This volume of water is dependent upon the field capacity of the soil and the available storage at the time of irrigation. The total volume of water available for plant use after the irrigation and drainage period equals the difference between the field capacity (FC) and the permanent wilting point (PWP) of the soil, assuming the root zone is completely filled from the

permanent wilting point to field capacity during irrigation [i.e., the total available water expressed as a depth, $TAW = (FC - PWP) \times (\text{bulk density of the soil}) \times (\text{rooting depth})$].

4. Total volume of deep percolation, W_p (area FGHF). The volume of water which infiltrates past the lower boundary of the root zone. W_p may equal zero in some cases.

5. Total volume of tailwater or runoff, W_u (area BCDB). The volume of water which runs off the end of the field if free outfall conditions exist.

6. Total volume of root zone deficit after irrigation, W_{df} (area DEFD). W_{df} equals zero if the root zone is completely filled.

The infiltration relationship(s) as determined from infiltration tests and the infiltration opportunity times from advance/recession data are used to plot the subsurface distribution. The total infiltrated volume as predicted by the infiltration function(s) should be determined from this plot. Comparison of this value with that determined by the inflow/runoff hydrograph analysis is a check on the adequacy of the infiltration function(s) in predicting the total infiltrated volume. If there is significant deviation, the multiplicative constants of the infiltration function(s) should be adjusted by a trial and error volume balance procedure until the two values coincide. Once this is finished, the subsurface distribution, as predicted by the "adjusted" infiltration function(s), is plotted. The soil water deficit as estimated through soil water content analyses or evapotranspiration studies is also plotted on the same sheet.

Efficiency and Performance Parameters.--Graphical integration of each of the representative areas of the subsurface distribution is used to find each of the volumes as previously discussed. Values of volume applied, volume infiltrated and volume of runoff as determined by both the inflow/runoff analyses and by the subsurface distribution should correspond (assuming the infiltration function used to construct the subsurface profile is representative, i.e., yields good prediction of total infiltration water volume).

Four irrigation performance parameters are defined as follows:

1. Water application efficiency, E_a , is the percent of the amount of water applied which is stored in the root zone for future use.

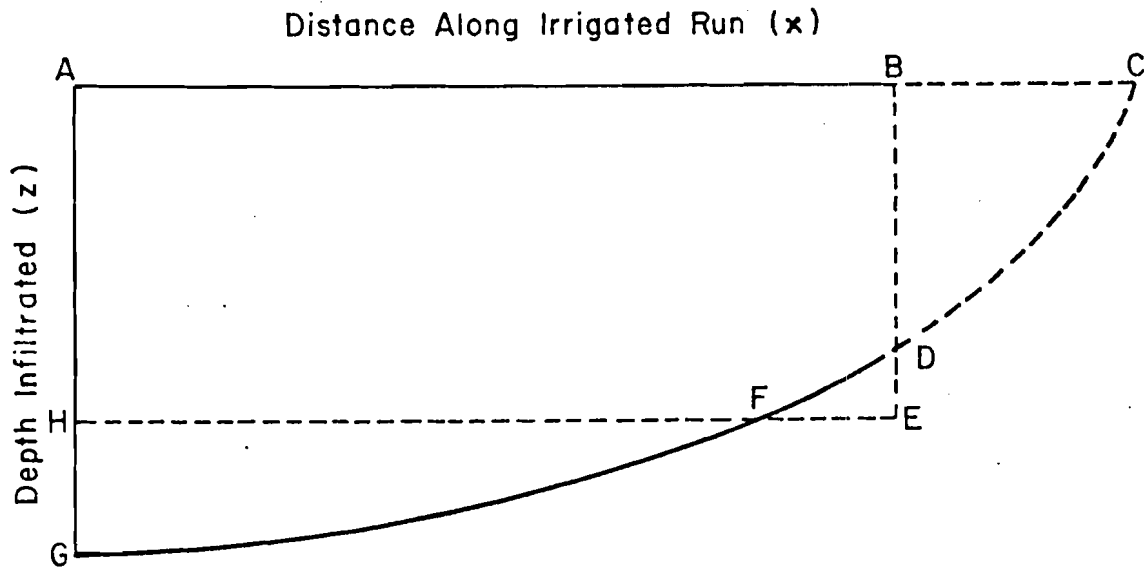

AB	length of furrow (L)
ACDGA	total volume of applied water per furrow, $W_a(L^3)$
ABEHA	total volume of requirement per furrow, $W_r(L^3)$
ABDFHA	total volume of actual root zone storage per furrow, $W_{rz}(L^3)$
FGHF	total volume of deep percolation per furrow, $W_p(L^3)$
BCDB	total volume of runoff water per furrow, $W_u(L^3)$
DEFD	total volume of root zone deficit after irrigation per furrow, $W_{df}(L^3)$

Figure 4. Idealized subsurface profile of applied water in furrow irrigation.

$$E_a = \frac{W_{rz}}{W_a} \cdot 100 \quad (6)$$

where

$$W_{rz} = W_i - W_p \quad (7a)$$

$$= W_r - W_{df} \quad (7b)$$

2. Water requirement efficiency, E_r , indicates the percent of the amount of water required to refill the root zone which is supplied by an irrigation.

$$E_r = \frac{W_{rz}}{W_r} \cdot 100 \quad (8)$$

3. Runoff (or tailwater) ratio, R_t , represents the fraction of the total amount applied which is lost as runoff from the end of the field.

$$R_t = \frac{W_u}{W_a} \quad (9)$$

4. Deep percolation ratio, R_p , represents the fraction of the total amount applied which is lost as deep percolation past the bottom of the root zone.

$$R_p = \frac{W_p}{W_a} \quad (10)$$

The sum of the deep percolation ratio, the runoff ratio and the water application efficiency (expressed as a fraction) is unity. Each of the above volumes can be treated as average depths when divided by the product of furrow length and irrigated furrow spacing.

EXAMPLE SYSTEM EVALUATION

The following discussion presents the results of an evaluation of a furrowed irrigation system using the procedures just discussed. A design of this field was formulated using the SCS furrow irrigation design procedure (USDA, 1978 draft). The results of this design are presented in a separate analysis of the design procedure (Ley and Clyma, 1980). Thus, it is possible to compare the current system operation and performance with the suggested design operation and performance. Ultimately, this allows for determination of possible system redesign and management changes such that improved system performance results. Recommended design parameters are repeated here for the reader's convenience.

$$Q = 0.57 - 0.76 \text{ lps/furrow (9-12 gpm/furrow)}$$

$$T_1 = 720 \text{ min}$$

$$\text{irrigated furrow spacing} = 1.12 \text{ m (3.67 ft)}$$

$$\text{design depth} = 61 \text{ mm (2.4 in.)}$$

The crop irrigated was sugar beets planted on a 0.56 m (1.84 ft) row spacing. Pre and postirrigation soil water content samples were collected, however, analysis has proven them to be inadequate. At any rate, an average evapotranspiration rate for sugar beets was determined to be near 6 mm/day (0.24 in./day) in the general area. The elapsed time from the previous irrigation (when the root zone was last completely filled) to the time of the irrigation being evaluated was 12 days. The soil water deficit was thus estimated to be approximately 72 mm (2.8 in.).

The farmer was irrigating the furrows from a concrete-lined head ditch using 1 1/4-in. siphon tubes. Every other furrow was being irrigated so the irrigated furrow spacing was 1.12 m. The average furrow grade is 0.0098 m/m. The furrow length is 365 m. Inflow and runoff measurements were taken at the head of the furrow and at $x = 350$ m, respectively. Soils were found to be uniform already, although there was some variation in texture with depth.

Five blocked furrow infiltration tests were conducted the day before irrigation at five locations along the length of run. The data, reduced to the form of volume infiltrated per unit length vs. time, are plotted in Figure 5. The mean infiltrated volume per unit length vs. time was found and is also plotted in Figure 5. A least squares regression procedure, outlined in Garcia (1978), was used to determine an empirical infiltration function of the form of Eq. (3) for the mean:

$$z = 2369.4 t^{0.37} + 70 t \quad (11)$$

where z = cumulative volume infiltrated (cm^3/m),

t = time (min).

This function is also plotted in Figure 5.

Advance and recession data and surface elevation data are plotted in Figure 6. Infiltration opportunity times at stations along the furrow are included. The time of advance to the runoff measuring device ($x = 350$ m) was 180 min. The plot of the surface profile slope (Figure 6) indicates the uniformity of slope is acceptable.

Normally, the farmer operates using a 12-hr inflow or set time. For this particular irrigation, however, a power failure caused pump shutdown and interrupted the irrigation. The inflow time over which measurements were taken was 7.5 hr. Inflow and runoff data for this time duration are plotted in Figure 7. Graphical integration of the area enclosed by each of these curves resulted in the following volumes:

$$\begin{aligned} \text{Total volume applied, } W_a &= 22.86 \text{ m}^3 \\ \text{Total runoff volume, } W_u &= 6.68 \text{ m}^3 \\ \text{Total infiltrated volume, } W_i &= W_a - W_u \\ &= 16.18 \text{ m}^3 \end{aligned}$$

An average infiltrated depth can be found by dividing by the furrow length and irrigated furrow spacing. In this case, a furrow length of 350 m is used since this is the distance over which infiltration occurred. The average infiltrated depth is:

$$\frac{16.18 \text{ m}^3}{(350 \text{ m})(1.12 \text{ m})} \left(\frac{1000 \text{ mm}}{\text{m}} \right) = 41.3 \text{ mm}$$

Infiltration opportunity times (from Figure 7) are used in Equation (11) to plot the subsurface distribution (see Figure 8). The ordinate in Figure 8 is actually an average infiltration depth in cm which is obtained by converting values obtained in Equation (11) from cm^3/m to m^3/m , then by dividing by the irrigated furrow spacing (m) and multiplying by 100 to obtain cm. Graphical integration of the area enclosed by this curve results in an estimate of total volume infiltrated per unit width as predicted by the blocked furrow infiltration function (Equation 11). This estimate is:

$$W_i')_{\text{pred.}} = 15.19 \text{ m}^3/\text{m of width}$$

where $W_i')_{\text{pred.}} = \text{estimated total volume infiltrated per unit width}$
 $(\text{L}^3\text{L}^{-1}).$

Multiplying by the furrow spacing (1.12 m) yields an estimate of the total volume infiltrated. Hence,

$$\begin{aligned} W_i)_{\text{pred.}} &= W_i')_{\text{pred.}} \times 1.12 \\ &= (15.19)(1.12) \\ &= 17.02 \text{ m}^3 \end{aligned}$$

where $W_i)_{\text{pred.}} = \text{estimate of total infiltrated volume } (\text{L}^3).$

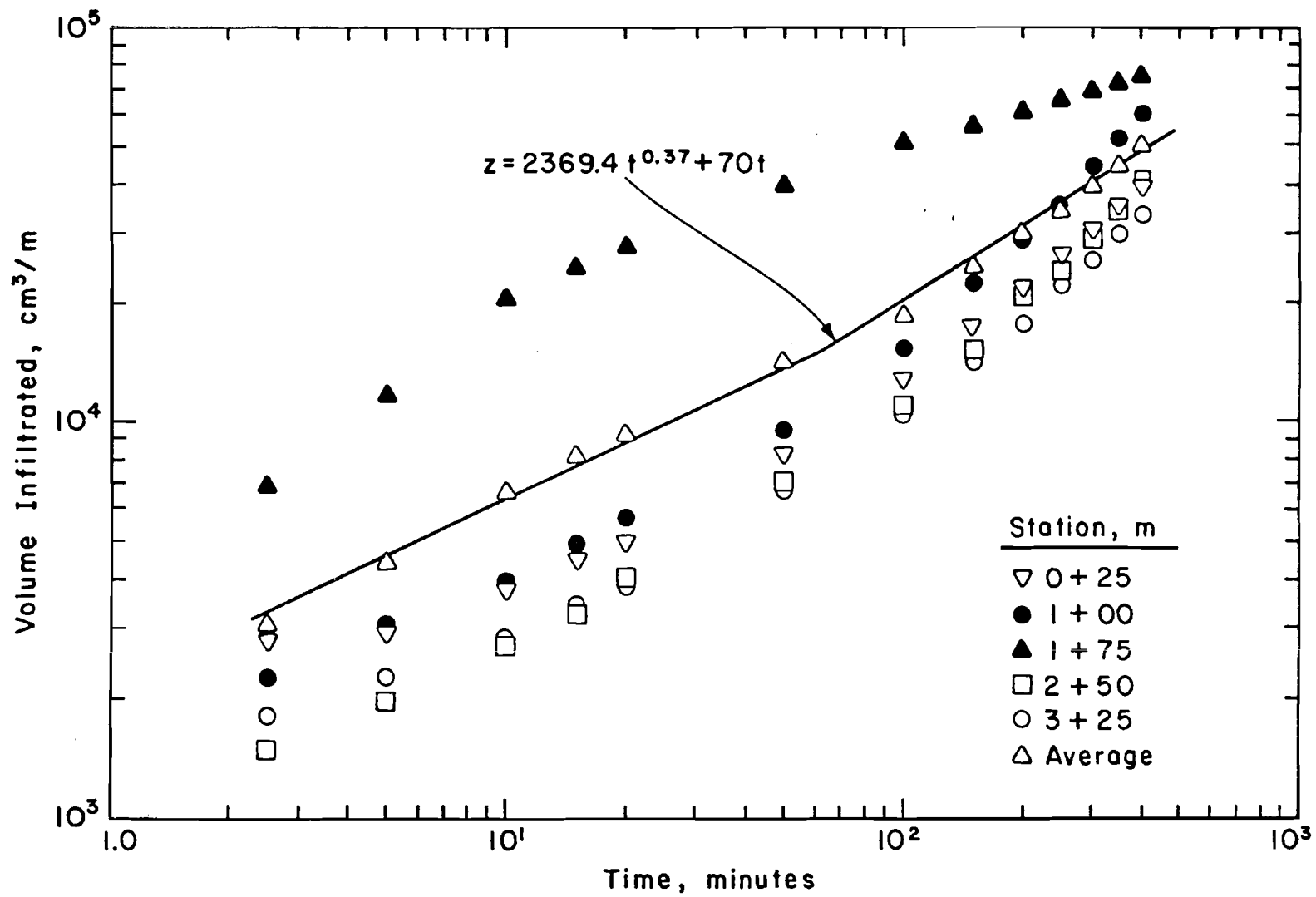

Figure 5. Blocked furrow infiltration test data.

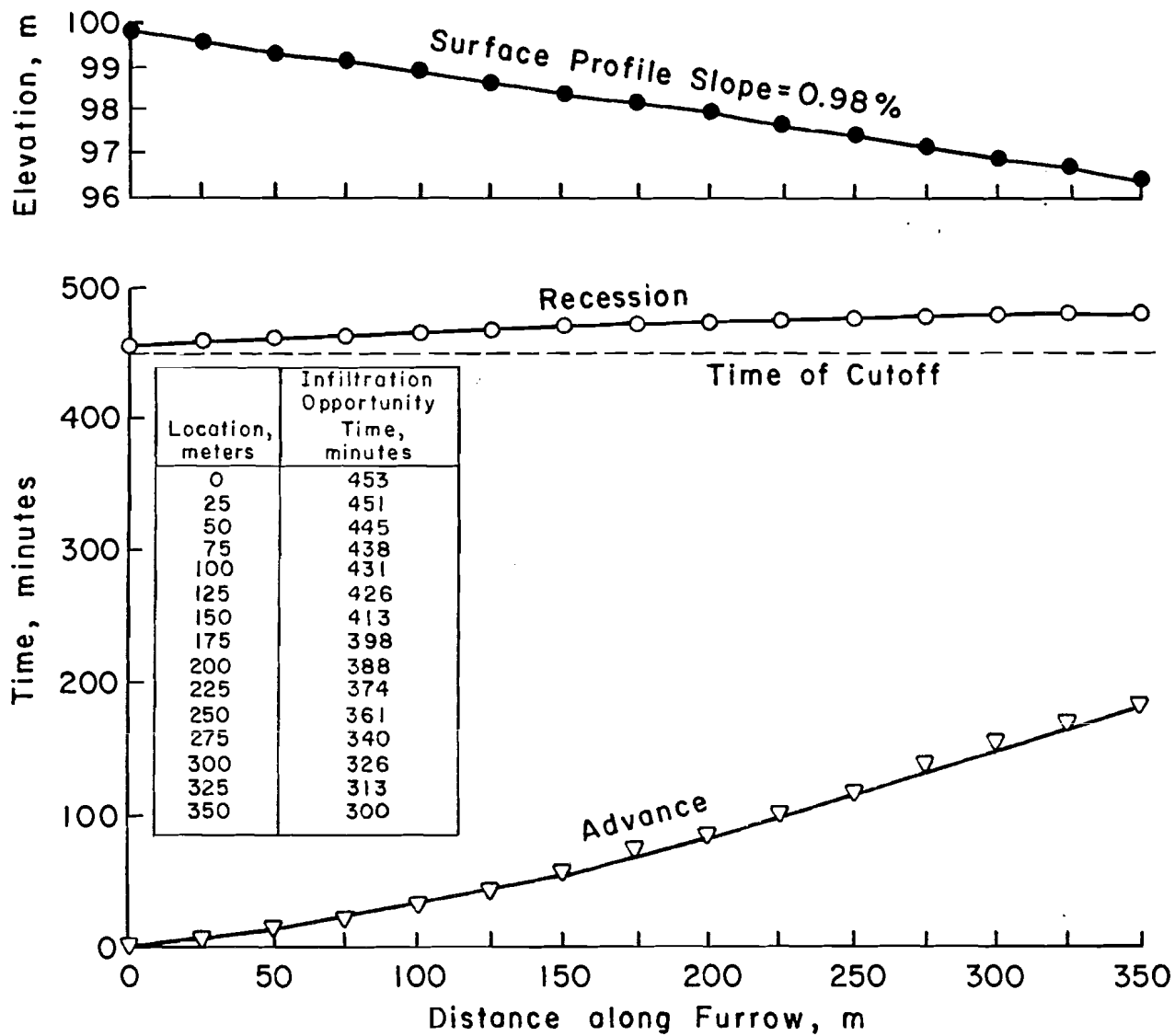

Figure 6. Advance/recession curves, surface profile slope and infiltration opportunity times.

An estimate of the average infiltrated depth as predicted by the blocked furrow infiltration function is:

$$\frac{17.02 \text{ m}^3}{(350 \text{ m})(1.12 \text{ m})} \left(\frac{1000 \text{ mm}}{\text{m}}\right) = 43.4 \text{ mm}$$

Comparison of the prediction of total infiltrated volume as obtained using the blocked furrow infiltration function with the value obtained by inflow/runoff hydrograph analysis shows the following deviation:

$$\left(\frac{17.02 - 16.18}{16.18}\right) 100 = + 5.2\%$$

This deviation is acceptable, considering the accuracy with which data can be collected in the field. Had the deviation been unacceptable (i.e., greater than 10 - 15 percent), then adjustment of the multiplicative constants in the infiltration function would have been necessary (by a volume balance trial and error procedure or graphical procedure, see example border irrigation evaluation by Ley and Clyma, 1980) until the deviation was within an acceptable range.

Results.--Each of the volumes associated with performance parameters can be determined with the results of the inflow/runoff hydrograph analysis and the subsurface distribution plot. For this case, the inflow/runoff hydrograph results are used. The volumes are as follows:

$$\begin{aligned} \text{Total volume applied, } W_a &= 22.86 \text{ m}^3 \\ \text{Total runoff volume, } W_u &= 6.68 \text{ m}^3 \\ \text{Total volume infiltrated, } W_i &= 16.18 \text{ m}^3 \\ \text{Total volume required, } W_r &= (72 \text{ mm}) \left(\frac{1 \text{ m}}{1000 \text{ mm}}\right)(350 \text{ m})(1.12 \text{ m}) \\ &= 28.22 \text{ m}^3 \\ \text{Total volume stored, } W_{rZ} &= 16.18 \text{ m}^3 \\ \text{Total volume deep percolated, } W_p &= 0.0 \text{ m}^3 \\ \text{Total deficit volume, } W_{df} &= 28.22 - 16.18 \\ &= 12.04 \text{ m}^3 \end{aligned}$$

Each volume can be converted to an average depth by dividing by the product of furrow length and irrigated furrow spacing. The performance parameters for this irrigation are determined using Equations (6) through (10).

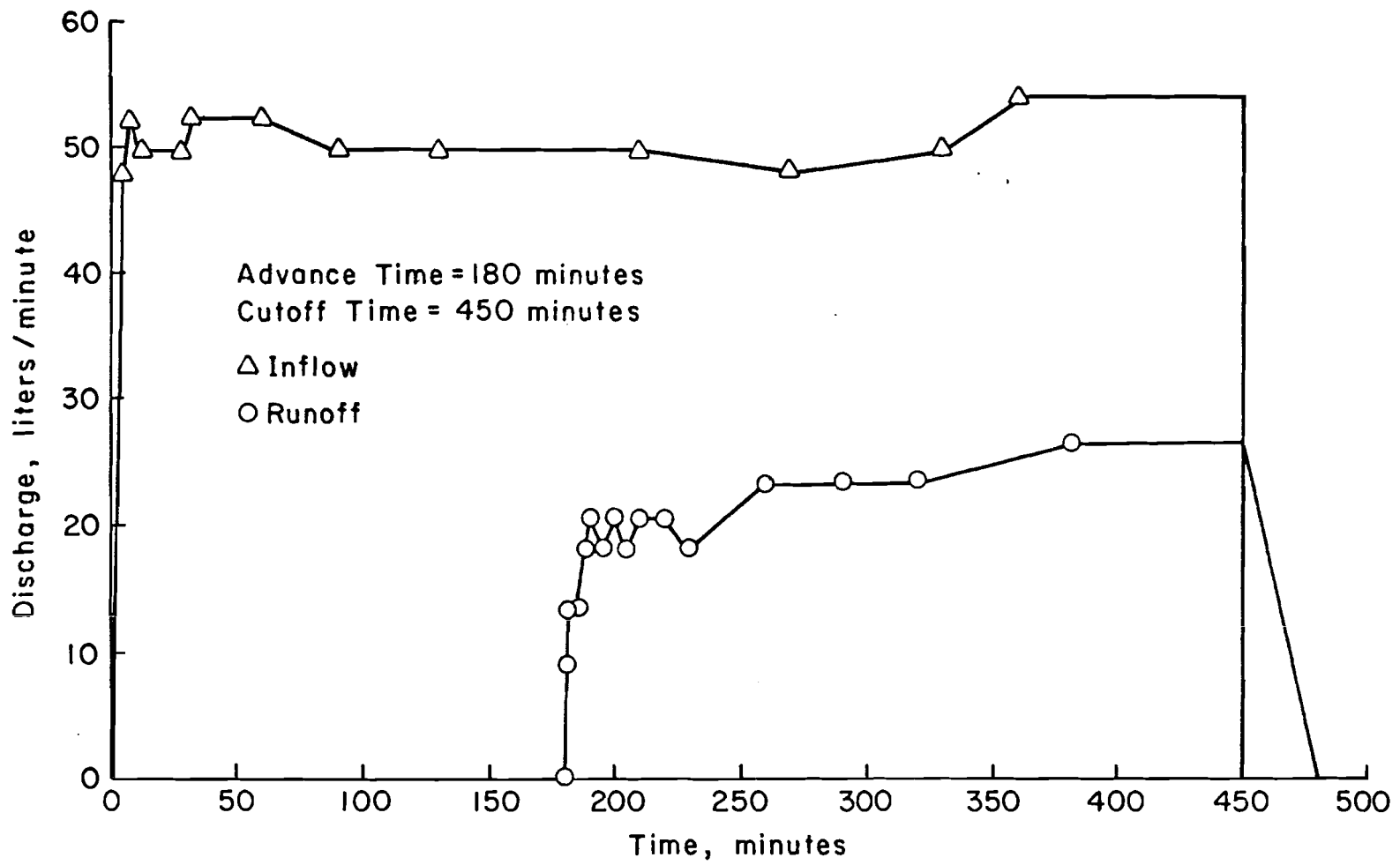

Figure 7. Inflow and runoff hydrographs.

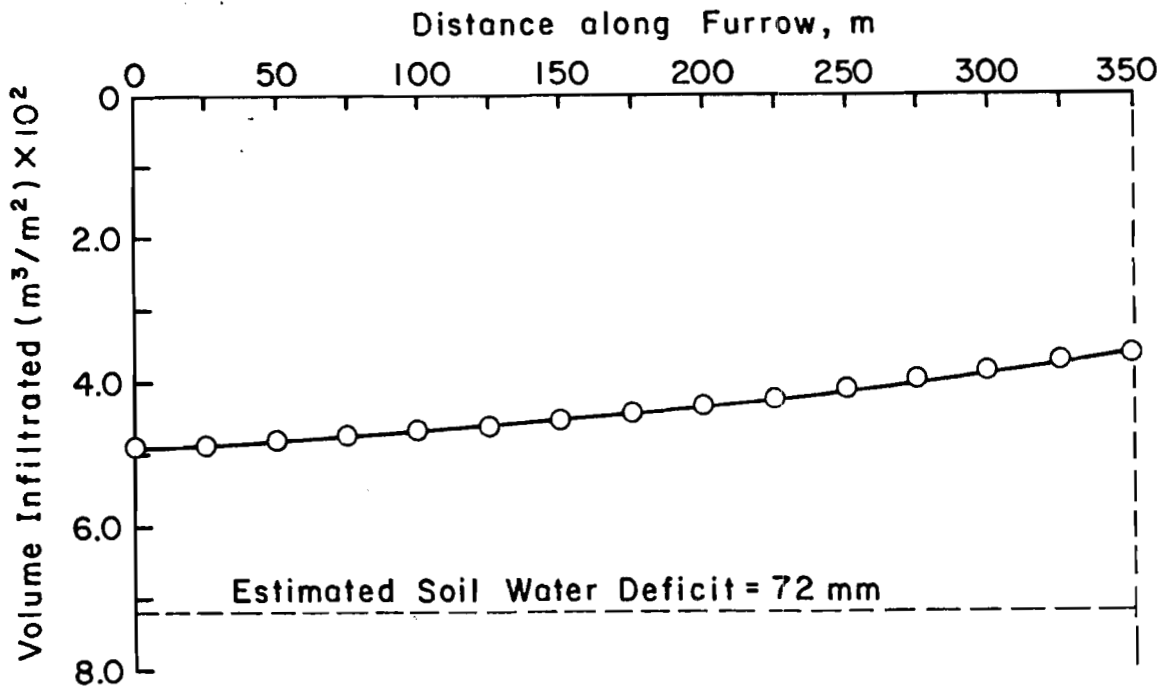

Figure 8. Subsurface distribution of applied water estimated from blocked furrow infiltration function, $z = 2369.4t^{0.37} + 70.0t$ (z - cm^3/m , t -min).

$$\text{Water application efficiency, } E_a = \frac{W_{rz}}{W_a} \cdot 100 \quad (6)$$

$$= \frac{16.18}{22.86} \cdot 100$$

$$= 70.8\%$$

$$\text{Water requirement efficiency, } E_r = \frac{W_{rz}}{W_r} \cdot 100 \quad (8)$$

$$= \frac{16.18}{28.22} \cdot 100$$

$$= 57.3\%$$

$$\text{Tailwater ratio, } R_t = \frac{W_u}{W_a} \quad (9)$$

$$= \frac{6.68}{22.86}$$

$$= 0.292$$

$$\text{Deep percolation ratio, } R_p = \frac{W_p}{W_a} \quad (10)$$

$$= \frac{0.0}{22.86}$$

$$= 0.0$$

Since the irrigation was interrupted by a power failure, it is not possible to compare the design with the results of this evaluation. However, it is known that the farmer normally uses a 12-hr set time and that he makes no adjustment to the furrow inflow rate once the siphon tubes are set. Hence, referring again to Figure 7, it is possible to estimate what the volumes for a 12-hr inflow time would have been. This is done by extrapolating both the inflow and runoff curves out to 720 minutes at a discharge rate equal to their averages for the last half of the 450 minute irrigation. Changes will occur in W_a , W_u , W_i , W_{rz} and possibly W_p . Estimates of what the volumes and performance parameters for the 12-hr set might have been are as follows:

$$W_a = 36.40 \text{ m}^3$$

$$W_u = 13.32 \text{ m}^3$$

$$W_i = 23.08 \text{ m}^3$$

$$W_{rz} = 23.08 \text{ m}^3$$

$$W_p = 0.0 \text{ m}^3$$

$$E_a = 63.4\%$$

$$E_r = 81.8\%$$

$$R_t = 0.366$$

$$R_p = 0.00$$

Table 1 provides a summary of the evaluation and a comparison with the design.

Table 1. Summary of evaluation and comparison with design.

Parameter	Evaluation (measured)	Evaluation (estimated)	Design ^{1/}
Inflow time, min	450	720	720
Average furrow inflow rate, ℓ ps	0.847	0.843	0.57-0.76 (9-12 gpm)
Design depth or requirement, mm	72	72	61 (2.4 in.)
Average depth applied, mm	58.4	93.0	70.0 (2.76 in.)
Average infiltrated depth, mm	41.4	58.9	56.5 (2.22 in.)
Water application efficiency, %	70.8	63.4	81.4
Water requirement efficiency, %	57.3	81.8	92.7
Tailwater ratio, dec.	0.292	0.366	0.186
Deep percolation ratio, dec.	0.00	0.00	0.00

^{1/}Values for average depth applied, average depth infiltrated and design performance parameters are averages for the 0.57-0.76 ℓ ps (9-12 gpm) range of furrow inflow rates.

CONCLUSIONS

1. It is obvious that the interrupted irrigation was inadequate. However, the uniformity of application was good.

2. Extrapolation of flow rates on the inflow/runoff hydrographs (to 720 min) yields an estimate of what the system performance would normally be under the farmer's current (12-hr set) operation. Assuming these results valid, the farmer would be doing only a fair job of replenishing the needed soil water and would have a large amount of runoff loss. Comparison with

the suggested design parameters indicates why this happens. First, the farmer's average furrow inflow rate for the irrigation is well above the suggested range. This would be a major reason for the high amount of runoff losses as compared to design. Second, the farmer irrigated at a higher soil water deficit than suggested by design analyses. This factor contributes to the under-irrigation which is occurring with his current management.

3. The initial design for this field was formulated for a design depth of 72 mm (2.8 in.), the approximate operating soil water deficit for the farmer. Only marginally acceptable levels of design performance could be obtained for these design conditions. Iterations of the design procedure for smaller design depths were carried out and a feasible design determined for a design depth of 61 mm (2.4 in.). The farmer could significantly improve system performance by altering his system management to apply a smaller amount (61 mm) on a more frequent basis. i.e., reducing the design depth from 72 mm (2.8 in.) to 61 mm (2.4 in.) shortens the irrigation interval by 1 to 2 days.

RECOMMENDATIONS

1. The farmer should consider altering his system management to the smaller design application depth as discussed. Given the range of furrow inflow rates suggested from the design, 0.57 to 0.76 ℓ ps (9 to 12 gpm), acceptable levels of system performance can be achieved.

2. Further evaluations of the irrigation system are necessary. If the farmer accepts the above design parameters then an evaluation of the new design and management is desired. Also, seasonal changes in factors and conditions which affect the system performance must be evaluated so that an efficient operation can be implemented throughout the season. The example presented has only illustrated the many factors and conditions to be considered for one irrigation of the season.

COLLECTION AND ANALYSIS OF MORE DETAILED DATA

Data Collection

When it is desirable to obtain more detailed information on the physical operating aspects of the irrigation system, the following measurements should be made in sequence with the procedures described previously.

Furrow Cross Section Data.--An estimate of the furrow cross-sectional area can be obtained through the use of the device shown in Figure 9. The furrow profilometer is placed in the furrow with the sliding rods just

resting on the furrow bottom. An identification marker of the location is placed next to the profilometer and a photo of them is taken. This should be done in several (at least three) preselected points along each of the furrows in which other measurements are made (i.e., advance/recession, inflow/runoff, etc.). Furrow cross section data should be collected both before and after the irrigation; it is suggested that these data be collected at the same time soil water content samples are collected. Care and good judgement should be exercised in the placement of the profilometer, making sure to place it in a representative section of the furrow without disturbing the soil.

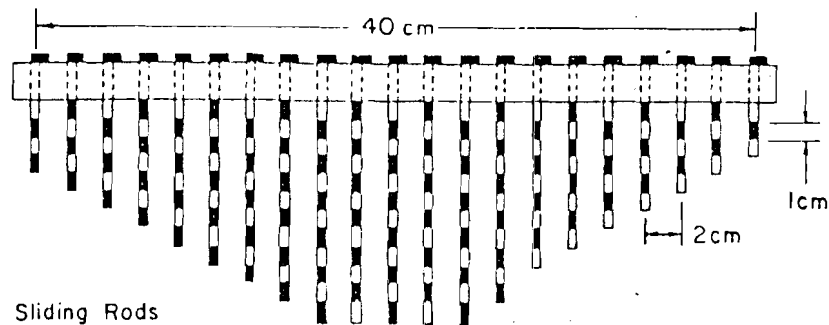

Figure 9. Furrow profilometer.

Flow Depth and Top Width Data.--The flow depth and top width are measured in each of the furrows in which inflow/runoff and advance/recession data are taken. Measurements should be made at several points along these furrows several times during the irrigation. These measurements should be taken at approximately the same location each time. When these data are collected, it is desirable to make the measurements as often as possible during the advance, and may be spaced out at 30 to 60-minute intervals during the rest of the irrigation.

Furrow Infiltration Data.--Another method for determining infiltration during furrow irrigation is the inflow-outflow method presented by Criddle, et al. (1956). Small flumes or other flow measuring devices are placed in the furrow at some spacing, i.e., anywhere from 25 m to 75 m. The inflow and outflow rates vs. time are recorded for each section. Flow depth and top width measurements are also taken in these sections. A volume balance procedure (discussed shortly) is used to determine an infiltration relationship. When these data are collected the measurements should be made in furrows other than those in which advance and recession data are collected.

Data Analyses

Furrow Profiles and Surface Storage.--Once the furrow cross section photos are ready, the data is transcribed to the appropriate data form. These data can then be analyzed, and in general, an empirical power relationship between center depth and cross-sectional area found:

$$A_f = ARy^{BR} \quad (12)$$

where A_f = furrow cross-sectional area (L^2),
 y = center depth (L),
 AR, BR = empirical constants.

The constants AR and BR can be found using a least squares technique. Usually a mean relationship for the entire furrow length is determined as follows:

- a. Graphically estimate the area of each cross section at depths of 1, 2 and 3 cm from the furrow bottom at the furrow centerline.
- b. Calculate the mean area for the furrow sections of each furrow at each depth.
- c. Perform a logarithmic transformation of Equation (A-1) and a least squares regression of the transformed variables to determine the constants AR and BR.

Assuming the empirical relationship for the furrow cross-sectional area (as just derived) is valid for the entire furrow length; flow depth data are used to find flow areas at each of the points where the flow depth is measured. Since flow depth data are available through the advance phase and the remaining phases of irrigation, an average cross-sectional flow area for the entire furrow length can be found for each of these phases. In turn, an estimate of the total volume of water in the furrow (surface storage) for a particular length, can be found by multiplying the average flow area by the furrow length being considered. The volume of surface storage may be necessary in certain volume balance analyses.

The cross-sectional flow area relationship and flow depth data are also used in estimating the furrow roughness in a relationship such as Manning's formula:

$$Q = \frac{C_u}{n} S_o^{1/2} R^{2/3} A_f \quad (13)$$

where Q = flow rate at a particular section (L^3T^{-1}),
 n = Manning's roughness factor,
 S_o = bed slope ($L L^{-1}$),
 R = hydraulic radius (L),
 A_f = cross-sectional flow area (L^2),
 C_u = constant dependent on units (1.0 for metric, 1.486 for English).

For such an analysis steady uniform flow in a prismatic channel of uniform slope is assumed. This allows usage of Manning's formula with the energy gradient equal to the furrow bed slope. The condition of steady uniform flow in furrow irrigation is approximated at the time when the soil has reached its basic intake rate. Thus, flow depth data only for about the last half of the irrigation should be used. The flow rate at any particular section along a furrow is assumed to decrease linearly from the inflow rate to the runoff rate when the soil is at its basic intake rate. Hence, Equation (A-2) can be solved for Manning's n since the other variables can be estimated (i.e., R and A_f are found from the furrow cross section relation and flow depth data). Point estimates of n will result, which are averaged to find the mean furrow roughness.

Furrow Infiltration by Inflow-Outflow.--Criddle, et al. (1956) present a complete method for analyzing data collected in the inflow-outflow procedure. It involves a volume balance procedure using the inflow-outflow rate measurements to determine the furrow infiltration vs. time. Since flow depth data are available for the sections of furrow being evaluated, the volume of surface storage for those sections can be found as described previously. These estimates of surface storage volume are time distributed as are the inflow rate and outflow rate measurements. A volume balance as follows results in a time distribution of the volume infiltrated.

$$VINF(t) = VIN(t) - [VOUT(t) + VSS(t)] \quad (14)$$

where

$VINF(t)$ = total volume infiltrated at time t , (L^3),

$VIN(t)$ = total volume of inflow to furrow section at time t , (L^3),

$VOUT(t)$ = total volume of outflow from furrow section at time t , (L^3),

$VSS(t)$ = volume of water in surface storage at time t , (L^3).

In general, a functional relationship for infiltration can be determined for the data: volume infiltrated vs. time. More complete discussion of the method is found in Criddle, et al. (1956).

EQUIPMENT LIST AND SUGGESTED DATA FORMS

Equipment

The following list of equipment necessary for the evaluation of three furrows is suggested.

1. Six flow measurement devices (i.e., small cutthroat flumes with 1-in. throats).
2. Engineer's level, field rod, chain or tape, orange flagging.
3. Wood stakes and lathe for station markers, crayon for marking and hatchet for driving them into ground.
4. Soil sampling equipment:
 - a. soil auger or tube sampler
 - b. soil sample cans with tight fitting lids (up to 200, 2-in. diameter cans)
 - c. box for carrying cans
5. Small carpenter's levels for leveling flumes, etc.
6. Blocked furrow infiltration equipment (up to 10 sets, see Figure 1) plus plastic sheeting.
7. 50 small wire stakes with orange flagging.
8. Bulk density equipment.
9. Instruments for measuring time (stop watch, wrist watch with second hand).
10. Buckets for hauling water.
11. Shovels, sledge hammers.
12. Soil uniformity box (partitioned box).
13. Pencils, clipboards and data forms.

For the more detailed measurements include:

14. Device for measuring flow depth and top width.
15. Furrow profilometer (see Figure A1).
16. Camera, film and identification marker.
17. Small flow measurement devices for furrow infiltration by inflow-outflow method.

Data Forms

Data forms for the following data sets are provided:

Soil Water Content Data

Bulk Density Data

Blocked Furrow Infiltration Data

Water Advance/Recession Data

Flow Rate Data

Farm and Field Data

Flow Depth and Top Width Data

Furrow Cross-sectional Area Data

Furrow Infiltration Data (Inflow-Outflow Method).

Each form includes a special code for identification of the evaluation site:

Ident (R_E , F_A , F_I , I, F_u),

where the data are identified by the letters in parenthesis.

R_E --Region

F_A --Specific Farm

F_I --Field Number on Farm

I--Irrigation Number (starting from the first irrigation at that location)

F_u --Furrow Number

APPENDIX A RECONNAISSANCE QUESTIONNAIRE

1. Farmer operation and management

How does the farmer decide when to irrigate?
What is his irrigation frequency? How does it change during the season?
How does he decide how to irrigate?
How does he decide how much water to apply?
Does the farmer know the total flow rate available to him?
What are the farmer's operating hours?
Does he irrigate at night?
How does he decide how long to irrigate a field?
How long does he irrigate a field?
Does the farmer have any problems with the system?
What are his cultivation and tillage practices?
Does he irrigate every furrow or alternate furrows?
How many furrows does he irrigate in one set?
How many sets does it take to irrigate the field?
Does he try to compact the furrows equally?

2. Water supply

What are the sources of available water?
Is the delivery station (point of diversion to farm) a problem, i.e., high losses, etc.?
Is the on-farm distribution system a problem (i.e., too many in-field channels, high losses, etc.)?
What is the flow rate of each source of water?
When is each source available and for how long?
Is the frequency of delivery and available head a problem?
What is the water quality?
How is the water delivered to each field?

3. Crop characteristics

What are the crops being grown?
What are the respective planting dates?
What cropping patterns, if any, have been followed?
Does the farmer have any major problems in crop production?
What are the major inputs? Potential yield?
What is his expected yield? Average yield in area?
Any obvious physical symptoms of problems?

4. Physical characteristics

Does the farmer know the field dimensions?
Does he know the slope and cross-slope (if any)?
Has the field been leveled to a uniform slope?
If yes, when? If no, why not?
What provisions, if any, are made for surface runoff?
Does runoff leave the farm or is it used again somewhere on the farm?
What is the border spacing and how did the farmer decide on that spacing?
What is the furrow spacing?
What is the method of diverting water into each furrow?

5. Soil survey

Does the farmer know the soils on his farm?
Does he know of any trouble spots (i.e., very light or heavy soils
or salinity problems)?

6. Water table

Does the farmer know the groundwater level?
Does he feel it is a problem?
Is surface/subsurface drainage provided? If so, where?

BIBLIOGRAPHY

- Black, C. A., D. D. Evans, J. L. White, L. E. Ensminger, and F. E. Clark, editors. 1965. Methods of Soil Analysis, Part 1, Monograph Series No. 9, American Society of Agronomy, Inc., Madison, Wisconsin.
- Egypt Water Use and Management Project. 1979. Problem Identification Training Manual for On-Farm Irrigation Systems, Volume II. Egypt Water Use and Management Project, Colorado State University, Fort Collins, Colorado.
- Garcia, I. 1978. Soil-Water Engineering Laboratory Manual. Department of Agricultural and Chemical Engineering, Colorado State University, Fort Collins, Colorado.
- Hagan, R. M., H. R. Haise, and T. W. Edminister, editors. 1967. Irrigation of Agricultural Lands. Monograph Series No. 11, American Society of Agronomy, Inc., Madison, Wisconsin.
- Hart, W. E. 1961. Overhead Irrigation Pattern Parameters. Agricultural Engineering, 42(7):354-355.
- Hart, W. E. 1975. Irrigation System Design. Department of Agricultural and Chemical Engineering, Colorado State University, Fort Collins, Colorado.
- Ley, T. and W. Clyma. 1980. Design of Graded Border Irrigation Systems. Notes for AE535. Department of Agricultural and Chemical Engineering, Colorado State University, Fort Collins, Colorado.
- Ley, T. and W. Clyma. 1980. Design of Graded Border Irrigation Systems. Notes for AE535. Department of Agricultural and Chemical Engineering, Colorado State University, Fort Collins, Colorado.
- Reuss, J. O., S. A. Qureshi, and N. M. Chaudhry. 1975. Evaluation of Errors in Gravimetric Determination of Soil Water, Appendix 1. Annual Technical Report, Water Management Research Project, Colorado State University, Fort Collins, Colorado.
- Staple, W. Y. and J. J. Lehane. 1962. Variability in Soil Moisture Sampling. Canadian Journal of Soil Science, Vol. 42, February, pp. 157-164.
- USDA. 1974. Border Irrigation. National Engineering Handbook, Section 15, Chap. 4, Soil Conservation Service, U.S. Department of Agriculture.
- USDA. 1978. Draft of Furrow Irrigation. National Engineering Handbook, Section 15, Chap. 5, Soil Conservation Service, U.S. Department of Agriculture.

EWUP

How to do it

Field Procedure



EVALUATION OF GRADED BORDER IRRIGATION SYSTEMS^{1/}

Thomas W. Ley and Wayne Clyma^{2/}

INTRODUCTION

Data collection and analysis procedures for evaluating the performance of graded border irrigation systems are presented. Information is collected on both the physical and managerial aspects of operational systems. Basic data reduction procedures define the state of the irrigation system. A list of suggested equipment and data forms are included.

REQUIRED DATA

Preliminary Data

The evaluation of any irrigation system necessarily requires the collection and analysis of a large amount of data. Not the least of which are basic preliminary site data which can be obtained through interviews with the farmer and by performing several basic physical measurements. Basic site information must be known before the evaluation of an irrigation occurs. It is also desirable to obtain as much information as possible from the farmer concerning his operation and management of the irrigation system before an irrigation is evaluated. A list of suggested questions is found in Appendix A for each of the following categories of information. The list, is by no means exhaustive, and often the farmers answers to some of the questions will lead the trained person to other more site specific questions.

^{1/}Prepared under support of United States Agency for International Development, Contracts AID/NE-C-1351 and AID/DSAN-C-0058. All reported opinions, conclusions or recommendations are those of the authors and not those of the funding agency of the United States Government.

^{2/}Research associate and associate professor, respectively, Agricultural and Chemical Engineering Department, Colorado State University, Fort Collins, Colorado.

1. Farmer operation and management.--Understanding why or how a farmer does certain things in managing and operating the irrigation system is vital. Often this aspect of evaluating irrigation performance may be overlooked and incomplete knowledge of the irrigation system state results. Farmer management may be constraining the level of performance which can be attained. The general level of knowledge of the farmer concerning irrigation principles and practices is evaluated. Other information discussed later will aid in determining if system management can be improved.

2. Water supply.--The farmer will know the available water supply, source, delivery, frequency, etc. He may have only a general knowledge of the flow rate and quality. These should be measured during the course of an evaluation. On-farm conveyance losses may be a big problem. The farmer may or may not know. Measure the losses if necessary.

3. Crop characteristics.--The crops grown and the planting dates of each must be known. Available data in the literature are needed on crop seasonal water requirements, rates and stages of growth, maximum potential rooting depths, time from planting to effective cover, etc. This information along with climatic data is used to estimate crop water use through the irrigation season. The crop root zone should be measured at each irrigation for crops with expanding root systems. The measured root zone for a perennial crop (such as alfalfa) can often be assumed valid for the entire season unless a fluctuating water table is encountered. The crop root zone at each irrigation determines the available soil water reservoir at that time and is necessary to determine the soil water deficiency, the stress at the time of irrigation and performance parameters such as water application and water requirement efficiencies.

4. Physical characteristics.--Measure and record the field dimensions. Stakes should be driven into the ground at 25-m intervals along the length (adjust for size of field as necessary). Measure and record surface elevations at each stake (station) using a field rod and level. Plot the surface profile (elevation vs. length). Measure and record the cross-slope and border spacing at each station. Determine if a ponded or free outflow boundary condition exists at the downstream end. Determine where and how to measure border inflow and runoff.

5. Soil survey.--If available, obtain information on soils in the area (on the farm), such as maps and classifications from a local or

regional office (e.g., USDA Soil Conservation Service or similar government agency). Such information is very useful and aids the design of data collection procedures. Soil types and textures are known and maps usually depict the variation of surface textures in a field. If this information is not available a soil survey is necessary to determine the soil types and uniformity in the field being studied. Soil samples should be collected in a minimum of ten locations in the field (i.e., at five locations along the length and two along the width). Samples should be taken from a minimum of four depths within the expected root zone, i.e., every 30 cm in an expected 1.2 m root zone (adjust as necessary). These samples should be analyzed to determine soil types.

Once soil types and variations through the field are known the apparent specific gravity of the soil (bulk density), the field capacity and wilting point of the soil must be determined. Garcia (1978) presents procedures for these measurements. Depending on the results of the soil survey the sample collection procedure is defined. For a field with uniform soils it is necessary to collect data on the above soil properties in a minimum of three locations in the field to obtain a good average. It is necessary to sample with depth. For a field with non-uniform soils the above soil properties must be determined for each major soil type. A minimum of three replications of samples is necessary to obtain an average. Sampling with depth is required. See Appendix B for further discussion.

Accurate definition of the above soil properties is necessary. The time and effort necessary to achieve accurate data will eliminate having to repeat any sampling. These data are most easily collected before the crop is planted. Some change of apparent specific gravity of the plow layer with time may be expected. Sampling plans for soil water content and infiltration tests will be functions of soil type and uniformity. The results of the soil survey should thus be available in advance of the initial irrigation evaluation.

If soil salinity/alkalinity is expected to be a problem (indicated by maps, previous surveys, information from the farmers), samples should be analyzed to determine the salinity/alkalinity. Such a problem may also indicate the presence of a high water table.

6. Water table.--The farmer should have general knowledge of water table conditions in the area. Soil survey results may indicate a high water

table. If the water table is high or expected to fluctuate considerably (i.e., within the maximum potential root zone), it is desirable to monitor the ground water level through the irrigation season. This can be done with a series or grid of observation wells (EWUP, Vol. II, 1979).

A high water table can limit crop growth through water-logging. The groundwater quality can also seriously affect crop growth and should be measured.

Crop water use from the capillary fringe or the water table is possible. Estimates of crop consumptive use by evapotranspiration modeling techniques will not correspond with measured soil water deficits (by soil water content sampling) when the crop is using groundwater, assuming each method is yielding accurate results. This is significant if the water table rises during the season due to early overirrigation. Water table fluctuations due to overirrigation may also contribute to crop consumptive use and can affect root zone expansion.

On the Day before Irrigation

Preirrigation Soil Water Content Data.--Garcia (1978) presents procedures for the collection and analysis of soil samples for determining water content by the gravimetric method. Depending on the results of the soil survey (which should be available by this point in time), the sampling plan is devised. If the soil survey results show the soils to be uniform, a minimum of three locations in different parts of the field are selected for sampling to obtain an average for the field. However, if certain variations are expected (non-uniform water applications, etc.) or if soils are non-uniform a minimum of three replications of samples should be collected where the non-uniformities are or where variations are expected. For instance, non-uniform water applications along the length of run is common and collection of a minimum of three replications of samples at a minimum of three representative locations along the length is suggested. See Appendix B for further discussion on sampling and how often to sample.

In all cases, samples should be collected from each of several layers of the measured or expected maximum rooting depth of the crop (i.e., for a 1.2 m root zone, sample each 30-cm layer, and in the top 30-cm layer collect samples from each 15-cm increment). If the water table is higher than the expected maximum rooting depth, samples should be collected to the water table. Each individual sample should be 150 grams or more.

Other preparations for the evaluation should be made on the day before irrigation such as installation of flow measuring devices and cylinder infiltrameters. Contact the farmer and find out the time he expects to start irrigating. Plan to arrive in sufficient time to complete all preparations for the evaluation(s) such as preparation of data forms and assignment of duties.

On the Day of Irrigation

Infiltration Data.--For uniform soils at least three and preferably a total of six cylinder infiltration tests should be conducted in three locations along the length. For non-uniform soils three replications of tests should be made in each area where a different soil texture exists. If non-uniformity in distribution along the length of run is anticipated, then three replications for each representative length of the field is necessary to delineate these differences. During the season differences in soil water content will accentuate the differences in infiltration and the distribution of water. See Appendix B for further discussion of considerations of where to sample and how often.

The infiltrometer measurements should be started as the water arrives at each infiltrometer and the ponded depth maintained the same as the depth of flow of the irrigation water. If the tests cannot be conducted during irrigation, they should be conducted on the day before irrigation and a buffer ring should be used. Garcia (1978) presented procedures for installing the infiltrometers and conducting the tests.

Inflow/Runoff Data.--Flow measurement devices to determine inflow to and runoff from the border should be properly installed before the irrigation. The clock time^{1/} at which water is first introduced to the border should be recorded. A measurement of the initial inflow rate should be taken. Periodically during the irrigation record the inflow rate and clock time of the observation. When the water reaches the runoff measurement device begin making runoff rate vs. time measurements. A suggested pattern for taking runoff data from the time runoff starts is to take a reading at 30 sec, 1 min, 2 min, 4 min, 8 min, 15 min, 30 min, and then every 1/2 hour. Record the clock time when water entering the border is terminated.

^{1/} Clock times should be on a 24-hour basis (military time).

Advance/Recession Data.--The rate of waterfront advance should be observed and recorded. When the moving stream front is irregular, record the time when an "average" front reaches each station (see Fig. 1). After the inflow is terminated, record the rate of recession. Ideally, this would be the time when water disappears from each station. It is difficult to determine the location of the receding water edge. When water has disappeared from 50 percent of the grid surface area represented by each station, recession is assumed to have occurred at that station. Consistency is of primary importance in taking recession data.

After Irrigation

Postirrigation soil water content samples should be collected anywhere from 1-1/2 days to 3 days after irrigation. This depends on the soil type and the time required for the soil to drain to field capacity. Garcia (1978) presents a field procedure for estimating when (after wetting) a soil has drained to field capacity. The same collection procedures as previously discussed apply.

DISCUSSION AND RECOMMENDATIONS

To ensure cooperation of the farmer during the evaluation, describe exactly what will be done. Minimize crop damage and soil disturbance. Be sure the farmer will operate his system as he usually does. Avoid remarks which may influence his management decisions. The purpose of the evaluation is to determine the system performance and evaluate the system operation as the farmer currently manages it.

It is important that preliminary data collected early in the season be good data. A careful, coordinated, determined effort here will save much time and eliminate problems and headaches later in the season. For instance, the soil water content of a field before the initial irrigation of the season may generally be assumed as uniform. Much effort in careful soil sampling and in collection of more samples (to increase the precision with which the mean soil water content is estimated) is recommended. The establishment of this initial condition serves an important purpose. It is the starting point for a root zone soil water budget.

From this initial condition, water added to the root zone of the crop by precipitation (measured by rain gages set up in several locations at the site), and by irrigation (measured by irrigation evaluations) is known. Crop use is estimated using climate data and crop stage and growth

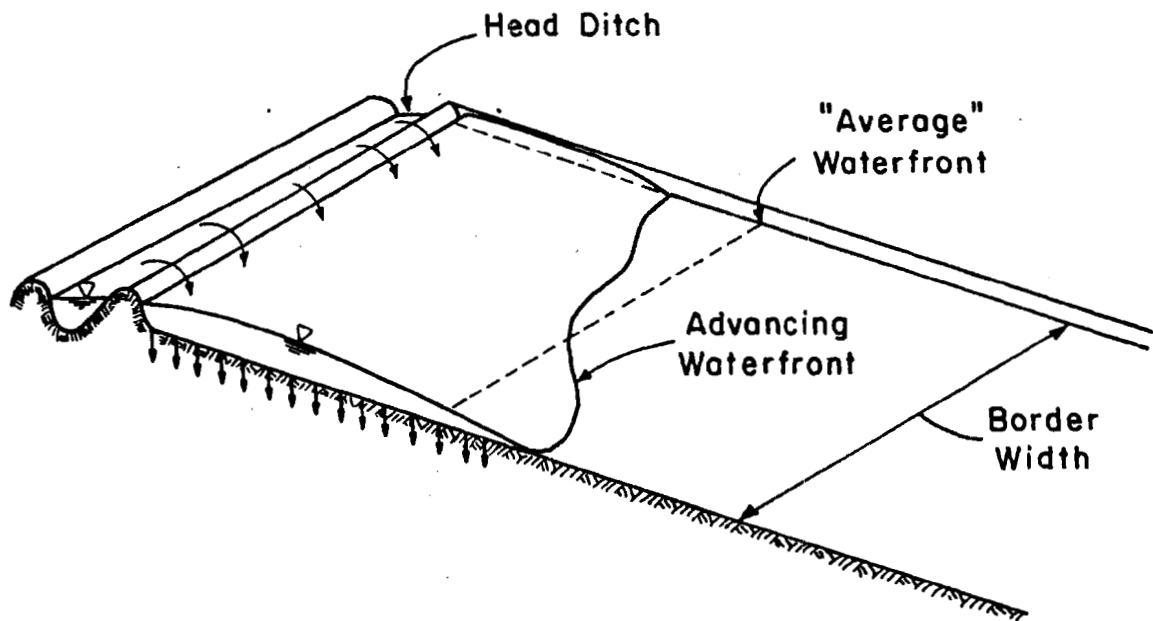

Figure 1. Illustration of irregular waterfront advance and location of "average" waterfront.

data in an accurate, calibrated evapotranspiration model. A root zone soil water budget can thus be calculated through the season. Soil water content data collected at succeeding irrigations of the season are used as a check on the predicted soil water status when calibration of the ET model is necessary.

If there is a high water table in the area, crop use from the capillary fringe or the water table itself can be estimated. The difference between the calculated crop use and the measured soil water deficit (by sampling) during an irrigation interval is an estimate of the crop use from the water table during that interval. If there is no reason to believe that the crop is using water from a water table, then the computed difference indicates the accuracy of each method and possibly needed action to improve sampling or predictive techniques.

In some instances, collection of advance/recession data may not be necessary at each irrigation. For instance, a uniform application of water may be expected on a field with shorter lengths of run on a heavier soil. In this case, the distribution is assumed uniform and all that is required is the water on and water off to determine the water added to the soil. While this case may occur, it is advisable to collect advance and recession data when any non-uniformity of water application is suspected due to poor irrigation practices, non-uniform soils, non-uniform field slopes, etc. in order to know the distribution of applied water.

During the course of an actual irrigation evaluation, it is recommended that a partial evaluation of the data being collected be conducted. This is accomplished best by processing the data as it is collected in the field and interpreting the results. For instance, it is easy to evaluate inflow and runoff data. An obvious error is determined if the runoff is greater than the inflow. This check on data provides the investigator a means of eliminating wasted time and effort in the collection of erroneous data.

FIELD DATA ANALYSIS

Field data analysis provides a basis for understanding the performance of the irrigation system and how the system is being operated. The data may be analyzed through a number of procedures. Those presented here represent the minimum of analyses required to formulate an understanding of the system's performance resulting from a particular management scheme.

Soil Water

The soil water content may be estimated by two methods: 1) gravimetric method, and 2) feel method. The soil water content expressed as a depth of water per unit depth of root zone can be estimated using the results of the gravimetric soil water analyses in the following equation:

$$d_m = \sum_{i=1}^n (P_{w,i} \cdot \gamma_{b,i} \cdot y_i) \quad (1)$$

where d_m = the soil water content expressed as a depth (L) for the entire depth investigated,

$P_{w,i}$ = dry weight soil water content for the i th layer of the root zone (MM^{-1}),

$\gamma_{b,i}$ = soil bulk density in the i th layer [$(ML^{-3})(ML^{-3})^{-1}$],

y_i = thickness of the i th soil layer (L),

n = number of layers in the root zone which were sampled.

The pre-irrigation soil water content data are checked with the soil field capacity to estimate the soil water deficit (available root zone storage) at the time of irrigation. As previously discussed, crop water use and root zone soil water budgeting also provides a check on the soil water deficit at irrigation time. The pre- and post-irrigation soil water data can also be useful in analyzing depths infiltrated and adequacy of irrigation along the border assuming there is no deep percolation of water below the lowest depths investigated.

The feel method for estimating soil water content is largely subjective since it is dependent upon visual inspection of certain characteristics of the soil sample. The method should be used only when the investigator has a large amount of experience and even then only for a rough estimate of soil water content. Table 1 describes the relationship between soil physical appearance and soil water content for varying soil types.

Advance and Recession

The advance and recession data are plotted on coordinate paper as shown in Figure 2. The advance curve is a plot of the time the waterfront advances along the border vs. the length of the border. The recession curve is a plot of the time the waterfront recedes from the surface vs. the border length. The intake opportunity time is the difference between the advance and recession time as shown in Figure 2. Intake opportunity times represent

the amount of time water has the opportunity to infiltrate at points along the border. Surface elevation data are often plotted on the same graph as an aid in explaining variations in advance and recession rates, and resultant effects on infiltration opportunity time.

Infiltration Relationship

The data from cylinder infiltration rests are reduced to the form of cumulative depth of infiltration vs. time. The reduced data are then plotted on log-log paper (Garcia, 1978). In general, the data plot as straight lines, but may slightly curve and often will "dogleg." Some curves steepen after a few minutes either because of release of trapped air (usually in sandier soils) or because the cylinders were not driven deeply enough. Soils which have cracks, into which water disappears quickly, often exhibit curves which are initially steep and then flatten. Plow plans may cause a similar, but usually delayed effect. The average infiltrated depth vs. time should be computed using the data from each area where soil properties were found to be uniform (Merriam and Keller, 1978). The average infiltrated depth vs. time should then also be plotted on the same log-log graph as the individual data sets for these areas. A least squares regression technique (see Garcia, 1978) is often used to find an infiltration function of the following form for the average infiltrated depth vs. time:

$$z = kt^a$$

where z = cumulative depth infiltrated (L), (2)

t = time (T)

k, a = empirical constants.

This type of infiltration function is usually considered representative in border irrigation. In most cases, the infiltration relationship resulting from ring infiltration tests is inadequate in predicting the actual infiltration which occurs during the irrigation. The actual average infiltrated depth can be found using inflow and runoff data (discussed later) for the irrigation. The following procedure is used to find the predicted average infiltrated depth (as predicted by the infiltration relationship).

1. Using intake opportunity times (from advance/recession data) for stations along the border and the infiltration relationship, find the predicted infiltrated depth at each station.

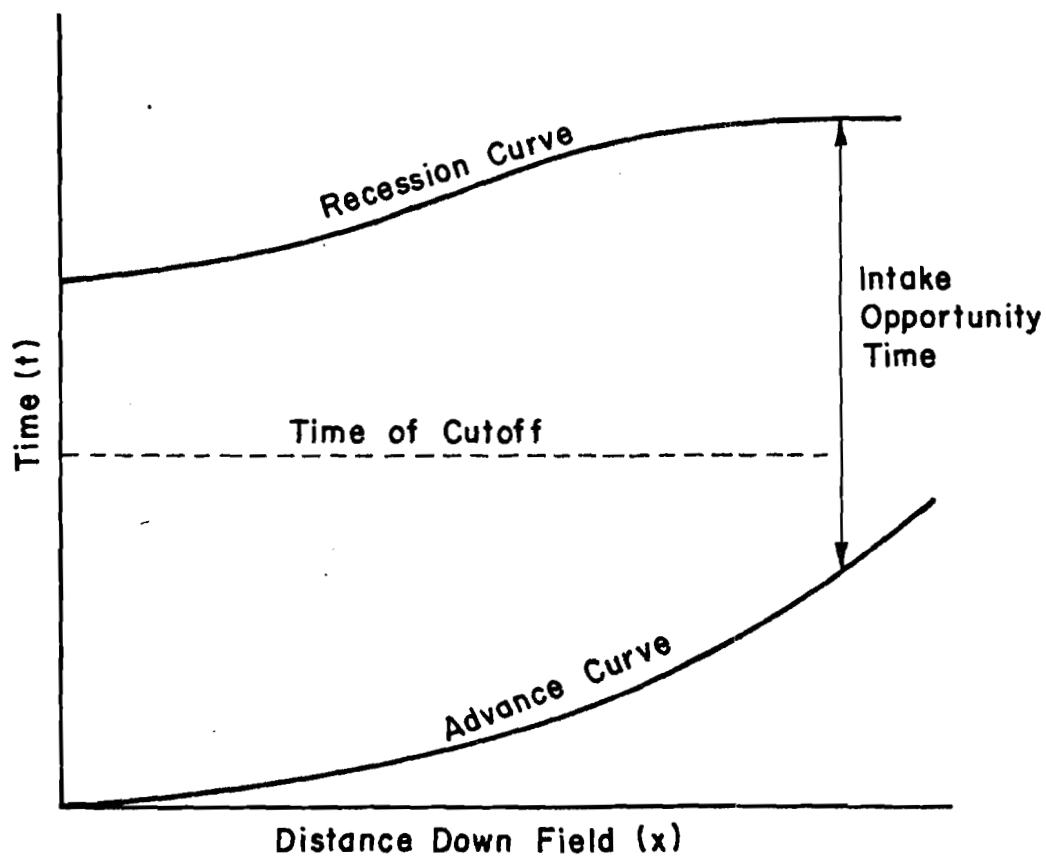

Figure 2. Typical advance and recession curves for border irrigation.

Table. 1. Soil moisture deficiency and appearance relationship chart (after Merriam and Keller, 1978).
 (This chart indicates approximate relationship of soil moisture deficiency between field capacity and wilting point. For more accurate information the soil must be checked by drying samples.)

Moisture Deficiency (in./ft)	Soil Texture Classification				Moisture Deficiency (in./ft)
	Coarse (loamy sand)	Sandy (sandy loam)	Medium (loam)	Fine (clay loam)	
0.0	Leaves wet outline on hand when squeezed	Appears very dark, leaves wet outline on hand, makes a short ribbon	Appears very dark, leaves wet outline on hand, will ribbon out about one inch	Appears very dark, leaves slight moisture, on hand when squeezed, will ribbon out about two inches	0.0
0.2	Appears moist makes a weak ball	Quite dark color, makes a hard ball	Dark color, forms a plastic ball, slicks when rubbed	Dark color, will slick and ribbons easily	0.2
0.4	Appear slightly moist sticks together	Fairly dark color, makes a good ball	Quite dark, forms a hard ball	Quite dark, will make thick ribbon, may slick when rubbed	0.4
0.6	Dry, loose, flows thru fingers. (wilting point)	Slightly dark color, makes a weak ball	Fairly dark, forms a good ball	Fairly dark, makes a good ball	0.6
0.8	Lightly colored by moisture, will not ball	Slightly dark, forms weak ball	Lightly colored, small clods crumble fairly easily	Will ball, small clods will flatten out rather than crumble	0.8
1.0		Very slight color due to moisture (wilting point)	Slight color due to moisture, small clods are hard (wilting point)	Some darkness due to unavailable moisture, clods are hard, cracked (wilting point)	1.0
1.2					1.2
1.4					1.4
1.6					1.6
1.8					1.8
2.0					2.0

174

Field Method of Approximating Soil Moisture (Deficiency) for Irrigation; Transactions of the American Society of Agricultural Engineers, Vol. 3, No. 1, 1960; John L. Merriam, Professor, California Polytechnic State University, 1975, San Luis Obispo, California.

177

2. Determine the average infiltrated depth for each reach (distance between stations) by averaging the predicted infiltrated depths of successive stations.
3. Determine the predicted average infiltrated depth for the entire border by summing the reach averages (found in 2) and dividing by the number of reaches. Keep in mind that this value is an estimated or predicted value resulting from the use of the empirical infiltration function.

Inflow and Runoff

Inflow and runoff data provide a simple means of determining the actual average infiltrated depth. The inflow and runoff hydrographs are constructed on the same rectangular grid by plotting inflow and runoff rates vs. time. An estimate of the total volume of water applied, $W_a(L^3)$, is found by graphically integrating the area under the inflow hydrograph. An estimate of the total runoff volume, $W_u(L^3)$, is found by graphically integrating the area under the runoff hydrograph. An estimate of the total infiltrated volume, $W_i(L^3)$ is found by taking the difference as follows:

$$W_i = W_a - W_u \quad (3)$$

The actual average infiltrated depth can then be determined by dividing W_i by the product of the border width and length.

Adequacy of Infiltration Relationship

Once both the predicted average infiltrated depth and the actual average infiltrated depth have been found they are compared. This is a check on the adequacy of the empirical infiltration function in predicting the average infiltrated depth. If the two values are not approximately equal (i.e., less than 5 to 10 percent difference), then the infiltration relationship should be adjusted accordingly until the predicted value is approximately equal to the actual value. The adjustment procedure is done either graphically or numerically and involves finding a new value for the multiplicative constant in Equation (2), while the value of the exponent remains the same (Merriam and Keller, 1978). On the log-log plot, this implies the slope of the curve remains constant and the curve is either shifted upwards or downwards. Both the graphical and numerical procedures are much more fully and easily explained in the example evaluation presented later.

Runoff Data Not Available.--When runoff data are not available, then the adequacy of the infiltration function must be checked using a different method (Merriam and Keller, 1978). In this case, the checkpoint is the actual average applied depth rather than the actual average infiltrated depth. The method requires the extrapolation of the advance and recession curves to their intersection. This provides an estimate of how far the water would have spread if the downstream boundary condition at end of the border was an imaginary extended border length, and is a means of accounting for all of the water applied. The predicted average applied depth is found by utilizing intake opportunity times in the infiltration relationship as previously discussed. Now, however, the opportunity times for the imaginary extended length must be included in the analysis. The actual average applied depth is found by dividing the total applied volume by the imaginary wetted area (i.e., the product of border width and total imaginary extended length). Comparison of the predicted average and actual average applied depths indicates if adjustment of the infiltration relationship is necessary. This procedure is obviously not as accurate as that used when runoff data are available due to the errors introduced in extrapolation of the advance and recession curves.

Subsurface Distribution

The subsurface distribution of applied water in border irrigation can be determined when the following information is known.

1. A representative infiltration function (as determined above).
2. Infiltration opportunity times along the irrigated run, i.e., advance and recession times at points along the run.

Upon construction of the subsurface profile, it is possible to characterize the performance of a particular irrigation. However, before irrigation performance parameters are defined it is necessary to define several related quantities upon which they depend.

Figure 3 represents an idealized profile of infiltrated water as a result of border irrigation. The distance AB is the border length, and the line DFG is the boundary of the infiltrated water. If the downstream boundary condition is one of free outfall, then runoff water from the field can be assumed to extend to the imaginary field length C, and to infiltrate according to the profile CD. The water requirement depth at the time of irrigation is assumed uniform along the border length and is represented by

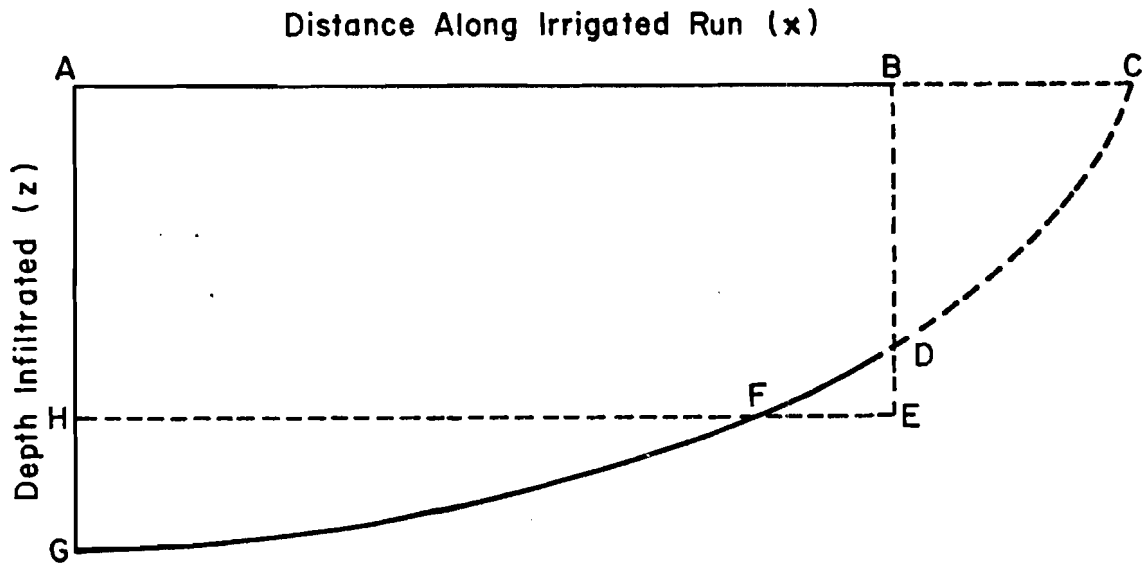

AB	length of border (L)
ACDGA	total volume of applied water per unit field width, $W_a (L^3 L^{-1})$
ABEHA	total volume of requirement per unit field width, $W_r (L^3 L^{-1})$
ABDFHA	total volume of actual root zone storage per unit field width, $W_{rz} (L^3 L^{-1})$
FGHE	total volume of deep percolation per unit field width, $W_r (L^3 L^{-1})$
BCDB	total volume of runoff water per unit field width, $W_u (L^3 L^{-1})$
DEFD	total volume of root zone deficit after irrigation per unit field width, $W_{df} (L^3 L^{-1})$

Figure 3. Idealized subsurface profile of applied water in border irrigation.

line EFH. With these concepts in mind the following quantities with appropriate units are defined in Figure 3.

1. Total volume of applied water, W_a (area ACDGA). This is the total volume of water introduced per unit width of border.
2. Total volume of water required in the root zone to reach field capacity, W_r (area ABEHA). This is the volumetric soil water deficiency.
3. Total volume of water stored in the root zone, W_{rz} (area ABDFHA). This volume of water is dependent upon the field capacity of the soil and the available storage at the time of irrigation. The total volume of water available for plant use after the irrigation and drainage period equals the difference between the field capacity (FC) and the permanent wilting point (PWP) of the soil, if the root zone is completely filled during irrigation [i.e., the total available water expressed as a depth, $TAW = (FC - PWP) \times (\text{bulk density of the soil}) \times (\text{rooting depth})$].
4. Total volume of deep percolation, W_p (area FGHF). The volume of water which infiltrates past the lower boundary of the root zone. W_p may equal zero in some cases.
5. Total volume of tailwater or runoff, W_u (area BCDB). The volume of water which runs off the end of the field if free outfall conditions exist.
6. Total volume of root zone deficit after irrigation, W_{df} (area DEFD). W_{df} equals zero if the root zone is completely filled.

The total volume of water applied and the total volume of runoff can be cross-checked with the hydrograph analyses discussed earlier, when such data are available. Volumes can be converted to average depths by dividing by the product of border width and border length.

Irrigation Performance Parameters

Four irrigation performance parameters are discussed and may be defined using either volumes or depths.

1. Water application efficiency, E_a , is the percent of the amount of water applied which is stored in the root zone for future use.

It is a measure of the effectiveness of the irrigation in storing water.

$$E_a = \frac{W_{rz}}{W_a} \cdot 100 = \frac{D_{au}}{D_a} \cdot 100 \quad (4)$$

where W_{rz} and W_a are as defined previously, and D_{au} and D_a are the corresponding average depths (L) associated with these volumes, respectively.

2. Water requirement efficiency, E_r , indicates the percent of the amount of water required to refill the root zone, which is supplied by an irrigation. It is a measure of the effectiveness of the irrigation in meeting the crop requirement.

$$E_r = \frac{W_{rz}}{W_r} \cdot 100 = \frac{D_{au}}{D_u} \cdot 100 \quad (5)$$

where W_{rz} and W_r are as defined previously, and D_{au} and D_u are the corresponding average depths (L) associated with these volumes, respectively.

3. Tailwater ratio, R_t , represents the fraction of the total amount applied which is lost as tailwater or runoff from the end of the border.

$$R_t = \frac{W_u}{W_a} \quad (6)$$

where W_u and W_a are volumes (L^3) as previously defined.

4. Deep percolation ratio, R_p , represents the fraction of the total amount applied which is lost as deep percolation past the bottom of the root zone.

$$R_p = \frac{W_p}{W_a} \quad (7)$$

where W_p is as previously defined.

It is pointed out that the sum of the water application efficiency (expressed as a fraction), the tailwater ratio, and the deep percolation ratio is unity.

Another performance parameter often used describes the uniformity of water application. It may be unnecessary, however, when a plot of the

subsurface distribution of applied water (as discussed earlier) is available. This parameter is a measure of the uniformity of the spatial distribution. Several techniques for characterizing the spatial distribution of infiltrated water have been developed. One of the more common and more easily calculated parameters is UCH, the Hawaiian Sugar Planter's Association uniformity coefficient (Hart, 1961):

$$UCH = 1 - \sqrt{\frac{2}{\pi}} \frac{s}{\bar{x}} = 1 - 0.798 \frac{s}{\bar{x}} \quad (8)$$

where \bar{x} = the mean infiltrated depth (determined from several observations),
 s = the standard deviation of the observations.

EXAMPLE SYSTEM EVALUATION

The following discussion presents the results of an evaluation of a graded border irrigation system as the farmer was currently operating it. The original data are taken from Merriam and Keller (1978). The value of being able to describe system operation and performance through an evaluation, and then comparing the results to an appropriate design is illustrated. A design for the field was formulated using the SCS border irrigation design procedure (USDA, 1974). The results of this design are presented in a separate analysis of the design procedure (Clyma, 1980). Changes in system operation and management for improved water application are more easily recognized when compared to the design.

Unfortunately, for this particular evaluation, runoff data and postirrigation soil water content data are not available. The preirrigation soil water status was evaluated using the feel method previously discussed. Recommended design parameters are repeated here for the reader's convenience.

$$\begin{aligned} Q_u &= 4.31 \text{ l/s-m (0.0464 cfs/ft)} \\ T_a &= 118 \text{ min} \\ \text{strip width} &= 7.9 \text{ m (26 ft)} \\ \text{design depth} &= 114 \text{ mm (4.5 in.)} \end{aligned}$$

The farmer was operating the system using the full available stream of 34 lps (1.2 cfs) on a border strip width of only 7 m (23 ft) and border length of 210 m (700 cfs). This gives a unit width stream of 4.83 l/s-m (0.052 cfs/ft) (which is larger than the design value due to smaller border width). Due to harvest operations, the farmer scheduled a more frequent

water application. The application time was 88 minutes and the soil water deficit at the time of irrigation was estimated to be 74 mm (2.9 in.).

Four cylinder infiltration tests were conducted during the evaluation in four locations along the length since the soil was found to be fairly uniform. These data, in the form of cumulative depth infiltrated versus time, are plotted in Figure 4. A wide range of initial intake rates is observed. However, after approximately 30 minutes, the data curves have nearly the same slope. The average cumulative intake vs. time was determined from the four sets of data and is also plotted in Figure 4 (as the curve labeled "average"). As can be seen, there is a significant dogleg in this curve (Merriam and Keller, 1978). Since all of the data plots exhibit nearly the same slope after 30 minutes, it was decided a straight line typical of this condition but also typical of the wide range of initial rates was most representative. The curve labeled "typical" is the result. It is felt that the "typical" curve provides adequate representation of the intake data, and is easier to describe functionally. The infiltration function defining the "typical" curve is:

$$z = 4.27 t^{0.64} \quad , \quad (9)$$

where z = depth infiltrated (mm)
 t = intake opportunity time (min).

Equation (9) was also used to develop the initial design results presented earlier.

Advance and recession data were collected at 30-m stations along the irrigated run. These data along with infiltration opportunity times and the surface profile slope are presented in Figure 5. Since runoff data are not available, the advance and recession curves were extrapolated to their intersection in Figure 5. The imaginary extended length is seen to be about 260 m. Intake opportunity times for the imaginary extended length are included. An estimate of the actual average applied depth can now be determined. The inflow rate of 34 ℓ ps (1.2 cfs) was constant for the entire 88-min. duration. Therefore:

$$D_a = \frac{W_a}{WL} = \frac{QT}{WL} \quad (10)$$

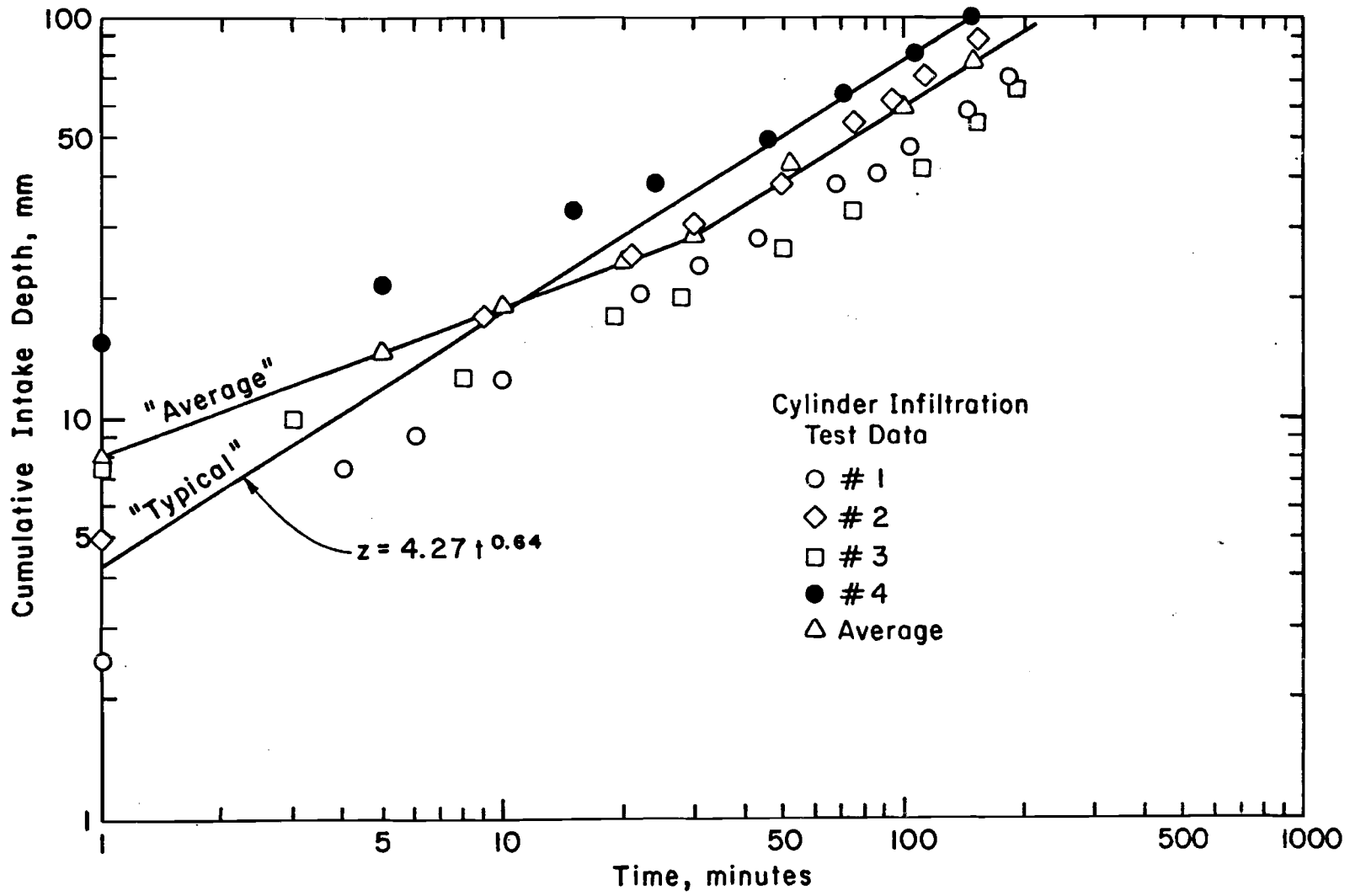

Figure 4. Cylinder intake data.

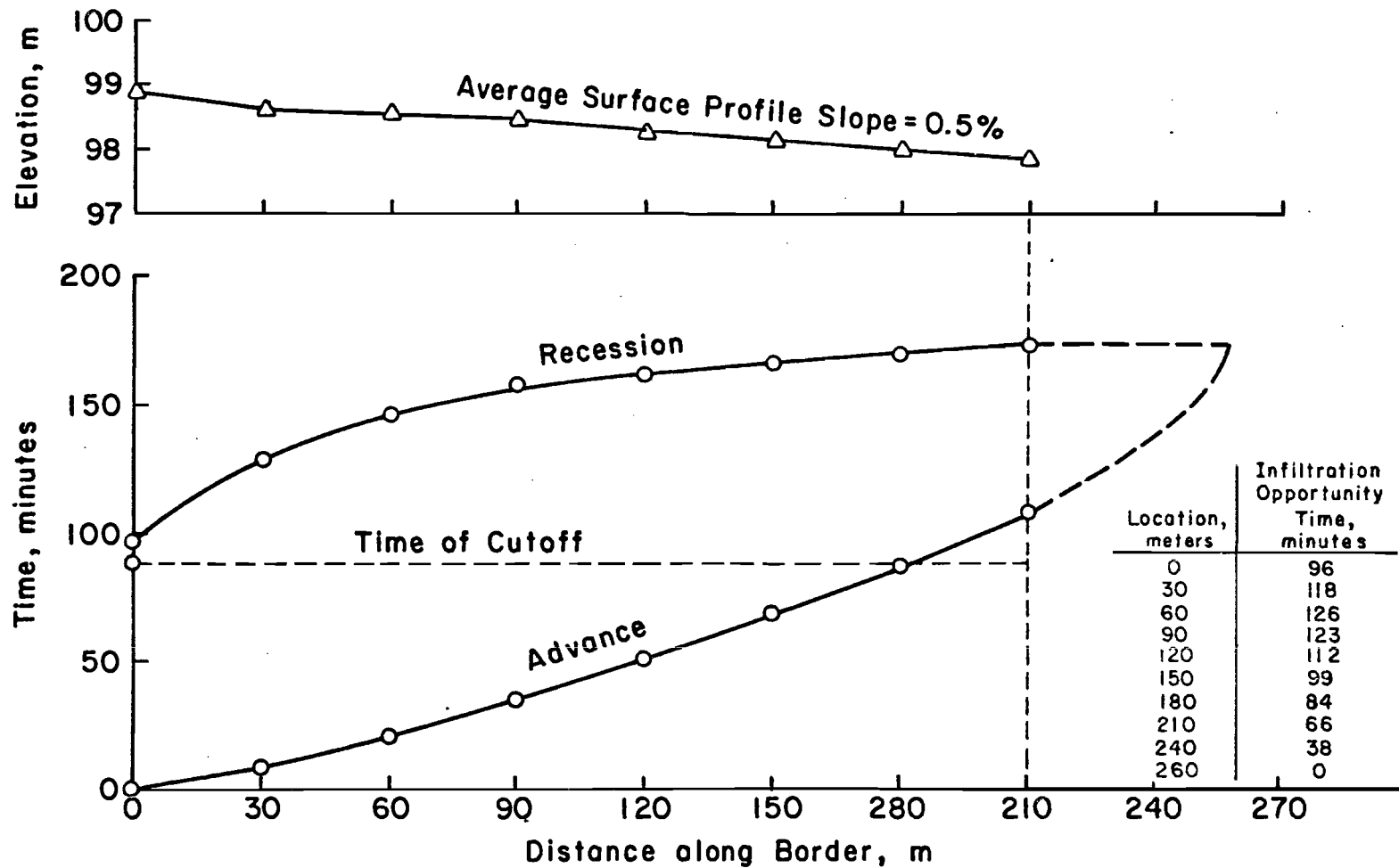

Figure 5. Advance/recession, surface profile curves and infiltration opportunity times.

1/26

$$D_a = \frac{(34 \text{ lps})(88 \text{ min})(60 \text{ x/min})\left(\frac{1 \text{ m}^3}{1000 \text{ l}}\right)}{(7 \text{ m})(260 \text{ m})} \left(\frac{1000 \text{ mm}}{1 \text{ m}}\right)$$

$$D_a = 99 \text{ mm}$$

This value can be used as a checkpoint for testing the adequacy of the infiltration function previously determined in predicting the average applied depth. The procedure is illustrated in Table 2. Equation (9) and infiltration opportunity times from Figure 6 are used to find infiltrated depths at stations along the run (actual plus extended length). The average depth for each 30-m reach is found. The last reach was only 15 m, thus the average depth there was determined proportionately to its length. The average applied depth for the entire wetted length as predicted by Equation (9) is calculated as 76.9 mm. This does not correspond with the actual average depth applied of 99 mm, as found earlier.

Adjustment of the infiltration function is necessary. The procedure for doing this is illustrated graphically in Figure 6. The "typical" curve represented by Equation (9) is shifted upwards in Figure 6 keeping the slope of the curve constant. The "adjusted" curve should have a slope equal to the "typical" curve and should pass through the point, where the depth equals 99 mm and the time equals the time at which the "typical" curve has a depth of 76.9 mm infiltrated. This time (using Equation (9)) is approximately 92 minutes. The intercept at unit time for the adjusted curve is approximately 5.48 mm. A numerical procedure for determining the functional relationship of the "adjusted" curve involves finding a new value for k in Equation (2), such that with $a = 0.64$ and $t = 92 \text{ min}$, z will equal 99 mm:

$$\begin{aligned} k &= z \div t^a \\ k &= 99 \div 92^{0.64} \\ k &= 5.48 \end{aligned}$$

Thus, the "adjusted" infiltration curve is represented by:

$$z = 5.48 t^{0.64} \tag{11}$$

where z = cumulative infiltrated depth (mm)
 t = time (min).

Table 2. Check on infiltrated depths and total applied depth predicted by "typical" infiltration function and "adjusted" infiltration function (after Merriam and Keller, 1978).

Station (m)	0	30	60	90	120	150	180	210	240	260
Opportunity Time (min)	96	118	126	123	112	99	84	66	38	0
Infiltration Depths (using Equation (9))										
Depth (mm)	79.3	90.5	94.3	92.9	87.5	80.8	72.8	62.4	43.8	0.0
Average Depth (mm)		84.9	92.4	93.6	90.2	84.2	76.8	67.6	53.1	0.5 (21.9)
Average Depth on 260 mm = $653.7/8.5 = 76.9$ mm										
Infiltration Depths (using Equation (11))										
Depth (mm)	101.7	116.1	121.1	119.2	112.3	103.7	93.4	80.0	56.2	0.0
Average Depth (mm)	108.9	118.6	120.2	115.8	108.0	98.6	86.7	68.1	0.5(28.1)	
Average Depth on 260 mm = $838.8/8.5 = 98.7$ mm										

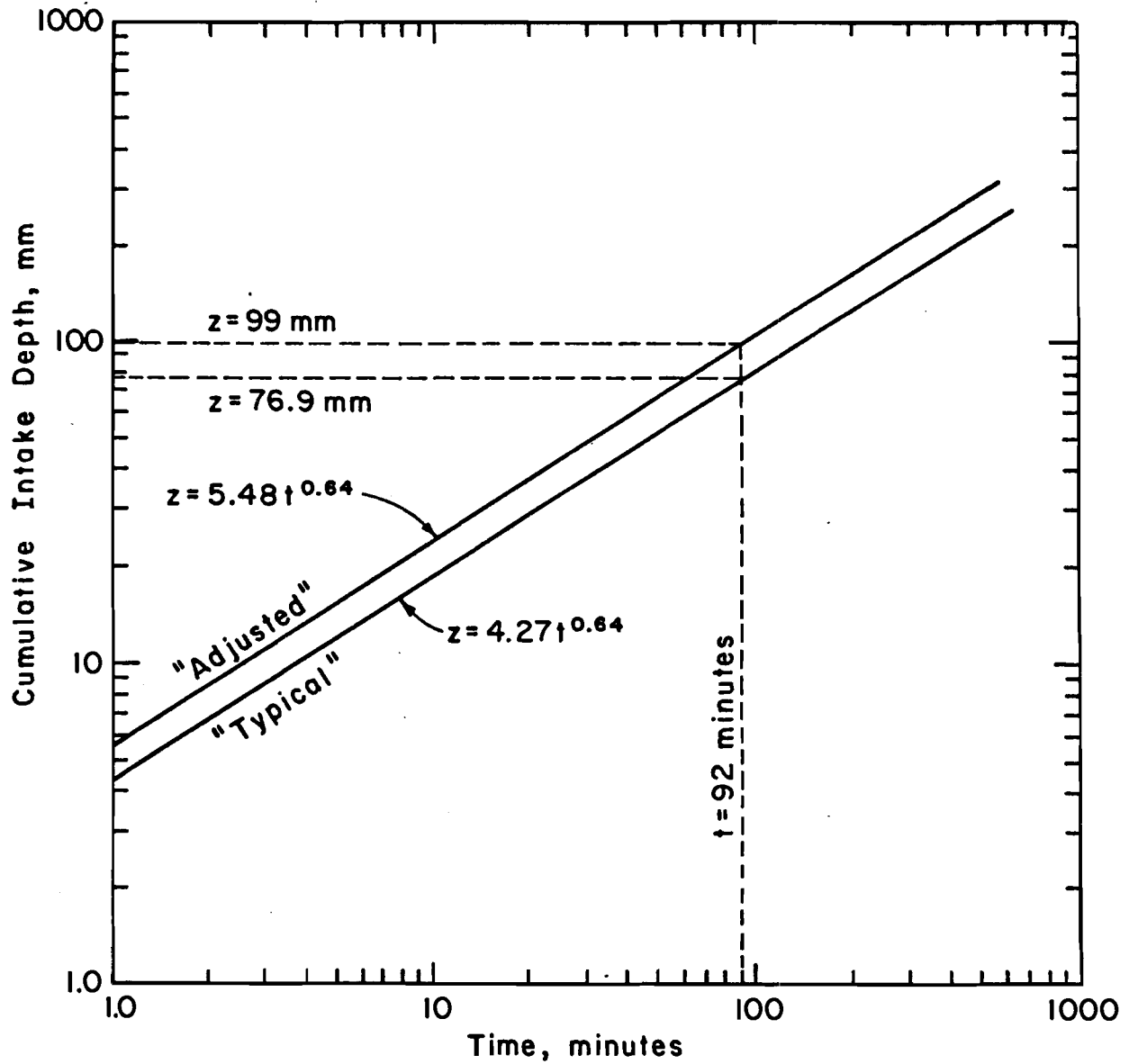

Figure 6. Illustration of adjustment of infiltration function.

A check on the adequacy of the "adjusted" curve is provided in the lower section of Table 2 using the same procedure as before. It is seen that Equation (11) adequately predicts the total average applied depth.

Results

The subsurface distribution of applied water as predicted by Equation (11) is plotted in Figure 7.

Each of the volumes associated with Figure 7 (as previously discussed) can be found by graphical integration of related areas of Figure 7. On a unit width basis (for border width of 7 m), they are as follows:

$$\begin{aligned} \text{Volume applied, } W_a &= 25.6 \text{ m}^3/\text{m} \\ \text{Volume runoff, } W_u &= 2.7 \text{ m}^3/\text{m} \\ \text{Volume infiltrated, } &22.9 \text{ m}^3/\text{m} \\ \text{Volume required, } W_r &= 15.7 \text{ m}^3/\text{m} \\ \text{Volume stored, } W_{rz} &= 15.7 \text{ m}^3/\text{m} \\ \text{Volume deep percolated, } W_p &= 7.2 \text{ m}^3/\text{m} \\ \text{Volume deficit, } W_{df} &= 0.0 \text{ m}^3/\text{m} \end{aligned}$$

Each of these volumes can be converted to an average depth by dividing by the border length of 240 m. Utilizing the above volumes, the performance parameters for this irrigation are determined using Equations (4) through (7).

$$\begin{aligned} \text{Water application efficiency, } E_a &= \frac{W_{rz}}{W_a} \cdot 100 & (4) \\ &= \frac{15.7}{25.6} \cdot 100 \\ &= 61.4\% \end{aligned}$$

$$\begin{aligned} \text{Water requirement efficiency, } E_r &= \frac{W_{rz}}{W_r} \cdot 100 & (5) \\ &= \frac{15.7}{15.7} \cdot 100 \\ &= 100\% \end{aligned}$$

$$\begin{aligned} \text{Tailwater ratio, } R_t &= \frac{W_u}{W_a} & (6) \\ &= \frac{2.7}{25.6} \\ &= 0.11 \end{aligned}$$

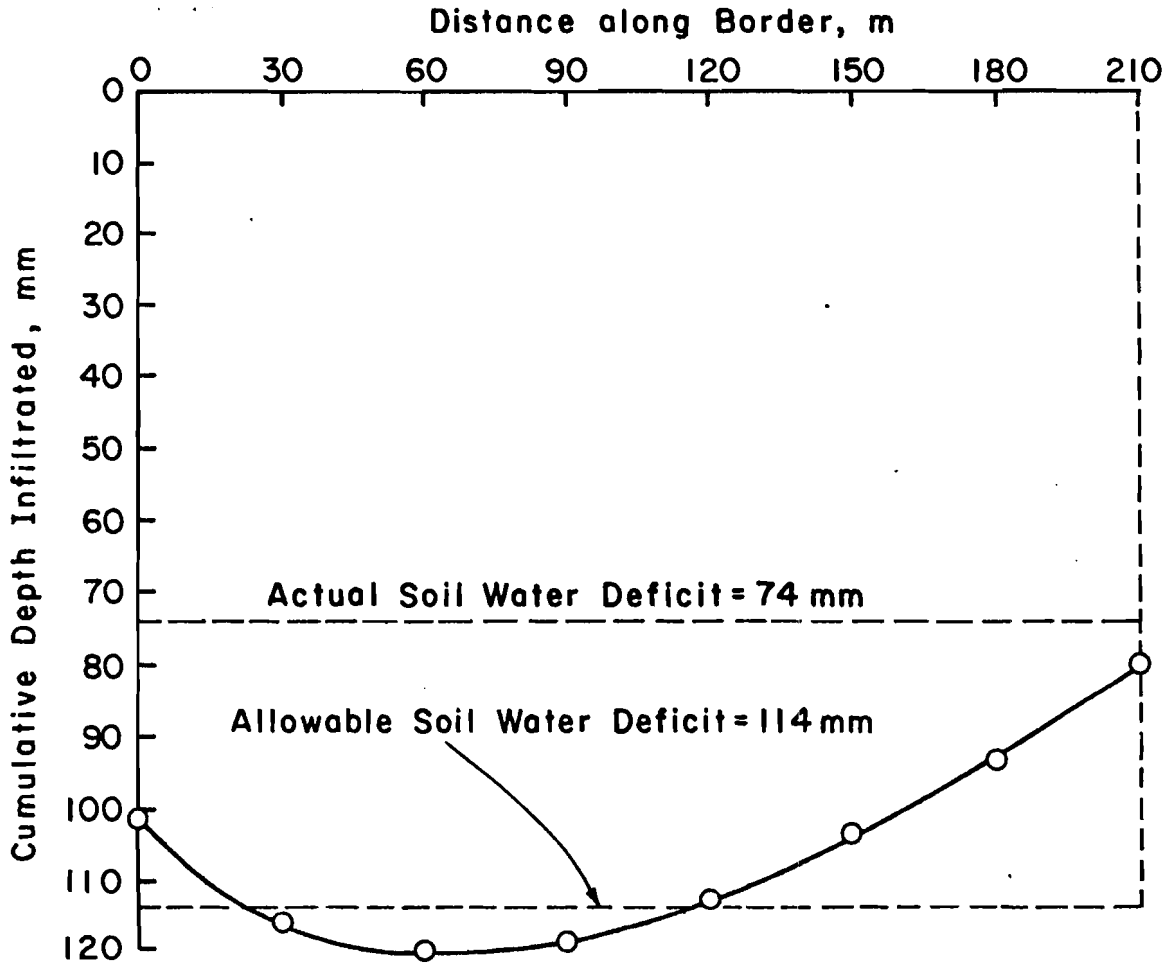

Figure 7. Subsurface distribution of applied water.

$$\begin{aligned}
 \text{Deep percolation ratio, } R_p &= \frac{W_p}{W_a} & (7) \\
 &= \frac{7.2}{25.6} \\
 &= 0.28
 \end{aligned}$$

The uniformity of water application is illustrated in Figure 8.

Table 3 presents a comparison of the suggested design with the system as it was operated for this irrigation. The expected runoff and deep percolation for the design are not available.

Table 3. Comparison of design and current operation.

Parameter	Design	Current Operation
Unit width stream, $\ell/s\text{-m}$	4.31 (0.0464 cfs/ft)	4.83
Time of application, min	118.0	88.0
Border strip width, m	7.9 (26.0 ft)	7.0
Design depth or requirement, mm	114.0 (4.5 in.)	74.0
Average depth applied, mm	142.5 (5.61 in.)	119.9
Water application efficiency, %	80.0	61.4
Water requirement efficiency, %	--	100
Tailwater ratio, dec.	--	0.11
Deep percolation ratio, dec.	--	0.28

CONCLUSIONS

As a result of the evaluation, and comparison of the results to the suggested design, the following conclusions are made:

1. Obviously, the farmer irrigated too soon, i.e., at a smaller requirement than suggested. Although he was aware of this and was trying to apply a lighter amount, he still overirrigated the entire field.

2. Using the entire available flow on a smaller strip width, the farmer was using a larger unit width stream. The smaller application time used must be an attempt at reducing the amount applied. At 80% design efficiency and a requirement of 74 mm (2.9 in.), design equations yield an application time of approximately 68 minutes for this larger unit width stream. For the given field length this may be too short, since the distance of advance for this time is about 150 m (Figure 5). Poor distribution and underirrigation of the lower end would probably result.

3. The anticipated advance curve for the design should be only slightly steeper than in Figure 5 due to the offsetting effects of greater application time, but higher initial intake rate of the drier soil. The anticipated recession curve should be slightly steeper at the lower end and shifted upwards by an amount equal to the increase of application time, compared to Figure 5. Thus, the expected result if the system were operated according to design would be a more uniform application of water, with the upper end being slightly overirrigated and the lower end being slightly underirrigated.

4. For the border strip width currently in use, the farmer could use the larger unit width stream and decrease the application time to around 106 minutes and expect a value of E_a near 80%. The resulting irrigation would most likely be less uniform, however.

5. The nonuniformity in slope for the first 90 m probably causes the recession curve to be steeper in that section. The first 30 m, being much steeper, would cause a short lag time; and then the next, flatter 60-m section would cause the recession to slow down. The advance is also slowed down in the 30-m station to 90-m station section (refer to Figure 5). If this section were graded to the slope of the remainder of the field, the advance and recession curves should be more "parallel" and the amount of overirrigation in that section reduced.

6. The large amount of deep percolation is a result of irrigating too soon. The amount of runoff is about right, however, indicating the farmer had about the correct inflow time. An efficient irrigation would most likely be impossible for the 210 m border, the given soil water deficit and the available stream. Either a very non-uniform irrigation would result, with the requirement at the upper end just being met; or there would be a large amount of runoff on what have to be very narrow borders (so that the unit width stream would be large enough for the desired advance time).

RECOMMENDATIONS

1. The farmer should attempt to adhere to an irrigation schedule in which the design depth of 114 mm (4.5 in.) is applied at each irrigation. Obviously, however, seasonal changes in crop requirement and infiltration rate would have to be taken into account.

2. Land leveling to obtain a more uniform grade in the direction of irrigation would increase the uniformity of the water application. In

particular, the overirrigation occurring at the upper end of the border would be reduced.

3. The combined effects of the first two recommendations would yield high values for E_a and E_r . Also, it is pointed out, that runoff losses from the border could be effectively reduced through the use of a tailwater reuse system.

4. The farmer should not deviate from an irrigation schedule in which he applies 114 mm (4.5 in.) at each irrigation. The implication of operating at lower values of design depth for the given available flow rate and border dimensions is that the efficiency and uniformity of water application would be reduced. Otherwise, increased flexibility in the timing and rate of water delivery is necessary to obtain a specific unit width stream for a particular design depth, design efficiency and application time.

5. Using the 7-m (23-ft) width borders rather than the design recommended 7.9-m (26-ft) width results in a larger unit width stream when the full available flow is utilized. This reduces the application efficiency. Assuming the other design parameters had been used with this unit width stream, a reduction in efficiency from the design efficiency is expected. The farmer could use a slightly smaller application time than the design and still achieve good results since the deviation in border widths was small. The best alternatives are to reduce the supply rate to the field or increase the width to 7.9 meters.

EQUIPMENT LIST AND SUGGESTED DATA FORMS

Equipment

The equipment needed for a detailed evaluation of a border irrigation system is:

1. Engineer's level and rod for reading ground surface elevations.
2. A measuring tape for locating stations and measuring border dimensions.
3. Laths or stakes, hatchet and crayon for marking stations.
4. Instrument for measuring time (wristwatch with a second hand).
5. Equipment for collecting soil samples to determine water content.
 - a. Soil auger or probe to take soil samples.
 - b. Soil cans with tight-fitting lids.
6. Equipment for determining bulk density.
7. Cylinder infiltrometers (up to 6 sets).

8. Device for measuring the water level in cylinder such as a hook or staff gauge.
9. Equipment for installing cylinders.
 - a. Metal plate or a heavy timber.
 - b. Sledge hammer.
10. 3-mil plastic sheeting or other waterproof membrane.
11. Buckets for hauling water.
12. Shovels.
13. Devices for measuring flow such as Parshall or cutthroat flumes, calibrated siphons, weirs or flow meters.
14. Pencils, clipboards and data forms.

Data Forms

Data forms for the following data sets are provided:

Soil Water Content Data

Bulk Density Data

Cylinder Infiltrimeter Data

Water Advance/Recession Data

Flow Rate Data

Farm and Field Data

APPENDIX A

RECONNAISSANCE QUESTIONNAIRE

1. Farmer operation and management

How does the farmer decide when to irrigate?
What is his irrigation frequency? How does it change during the season?
How does he decide how to irrigate?
How does he decide how much water to apply?
Does the farmer know the total flow rate available to him?
What are the farmer's operating hours?
Does he irrigate at night?
How does he decide how long to irrigate a field?
How long does he irrigate a field?
Does the farmer have any problems with the system?
What are his cultivation and tillage practices?
Does he irrigate more than one border strip at once?

2. Water supply

What are the sources of available water?
Is the delivery station (point of diversion to farm) a problem, i.e., high losses, etc.?
Is the on-farm distribution system a problem (i.e., too many in-field channels, high losses, etc.)?
What is the flow rate of each source of water?
When is each source available and for how long?
Is the frequency of delivery and available head a problem?
What is the water quality?
How is the water delivered to each field?

3. Crop characteristics

What are the crops being grown?
What are the respective planting dates?
What cropping patterns, if any, have been followed?
Does the farmer have any major problems in crop production?
What are the major inputs? Potential yield?
What is his expected yield? Average yield in area?
Any obvious physical symptoms of problems?

4. Physical characteristics

Does the farmer know the field dimensions?
Does he know the slope and cross-slope (if any)?
Has the field been leveled to a uniform slope?
If yes, when? If no, why not?
What provisions, if any, are made for surface runoff?
Does runoff leave the farm or is it used again somewhere on the farm?
What is the border spacing and how did the farmer decide on that spacing?
What is the method of diverting water into each border?

5. Soil survey

Does the farmer know the soils on his farm?

Does he know of any trouble spots (i.e., very light or heavy soils or salinity problems)?

6. Water table

Does the farmer know the groundwater level?

Does he feel it is a problem?

Is surface/subsurface drainage provided? If so, where?

APPENDIX B
SOIL MOISTURE MEASUREMENT CONSIDERATIONS

Basic guidelines to aid the evaluator in establishing procedures for sampling (where to samples, how many samples, etc.) are discussed. Plans will be needed to determine when, where and how much to sample for soil parameters such as field capacity, wilting point, bulk density, water content and infiltration as discussed in the text. It is recalled that a minimum of three replications of samples is called for in all cases to obtain a simple average. The following discussion is intended to provide a means of determining when more samples should be collected (and how many more) to increase the precision of the results and also to illustrate simple tests which can be used to interpret the results. Garcia (Appendix A, 1978) has presented a basic treatment of the statistical analyses of measurements. These include measures of central tendency, such as mean; measures of variability, such as the standard deviation; and simple statistical inference based on these population parameters such that for a given level of probability an interval of values which encloses the true value of a parameter is estimated.

Several studies have focused on determining the variability of soil sampling for water content (Black et al., 1965; Reuss et al., 1975; Staple and Lehane, 1962; Hewlett and Douglass, 1961). Each of these studies presents results of site studies including means and standard deviations of sampling and extrapolation of these results to methods of estimating numbers of samples required for given levels of precision. The problems with such approaches is that it is necessary to know beforehand the variability of water contents to be expected in a field such that the number of samples or replicated samples to collect to obtain a confidence interval for the mean at a given precision (level of probability) can be determined. It is difficult to estimate the combined effects of sampling errors, possible sampling bias, and the variation of soil properties in a field (let alone the individual effects). At any rate, generalizations are made such as: requiring 30 or more samples per treatment to provide fair assurance that the least significant difference between the means of two treatments be less than 0.5 inch of water (Staple and Lehane, 1961). It should be obvious that

given a certain level of variability in a given sampling plan, the precision with which a true value is estimated will increase as the number of samples taken increases. However, this is even further magnified where one is trying to estimate the difference between two true values. For instance, Reuss et al. (1975) presented results which showed that 95% confidence intervals for before and after irrigation water contents in a profile could be estimated as 9.50 ± 0.37 inches and 12.00 ± 0.61 inches, respectively. These were quite acceptable for the number of cores taken: five. However, for the difference of 2.5 inches the precision is ± 0.71 inches or approximately $\pm 28\%$ of the value which was being estimated. This was unacceptable, and to increase the precision with which the difference is estimated the number of samples to collect both before and after irrigation is more than 60. This assumes the variability or error variance of sampling is a constant.

Two useful tools for analyzing sets of samples for significant differences are one-way and two-way analysis of variance tests. For instance, if a soil survey shows nonuniform soils in the field being studied, but significant differences in infiltration rates through the field are not suspected, a one-way analysis of variance of several sets of replicated tests would statistically determine if significant differences between locations are present. Similarly, a two-way analysis of variance can be used to check on differences between replications at a sampling location and on differences between sampling locations.

In all instances, it should be remembered that replications (minimum of three) are required to establish an average. If soils are uniform, three cores in the entire field may be all that are necessary, however, more may be desired to increase precision. When soils are nonuniform, replications (minimum of three) in each major soil type are necessary to establish the mean for that soil type. More samples will increase the precision. A one-way analysis of variance will determine if significant differences between the estimated means exist. Tradeoffs in precision and costs (time and effort of the evaluator) occur. In general, the best design to use is the one that provides the maximum precision at a given cost (effort) or that provides a specified precision (error) at the least cost (Black et al., Chapter 5, 1965).

BIBLIOGRAPHY

- Black, C. A., D. D. Evans, J. L. White, L. E. Ensminger, and F. E. Clark, editors. 1965. Methods of Soil Analysis, Part 1, Monograph Series No. 9, American Society of Agronomy, Inc., Madison, Wisconsin.
- Egypt Water Use and Management Project. 1979. Problem Identification Training Manual for On-Farm Irrigation Systems, Volume II. Egypt Water Use and Management Project, Colorado State University, Fort Collins, Colorado.
- Garcia, I. 1978. Soil-Water Engineering Laboratory Manual. Department of Agricultural and Chemical Engineering, Colorado State University, Fort Collins, Colorado.
- Hagan, R. M., H. R. Haise, and T. W. Edminister, editors. 1967. Irrigation of Agricultural Lands. Monograph Series No. 11, American Society of Agronomy, Inc., Madison, Wisconsin.
- Hart, W. E. 1961. Overhead Irrigation Pattern Parameters. Agricultural Engineering, 42(7):354-355.
- Hart, W. E. 1975. Irrigation System Design. Department of Agricultural and Chemical Engineering, Colorado State University, Fort Collins, Colorado.
- Hewlett, J. D. and J. E. Douglass. 1961. A Method for Calculating Error of Soil Moisture Volumes in Gravimetric Sampling. Forest Science 7(3):265-272.
- Merriam, J. L. and J. Keller. 1978. Farm Irrigation System Evaluation: A Guide for Management. Agricultural and Irrigation Engineering Department, Utah State University, Logan, Utah.
- Ley, T. and W. Clyma. 1980. SCS Furrow Irrigation Design. Notes for AE535. Department of Agricultural and Chemical Engineering, Colorado State University, Fort Collins, Colorado.
- Ley, T. and W. Clyma. 1980. Design of Graded Border Irrigation Systems. Notes for AE535. Department of Agricultural and Chemical Engineering, Colorado State University, Fort Collins, Colorado.
- Reuss, J. O., S. A. Qureshi, and N. M. Chaudhry. 1975. Evaluation of Errors in Gravimetric Determination of Soil Water, Appendix 1. Annual Technical Report, Water Management Research Project, Colorado State University, Fort Collins, Colorado.
- Staple, W. Y. and J. J. Lehane. 1962. Variability in Soil Moisture Sampling. Canadian Journal of Soil Science, Vol. 42, February, pp. 157-164.
- USDA. 1974. Border Irrigation. National Engineering Handbook, Section 15, Chap. 4, Soil Conservation Service, U.S. Department of Agriculture.
- USDA. 1978. Draft of Furrow Irrigation. National Engineering Handbook, Section 15, Chap. 5, Soil Conservation Service, U.S. Department of Agriculture.