

P.D. 1341L 333

**FINAL REPORT
PROJECT A-2352
AID/afr-C-1518**

**PYROLYTIC CONVERSION OF WASTE MATERIALS:
DEMONSTRATION IN GHANA**

**By
F. J. Malvar, Project Director
J. E. Jacobson
R. J. Kovac
K. A. Yeboah***

(*Building and Road Research Institute, Kumasi, Ghana)

**Prepared for
U.S. AGENCY FOR INTERNATIONAL DEVELOPMENT
BUREAU FOR AFRICA
OFFICE OF SCIENCE AND TECHNOLOGY
WASHINGTON, D.C., 20523, U.S.A.**

**Contracting through the
GEORGIA TECH RESEARCH INSTITUTE
ATLANTA, GEORGIA 30332, U.S.A.**

October 1981

GEORGIA INSTITUTE OF TECHNOLOGY

**A Unit of the University System of Georgia
Engineering Experiment Station
Atlanta, Georgia 30332**

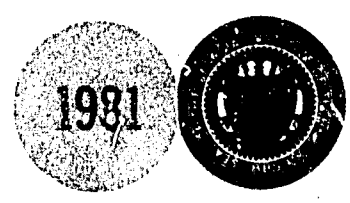

ROUTING AND TRANSMITTAL SLIP

Date

TO: (Name, office symbol, room number, building, Agency/Post)	Initials	Date
1. Paul Weatherly, St/EM		
2. <i>Ru 306 G</i>		
3.		
4.		
5.		

Action	File	Note and Return
Approval	For Clearance	Per Conversation
As Requested	For Correction	Prepare Reply
Circulate	For Your Information	See Me
Comment	Investigate	Signature
Coordination	Justify	

REMARKS

Pyrolysis Demonstration Project in Ghana (698-0135)

You may already be familiar with the Georgia Institute of Technology's evaluation of this project. The evaluation (final version arrived a couple of days ago) was given to us in draft last fall in draft. It was weak, especially the economic portion, which reached more positive conclusions about the viability of the project than the facts seemed to justify. We asked Gene Ellis of SERI to suggest ways to improve it, and some of these were incorporated into the present version.

We now have 100 copies of this version. We would appreciate your reviewing the report and giving us your views on its conclusions. We plan to send a copy to all AFR USAIDs, and any other addressees you may suggest. **DO NOT use this form as a RECORD of approvals, concurrences, disposes, clearances, and similar actions**

FROM: (Name, org. symbol, Agency/Post)	Room No.—Bldg.
Mark Wade, AFR/SDP	Rm 2480 NS
	Phone No.
	x 21808

5010-102

U.S. G.P.O. 1980-311-155/4

OPTIONAL FORM 41 (Rev. 7-76)
 Prescribed by GSA
 FPMR (41 CFR) 101-11.206

suggest, together with whatever cautionary statement
may seem appropriate.

You may wish to talk to Kevin Mullally for more
details about this enterprise.

**PYROLYTIC CONVERSION OF WASTE MATERIALS:
DEMONSTRATION IN GHANA**

By

**F. J. Malvar, Project Director
J. E. Jacobson
R. J. Kovac
K. A. Yeboah***

(*Building and Road Research Institute, Kumasi, Ghana)

**Project A-2352
AID/afr-C-1518**

Prepared For

**U.S. Agency For International Development
Bureau For Africa
Office Of Science And Technology
Washington, D.C., 20523, U.S.A.**

**Contracting through the
Georgia Tech Research Institute
Atlanta, Georgia 30332, U.S.A.**

**International Programs Division
Technology Application Laboratory
Engineering Experiment Station
GEORGIA INSTITUTE OF TECHNOLOGY
October 1980**

Table of Contents

	Page
Acknowledgements	i
Summary	ii
1.0 INTRODUCTION	1
1.1 Background	1
1.2 Pyrolysis	3
1.3 Project Goals	5
1.4 Organic Waste Availability in Ghana	6
2.0 PROJECT ACTIVITY	17
2.1 Field Survey	17
2.2 Project Definition and Site Selection	18
2.3 Project Design and Fabrication	19
2.4 Construction of the Four-Convertors Integrated Pyrolysis System	28
2.5 Performance Testing and Demonstration	29
3.0 PYROLYTIC CONVERTOR DESIGN AND PROCESS DESCRIPTION	30
3.1 Convertor Components	30
3.2 Process Description	34
4.0 PROJECT RESULTS	35
4.1 Mechanical Considerations	36
4.2 Process Operations	37
4.3 Product Yields	38
5.0 ECONOMIC ANALYSIS	40
5.1 Pecuniary Costs and Benefits	40
5.2 Interpretation of Benefit-Cost Calculation	51
5.3 Benefit-Cost Evaluation for Private Industry	53
5.4 Benefit-Cost Evaluation for Government	53
5.5 Socio-Economic and Cultural Feasibility	56
5.6 Economic Conclusions	56
6.0 CONCLUSIONS AND RECOMMENDATIONS	57
6.1 Conclusions	57
6.2 Recommendations	58
7.0 APPENDICES	
Appendix A - Engineering Drawings and Bill of Materials	60
Appendix B - Operations and Maintenance Manual	72
Appendix C - Test Data	85
Appendix D - Inventory of Spare Parts	116
Appendix E - Chronological History of the Project	119
Appendix F - Proposed Pyrolytic Convertor Social Soundness Analysis	121
Appendix G - Calculation of Air to Feed Ratio	141
8.0 REFERENCES	145

Acknowledgements

This project extended through a rather long period of time and many people were involved in it. Trying to mention all the people that contributed to the project would be an impossible task.

During the period of our involvement in the project we benefited from the support of Mr. Robert MacAlister AID/Washington, Mr. Irving Coker, Director of AID/Ghana and Mr. John Cooper, Chief of OST. From the Building and Road Research Institute a number of persons cooperated in this project, among them, Dr. Amoono-Niezer Acting Director and Mr. Ocloo.

Special thanks to Dr. John Powell, Director of the Technology Consultancy Centre, whose support in the construction and development phase of this project was crucial, who in the development and adaptation of this system readily gave his invaluable inputs and who during the construction phase always gave us top priority so as to expedite the project. Mr. Kevin Davis and Mr. Daniel Chekou also of TCC, many thanks, for their interest and help in the project.

Summary

Pyrolysis, by rigorous definition, is the thermal decomposition of organic (carbonaceous) materials in the absence of free or added oxygen. Cellulosic and lignocellulosic materials, including forestry products and wastes (sawdust, shavings, bark, etc.) and agricultural products or residues (ground nut hulls, rice hulls, corn stover) contain oxygen which is bonded into, and forms an integral part of the compound. For example, some typical analyses of wood show an oxygen content of 36% to 38% on a dry basis.

In recent years, the commonly accepted definition of pyrolysis has been modified to allow the addition of oxygen, as long as the quantity of oxygen added is less than the stoichiometric amount required for complete combustion. Redefined, pyrolysis is a process which may have one or more than one distinct reaction zones, where oxygen may be added, with the limitation that in at least one reaction zone thermal decomposition occurs in the absence of oxygen.

Pyrolysis has been considered as an efficient method of converting forestry wastes and agricultural wastes into valuable products. At the same time pyrolysis is an adequate means of cleanly disposing of waste products that are creating pollution problems, if not at the very least nuisance problems. This process generates three products, a char, a pyrolytic oil and a gaseous fraction. In less developed countries where there is low labor costs or unemployment, adequate manpower availability, and an abundance of forestry or agricultural waste products, gathered in modest quantities but spread uniformly throughout the country, the need exists for a small-scale, labor intensive pyrolytic convertor system.

In 1976 the Agency for International Development (AID) contracted with the International Programs Office (IPO) of the Engineering Experiment Station (EES) of Georgia Tech to determine the feasibility of pyrolytic conversion of agricultural and forestry waste in Ghana. Based on the results of this feasibility study AID contracted with IPO to demonstrate the feasibility of the pyrolysis process in Ghana in December 1977.

The goal of the project in Ghana was to design and implement a pilot demonstration project to test the findings of the feasibility study, and then to design and demonstrate successfully, a small-scale, labor intensive pyrolysis system, to be located near a potential pyrolysis products user.

Many problems plagued the construction and testing of the system from its conception. The design of the system had to be modified and adapted until the expected results were met. This, added to the unavailability or scarcity of parts, equipment, and lack of adequate transportation in the country made the pyrolysis project a great deal more difficult and expensive than was initially estimated.

The convertor system has the following major components; four reactors, each one with an input airflow, a stirrer, a gas filter, condensing unit for oil extraction, and a char deposit/removal apparatus. Each reactor is connected to a manifold that feeds gas to two feedstock dryers. This system operated in a self sustaining, batch/continuous mode, under partial oxidation.

The results of the testing, which extended for over two and half years, improved with increasing experience, and the final yields were very satisfactory. The system is producing quality char, pyrolytic oil and gas, in quantities that exceeded all expectations.

The cost of this project does not reflect the true cost of a system which would be built on this design. It would not include all that was spent in the development phase of the project. A similar system can now be built for much less. It is our estimate that a system could be set up for between \$75,000 and \$85,000, and that the annual value of the outputs would exceed \$400,000 at 1980 prices.

1.0 INTRODUCTION

1.1 Background

Pyrolysis has been considered as an efficient method for converting forestry wastes and agricultural wastes into valuable products. At the same time pyrolysis is an adequate means of cleanly disposing of waste products that are creating pollution problems, if not at the very least nuisance problems. Georgia Tech has extensive and varied experience with the design and operation of pyrolysis units. GIT has studied and demonstrated the use of pyrolysis in several pilot plants (with capacities ranging from 500 lb. per hour to 1,500 lb. per hour -- dry basis) on the campus in Atlanta, Georgia. These systems have operated using peanut hulls, various nut shells (such as pecan or walnut), sawdust, bark, bark-sawdust mixtures and wood chips from a number of species of both soft woods and hardwoods. The GIT staff has participated in the design, construction, and operation of a 100 ton per day commercial plant processing wood wastes. These and other pyrolytic systems under development have been designed for use in industrialized nations. In less developed countries where there was low labor costs or unemployment, adequate manpower availability, and an abundance of forestry or agricultural waste products, gathered in modest quantities but spread uniformly throughout the country, the need existed for a small-scale, labor intensive pyrolytic converter system.

To address this need the Agency for International Development (AID) in 1976 contracted with the International Programs Office (IPO) of the Engineering Experiment Station (EES) of Georgia Institute of Technology to determine the feasibility of pyrolytic conversion of agricultural and forestry wastes in Ghana. The feasibility study,^{1/} designated as Project A-1823, was completed in July 1976.

In November 1977, IPO began preliminary design work on a small-scale, labor intensive pyrolysis system. AID contracted with IPO to demonstrate the feasibility of the pyrolysis process in Ghana in December 1977. In collaboration with the Technology Consultancy Center (TCC) of the University of Science and Technology (UST) and the Building and Roads Research Institute (BRRI) in Kumasi, Ghana, IPO would design, build, test and evaluate a small-scale pyrolysis system. The pyrolytic converter system would produce char, pyrolytic oil and gas from one of the principal organic waste products found in Ghana.

GHANA

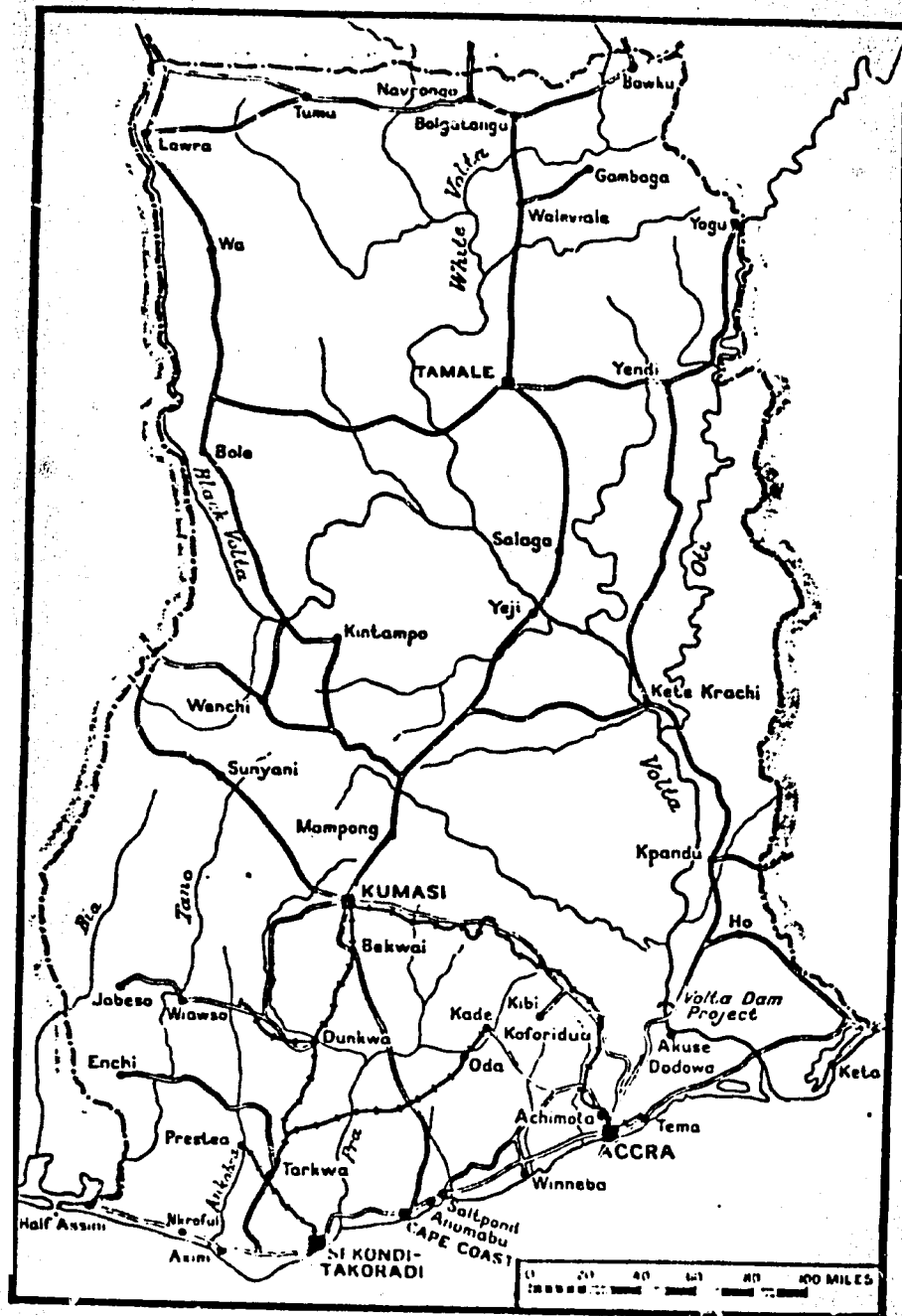

1.2 Pyrolysis

Pyrolysis, by rigorous definition, is the thermal decomposition of organic (carbonaceous) materials in the absence of free or added oxygen. Cellulosic and lignocellulosic materials, including forestry products and wastes (sawdust, shavings, bark, etc.) and agricultural products or residues (ground nut hulls, rice hulls, corn stover) contain oxygen which is bonded into, and forms an integral part of the compound. For example, some typical analyses of wood show an oxygen content of 36% to 38% on a dry basis.

In recent years, the commonly accepted definition of pyrolysis has been modified to allow the addition of oxygen, as long as the quantity of oxygen added is less than the stoichiometric amount required for complete combustion. Redefined, pyrolysis is a process which may have one or more than one distinct reaction zones, where oxygen may be added, with the limitation that in at least one reaction zone thermal decomposition occurs in the absence of oxygen.

The pyrolysis process generates three products: a char, a pyrolytic oil, and a gaseous fraction. This gas stream, in practice, contains some low boiling point compounds, water vapor, and non-condensable gases. Pyrolysis process temperatures may vary from about 800°F to 1800°F (427°C to 983°C). Short residence times and low process temperatures (800°F to 1000°F) favor char production. This char will have a high volatiles content, on the order of 25% to 30%. Some particles of feed material which were originally large in comparison with the average feed particle size may be charred on the outside but uncharred at the center. If this uncharred condition exists, the pyrolysis process is said to be producing "brown wood." Moderate processing temperatures (1000°F to 1200°F) cause a decrease in char yield, compared to lower processing temperatures, but an increase in oil yield. Maximum char yields of 40% to 45% have been accomplished with a corresponding oil yield in the area of 12%. As the char yield decreases to the range of 20% to 25% the oil yield increases to its maximum, which can range from 22% to 35% depending on the species of the feed material. For example, some tropical species such as eucalyptus and maleluca grandis exhibit a much higher maximum oil yield than many temperate zone species.

Higher processing temperatures (1400°F to 1800°F) and longer residence times favor gas production by causing devolatilization of the char, cracking of the oil and burning of the remaining char, which has a carbon content that may reach over 90%.

The yields and physical properties of the pyrolysis products: char, pyrolytic oil and gaseous fuel vary according to operating conditions and feed material. Generally, char yields ranging from several per cent (essentially ash) to about 45% can be produced. Heating values are normally within the range of 12,000 BTU/lb to 13,500 BTU/lb. Volatile content has been measured from about 3% to 30%.

Pyrolytic fluids, sometimes called pyrolytic oil, have been produced with moisture contents varying from about 3% to 75%. The latter substance is certainly not a usable pyrolytic oil. Pyrolytic oil yields may range from about 5% to 35%. Pyrolytic oils with a 5% to 25% moisture content are generally acceptable, with the desired moisture content in the range of 10% to 15%. Low moisture content pyrolytic oils exhibit higher viscosities which may cause handling problems. Adding some quantity of water lowers the viscosity, increases the ease of handling and seems to enhance combustion. The viscosity of the pyrolytic oil is also decreased by heating. A temperature of 125°F to 130°F is sufficient to provide for acceptable flow conditions. Heating values generally fall in the range of 9,000 BUT/lb. to 10,500 BUT/lb. The oils are acidic, the largest acid component being acetic acid, and are highly corrosive to mild or carbon steel. They are only very mildly corrosive to 304 stainless steel. The properties of pyrolytic oils have been shown to change with storage but the changes do not seem to be highly significant in the use of the oils as fuels.^{2/}

The pyrolytic oils are heat sensitive and tend to polymerize with reheating. Reprocessing temperatures for the pyrolytic oils in the range of 50°C to 75°C have been used.^{3/} Higher temperatures greatly enhance the polymerization reactions. The non-condensable gas fraction has a low BTU content. It cannot be economically compressed or stored. Generally the gas is used to supply an on site requirement for gas. If the moisture content of the feed material is greater than 10% a portion of the gas can be used to predry the feedstock. The heating value of the gas stream ranges from about 125 BTU/ft.³ to about 250 BTU/ft.³ These values are low due in part to the dilution effect of the nitrogen in the air added to the process.

1.3 Project goal

The goal of the series of projects in Ghana was to design and implement a pilot demonstration project to test the findings of the feasibility study, and then to design and demonstrate, successfully, a small-scale, labor intensive pyrolysis system, to be located near a potential pyrolysis products user. The site chosen was the property adjacent to the Building and Roads Research Institute (BRRI) brick kiln at Fumasua in Kumasi, Ghana. This particular project, designated A-2352-004, had a general goal of bringing to completion the pyrolysis demonstration project-Ghana. The itemized scope of work to satisfy the general goal is given below:

1. Assist the Ghanaians (TCC and BRRI) to complete construction of the 4-unit pyrolysis system at Fumasua/Kumasi.
2. Run operational system tests and make adjustments as required.
3. Train BRRI staff in the operational and maintenance procedures and oversee routine operation (2 shifts-5 days per week) for up to four weeks as the schedule permits.
4. Prepare an operations and maintenance manual.
5. Evaluate, in collaboration with TCC and BRRI, the the pyrolytic system during its test period; maintain records on system variables and changes during the test phase. The evaluation will include an appraisal of operating results and recommendations on the economic and social soundness of this system and of smaller systems utilizing locally available agricultural wastes.
6. Consult, as required, with the Ghanaian institution undertaking socio-economic studies on pyrolysis and its products.
7. Prepare a final report that includes the detailed final design, technical and economic analysis and discussions on all aspects of the project. The feasibility of pyrolytic conversion on an expanded basis in Ghana is to be examined and recommendations on commercialization made.

1.4 Organic Waste Availability in Ghana*

Agriculture and forestry are two major segments of the Ghanaian economy. The area of Ghana is about 92,100 square miles. The Ghanaian high forest in its natural state originally covered approximately 32,000 square miles. Much of that area has been denuded by farmers, with only scattered trees remaining to protect cocoa or food crop production. The remaining high forest area at present is roughly 10,700 square miles with 5,800 square miles of original high forest protected in government reserves and another 2,500 square miles of untouched forest land in the Western Region.^{4/}

Estimates by the Republic of Ghana-Central Bureau of Statistics show that in 1969 the total crop acreage under food production was about 2,769,000 acres. Total production from this acreage was estimated at 4,596,000 metric tons.^{4/} A significant acreage was also utilized for the production of cocoa. The wastes generated in all of the above areas are voluminous.

Many of the wastes are concentrated in fixed locations and require minimal effort in collection. Some of these materials are: sawdust, rice husks, coconut shells, and oil palm wastes. These wastes are produced in large quantities at processing plants, which are potential consumers of the fuels derived from these wastes. Other wastes which are not currently gathered and are produced in very large quantities could be collected if they were given some value. These wastes include: Timber slash, reforestation cuttings, cull trees, rice straw, and cocoa pods and husks.

Not all the wastes produced in Ghana can be practically used as alternate fuel sources. Some of the wastes are already used for other purposes. Some agricultural wastes, such as corn stalks, ground nut hulls, and cocoa pods are not included in the survey because they are important sources of domestic fuels to farmers and many present collection problems. In addition, the cocoa pod, which contains calcium, is an important fertilizer, and may be more valuable in that application.

*A survey of the potential sources of organic wastes for energy conversion was not included in the scope of work of this project. A survey was conducted as part of an earlier project, (in 1976) A-1823, a feasibility study. Relevant portions of that survey are included here for completeness.

The data presented below are the best estimates based on information provided by authoritative sources (mainly through personal interviews) in Ghana. Only those sources of wastes which were easily identified and had no practical uses at the time of the survey were considered. A summary of the agricultural and forestry wastes in Ghana which have high potential for collection for energy conversion, based on the results of the field study, are shown below:

<u>Waste Source</u>	<u>Quantity Generated (Tons/Year)</u>
Reforestation Wastes	1,079,700
Coconut Wastes	686,400
Rice Straw and Husks	517,700
Logging Wastes	403,00
Sawdust	25,500
Oil Palm Wastes	22,800
TOTAL	<u>2,735,100</u>

The weight of these wastes is given on a wet basis, using a moisture content of 50%. If all of the above materials were converted into charcoal and pyrolytic oil, 342,000 tons of charcoal and 273,000 tons of pyrolytic oil would be produced.

Six major kinds of agricultural and forestry wastes which were considered as potential raw materials for pyrolytic conversion were discussed in terms of volume, location, and methods of estimation.

1.4.1 Sawmill Wastes

Sawmills generate two kinds of waste. One is sawdust which is thrown away, piled, or used as landfill. The other is offcuts, such as trims, edges, short ends, and defects. Most of the offcuts are used as boiler fuel at the respective mill, for low-grade furniture material, or as fuel by the neighboring residents. Most sawmills would give the sawdust away at no charge if the recipient provided the transportation and labor.

The volume of sawdust generated by sawmills in eight major locations is estimated below.*

1. KUMASI

<u>No. of Saw Mills</u>	<u>Bags of Sawdust Generated Each Mill Per Month</u>	<u>Total Lbs. Per Each Mill Per Month @105 lbs/Bag</u>	<u>Total Lbs. Per Month</u>
4 Large	1,500	157,500	630,000
10 Medium	1,000	1,050,000	1,050,000
14 Small	500	52,500	735,000
<u>28 Mills</u>			<u>2,415,000</u>
Total Pounds Per Year	28,980,000 Lbs./Yr.		
Total Tons Per Year	14,490 Tons/Yr.		

2. TAKORADI

<u>No. of Saw Mills</u>	<u>Bags of Sawdust Generated Each Mill Per Month</u>	<u>Total Lbs. Per Each Mill Per Month @105 lbs/Bag</u>	<u>Total Lbs. Per Month</u>
1 Large	1,500	157,500	157,500
3 Medium	1,000	105,000	315,000
			<u>473,500</u>
Total Pounds Per Year	5,670,000 Lbs./Yr.		
Total Tons Per Year	2,835 Tons/Yr.		

3. MIM

<u>No. of Saw Mills</u>	<u>Bags of Sawdust Generated Each Mill Per Month</u>	<u>Total Lbs. Per Each Mill Per Month @105 lbs/Bag</u>	<u>Total Lbs. Per Month</u>
1 Large	1,500	157,500	157,500
Total Pounds Per Year	1,890,000 Lbs./Yr.		
Total Tons Per Year	945 Tons/Yr.		

*Based on data provided by the forest products Research Institute, University of Science and Technology, Kumasi, Ghana.

4. SAM REBOI

<u>No. of Saw Mills</u>	<u>Bags of Sawdust Generated Each Mill Per Month</u>	<u>Total Lbs. Per Each Mill Per Month @105 lbs/Bag</u>	<u>Total Lbs. Per Month</u>
1 Large	1,500	157,500	157,500
Total Pounds Per Year	1,890,000 Lbs./Yr.		
Total Tons Per Year	945 Tons/Yr.		

5. SEFWI-WIAWSO

<u>No. of Saw Mills</u>	<u>Bags of Sawdust Generated Each Mill Per Month</u>	<u>Total Lbs. Per Each Mill Per Month @105 lbs/Bag</u>	<u>Total Lbs. Per Month</u>
1 Large	1,500	157,500	157,500
Total Pounds Per Year	1,890,000 Lbs./Yr.		
Total Tons Per Year	945 Tons/Yr.		

6. ODA

<u>No. of Saw Mills</u>	<u>Bags of Sawdust Generated Each Mill Per Month</u>	<u>Total Lbs. Per Each Mill Per Month @105 lbs/Bag</u>	<u>Total Lbs. Per Month</u>
1 Medium	1,000	105,000	105,000
4 Small	500	52,500	210,000
			<u>315,000</u>
Total Pounds Per Year	3,780,000 Lbs./Yr.		
Total Tons Per Year	1,890 Tons/Yr.		

7. SUNYANI, BEREKUM, AND TEPA

<u>No. of Saw Mills</u>	<u>Bags of Sawdust Generated Each Mill Per Month</u>	<u>Total Lbs. Per Each Mill Per Month @105 lbs/Bag</u>	<u>Total Lbs. Per Month</u>
5 Small	500	52,500	262,500
Total Pounds Per Year	3,150,000 Lbs./Yr.		
Total Tons Per Year	1,575 Tons/Yr.		

8. NKANKAW

<u>No. of Saw Mills</u>	<u>Bags of Sawdust Generated Each Mill Per Month</u>	<u>Total Lbs. Per Each Mill Per Month @105 lbs/Bag</u>	<u>Total Lbs. Per Month</u>
6 Small	500	52,500	315,000
Total Pounds Per Year	3,780,000 Lbs./Yr.		
Total Tons Per Year	1,890 Tons/Yr.		

Total sawdust generated by the sawmills in the eight areas is estimated at 25,515 tons per year.

Transportation cost for sawdust was estimated at \$5.00 (\$4.35 --- \$1=\$0.87) per 1.5 tons of sawdust in a 3 ton truck within a 10 mile radius. The corresponding rate was estimated at 33 pesewas (\$0.29) per ton mile, in 1976. Since that time the scarcity of operable vehicles, increase in petrol costs, change in the value of money, etc., have caused the transportation charge to change to a flat rate of \$550 per truck per day, including driver and petrol costs (per BRRRI estimates August 1980).

1.4.2 Rice Straw and Husk

Within a 50-mile radius of Tamale, there are 165,000 acres of rice in cultivation. The yield ranges from about 1/3 ton per acre to 1.0 ton per acre. The average yield is 0.5 tons per acre.

The rice is harvested using combines. The rice straw is left in the field after harvesting. The rice straw could be baled for transport to a pyrolytic conversion plant.

Two major rice varieties are grown in the areas: IR5 and IR20. IR5 has a tall stalk, while IR20 has a shorter stalk. In order to estimate the volume of rice straw generated the following data was collected:*

Ratio of rice straw to rice yield by weight:

IR5:	7.5 to 1
IR20	5.5 to 1
IR5:	Grown on 1/3 of total acreage
IR20	Grown on 2/3 of total acreage

Rice straw volume generated per year:

IR5:	(165,000 acres)	(1)	(7.5)	(0.5 ton)	= 206,250 tons/yr.
		3	1	acre	
R20:	(165,000 acres)	(2)	(5.5)	(0.5 ton)	= 302,500 tons/yr.
		3	1	acre	

Total rice straw in Tamale area = 508,750 tons/yr.

It was assumed that 80% of the total rice straw volume was collectable, then 407,000 tons per year could be used for pyrolytic conversion.

There are three rice mills in the Northern region. Two are in Tamale; one is located in Yendi about 70 miles east of Tamale. Each mill processes 72,000 bags of rice per year at 82 kilograms per bag. The rice husk constitutes from 22% to 25% of the weight.

Rice husk estimates:

Tamale:

2 mills	<u>72,000 bags</u>	<u>82 Kg.</u>	<u>2.2 lbs.</u>	.23	=	5,974,848 lbs./yr.
	mill	bag	Kg.			2,987 tons/yr.

Yendi:

1 mill	<u>72,000 bags</u>	<u>82 Kg.</u>	<u>2.2 lbs.</u>	.23	=	2,987,424 lbs./yr.
	mill	bag	Kg.			1,494 tons/yr.

*Based on data provided by the Agricultural Research Station, Nyankpala, Ghana.

There are three rice mills in the Upper Region with the same capacities as those in the Northern region. Total rice husk generation from those mills was estimated at 4,480 tons per year.

TOTAL RICE STRAW AND HUSK

Rice Straw	508,750 Tons Per Year
Rice Husk	<u>8,960 Tons Per Year</u>
TOTAL	517,710 Tons Per Year

1.4.3 Logging Wastes

Logging is carried out in the high forest areas. The waste consists of limbs, off-cuts, butt trimmings, and defective trees. The waste volume was estimated by the Forestry Department, Accra, Ghana for the following years:

<u>Year</u>	<u>Million Cubic Meters</u>
1970	0.51
1971	0.53
1972	0.62
1973	0.68
1974	0.47
<u>AVERAGE</u>	<u>0.56</u>

The wood density in the high forest areas varies from 20 lbs./ft.³, to 62 lbs./ft.³, with a corresponding average density of 41 lbs./ft.³, or 658 Kg./M³ — (1 lb./ft.³ = 16.05 Kg./M³).

Logging waste estimates were:

$$\begin{aligned}
 560,000 \text{ M}^3 & \times \frac{658 \text{ Kg.}}{\text{M}^3} & = & 368,480,000 \text{ Kg./yr.} \\
 & & = & 810,656,000 \text{ Lbs./yr.} \\
 & & = & 405,328 \text{ Tons/yr.}
 \end{aligned}$$

1.4.4 Reforestation Wastes*

Ghana has carried out a reforestation program since 1971. Under this program bushes and non-commercial species of trees have been cut and cleared to allow planting of desirable species. Since 1971, an average of 6,000 to 7,000 hectares per year of land was cleared. The project was expected to take 20 years to complete. Under the program, the volume of wood available for clear-cutting is given below:

<u>Region</u>	<u>Wood Volume (ft³)</u>	
	<u>1971 to 1975</u>	<u>Avg. Volume/Yr.</u>
Ashanti and Brong-Ahafo	545,473,000	27,273,650
Eastern and Volta	76,366,000	3,818,300
Western and Central	327,284,000	16,364,200
Northern and Upper	54,547,000	2,727,350
TOTAL	1,003,670,000	50,183,000

Annual wood waste under the reforestation program:

$$50,183,500 \text{ ft.}^3 \times \frac{41 \text{ lb.}}{\text{ft.}^3} = 2,057,523,500 \text{ lbs./yr.}$$

$$= 1,028,762 \text{ tons/yr.}$$

The magnitude of forest wastes in Ghana is large. The quantity of wastes that can be collected economically is uncertain. The economics will be affected by (among other factors) size and design of the convertor (possibly the use of a mobile pyrolysis system), the plant location, and road conditions.

It should be noted that ⁷ three trunks and large limbs represent the major portion of the forest wastes. Since pyrolysis systems have thus far operated on feed material with a maximum particle size of 1-1/2" * 1" * 1/4", the trunks and limbs will probably have to be split and chipped or possibly even hogged before they are suitable as a feed material. Small limbs, twigs, and bushes, which can be easily chipped or hogged, also constitute a significant portion of forest wastes and may be more suitable as a pyrolytic feedstock.

*Estimates based on data from the Forestry Department, Accra, Ghana, and the Forest Products Research Institute, University of Science and Technology, Kumasi, Ghana.

1.4.5 Coconut Wastes

The land under coconut cultivation in Ghana is estimated at between 80,000 acres and 84,000 acres. Each acre contains approximately 60 to 70 trees, and each tree bears 50 coconuts per year, on the average. The average weight of a coconut is 6.82 pounds. The average weight of the components of a coconut are:

<u>Components</u>	<u>Kilograms</u>	<u>Pounds</u>
Husk	2.5	5.50
Water	0.3	0.66
Copra (Meat)	0.2	0.44
Shell	0.1	0.22
<hr/> TOTAL	<hr/> 3.1	<hr/> 6.82

The waste components of a coconut, the husk and the shell, average approximately 5.72 lbs.

Coconut waste estimates are:

$$\begin{array}{r} 80,000 \text{ acres} \quad \underline{60 \text{ trees}} \quad \underline{50 \text{ nuts}} \quad \underline{5.72 \text{ lbs.}} = 1,372,800,000 \text{ lbs./yr.} \\ \text{acre} \quad \text{tree} \quad \text{nut} \quad \text{nut} \quad = \quad 686,400 \text{ tons/yr.} \end{array}$$

The Asiamma-Nzima and Winneba areas are the major coconut-producing areas. Coconut shells are currently exported to Yugoslavia for the production of activated carbon.

1.4.6 Oil Palm Wastes

The oil palm plantations at Prestea and Sese represent the two major locations for which production data are available. The distance between the two locations is about 12 miles. The total acreage at Prestea is 10,974 acres, at Sese, 8,228 acres for a combined acreage of 19,202 acres.

Oil palm yield, on the average, is estimated at 2 tons/acre of bunches in this area. The distribution of the components is shown below:

Fruit	60%
Bunch Waste	40%
Shell	25% of the fruit

Waste estimates are:

Bunch	2.0 tons/acre
Fruit	1.2 tons/acre
Bunch waste	0.8 tons/acre
<u>Shell</u>	<u>0.3 tons/acre</u>

Bunch and shell wastes - 1.1 tons/acre

19,202	<u>Acres</u>	<u>1.1 tons wastes</u>	=	21,122	<u>tons-wastes</u>
	yr.	Acre			yr.

Kusi-Kade, where the Oil Palm Research Center is located, has 500 acres under cultivation for experimental purposes. The yield is 6 tons/acre per year.

Waste estimates:

500	<u>acres</u>	<u>6 tons bunches</u>	=	3,000	tons bunches/yr.
	yr.	Acre			

3,000	<u>tons bunches</u>	40%	=	1,200	<u>tons bunch waste</u>
	yr.				yr.

3,000	<u>tons bunches</u>	60%	=	1,800	<u>tons fruit</u>
	yr.				yr.

1,800	<u>tons fruit</u>	25%	=	450	<u>tons shells</u>
	yr.				yr.

Total oil palm wastes at Kusi-Kade:

Bunch waste	1,200 tons/yr.
Shell waste	<u>450 tons/yr.</u>
Total waste	1,650 tons/yr.

Total known oil palm wastes: 22,772 tons/yr.

One palm oil processing plant is located at Prestea. The plant processes 9 tons of bunches per hour. The operations schedule is 8 hours/day, 5 days/week. Estimated processing volume at the plant is 18,000 tons/yr., with bunch and shell wastes estimated at 9,900 tons/yr.

It was reported that a project was underway to plant 100,000 acres of oil palms in the next ten years under the joint efforts of a Ghana FAO/UN program.

Coconut shells and palm oil shells are two excellent feed materials for pyrolytic conversion. The dimensions are such that no pretreatment (chipping or hogging) of the feedstock is necessary. The materials have a high density, compared to hogged wood waste, which precludes the problems of bridging or "rat-holing" in the reactor. Both coconut and palm oil shell char make excellent activated carbon feedstock. At current market prices, the premium grade activated carbon produced from pyrolyzed coconut and palm oil shells would sell for about \$400/ton to \$500/ton. These two materials, then, deserve special attention.

2.0 PROJECT ACTIVITY

The project had five main phases of activities. A field survey of the potential sources of organic wastes for energy conversion for this project was conducted in Ghana and published under the title of "Pyrolytic Conversion of Agricultural and Forestry Wastes in Ghana--A Feasibility Study", in July 1976 authored by Chiang, Tatom, de Graft-Johnson and Powell.

The second phase consisted of selecting the demonstration site and the waste material that was both available and suitable for the project. The Ghanaian institutions which would become members of the joint venture were contacted and the groundwork of the project was completed in December 1977.

In January, 1978 the third phase began. The prototype pyrolysis unit was constructed and tested at the TCC workshop. Modifications were incorporated into the system and testing continued until May 1979, when the final design of the prototype was completed. The prototype unit produced acceptable quantities of good quality pyrolytic oil, gas and char.

In the fourth phase the construction of the system was completed. The four convertor, two dryer system was then transferred from TCC to the final site at Fumasua, where they were assembled. This phase was supervised by Mr. Kevin Davis of TCC and Mr. Frank Malvar of GIT during the period extending from June 1979 to July 1980.

The fifth phase was completed in July and August of 1980 by Malvar and Kovac. The integrated pyrolysis system was debugged and leak tested. Performance testing of the combined system was completed. Local personnel were trained in the operation of the pyrolysis system. An economic study and evaluation of the system was completed. A detailed operations and maintenance manual was included in the final report.

2.1 Field Survey

The Agency for International Development (AID) in 1976 contracted with the International Programs Office (IPO) of the Engineering Experiment Station (IENS) of Georgia Institute of Technology to determine the feasibility of pyrolytic conversion of agricultural and forestry wastes in Ghana. A team from Georgia Tech travelled to Ghana with funds provided by USAID (AID/ta-C-1290).

The feasibility study^{1/} designated as Project A-1823 was completed in July 1976. The objectives of the study were:

- (1) To determine the kind, volume, and location, of agricultural and forestry wastes.
- (2) to investigate potential markets for the products.
- (3) to make a preliminary design of a system that could be manufactured in Ghana.
- (4) estimate projected costs and profits.

This study concluded that:

1. Pyrolytic conversion is appropriate to Ghana.
2. Sufficient agricultural and forestry wastes are available for pyrolytic conversion on a large scale.
3. There is sufficient demand for the products of pyrolysis, namely charcoal, oil, and gas.
4. An EDL preliminary design of a continuous/batch pyrolytic conversion system appears to be economically feasible when operated on a two- or three-shift basis.
5. This design can be manufactured in-country using, for the most part, locally available components, and can be operated with local labor.

Based on the results of this study this project for the "Pyrolysis Demonstration Project in the Republic of Ghana" was initiated.

2.2 Project Definition and Site Selection

In November 1977, IPO began preliminary design work on a small-scale, labor intensive pyrolysis system. AID contracted with IPO to demonstrate the feasibility of the pyrolysis process in Ghana in December 1977. In collaboration

with the Technology Consultancy Centre (TCC) of the University of Science and Technology (UST) and the Building and Roads Research Institute (BRRI) in Kumasi, Ghana, IPO would (as listed in the first report on the demonstration project A-2076)^{5/} provide the following services:

- (1) Design a 6 ton per day pyrolytic convertor system and prepare working drawings for construction of this system at the TCC workshop in Kumasi, Ghana.

- (2) Provide technical assistance to TCC, which will undertake the manufacture of the unit.
- (3) Start-up and test the pyrolytic convertor system and make field modifications in cooperation with TCC and BRRRI until the final design has been adopted.
- (4) Assist in the preparation of an operating and maintenance manual.
- (5) Assist in the selection and training of local personnel to operate the pyrolytic convertor.
- (6) Evaluate the pyrolytic system.

The pyrolysis demonstration project was a joint venture between AID and the government of Ghana. AID, through Georgia Tech, supplied the technical assistance and some necessary equipment and materials not available in Ghana. The Bank of Ghana supplied BRRRI with the funds to build, operate and maintain the pyrolysis system. BRRRI constructed the building housing the pyrolytic convertors, while TCC was subcontracted to manufacture and assemble the reactor vessels and other modules. BRRRI then assembled the system, and provided the labor force for the testing.

In December 1977, GIT personnel (John Tatom and Phillip Potts) traveled to Ghana to define the scope of activities regarding BRRRI and TCC, and to investigate the availability of materials and supplies necessary for the construction of the pyrolysis system. They also spoke to representatives of the Bank of Ghana to coordinate funding to be used by TCC and BRRRI during the planned pyrolysis experiments.

2.3 Project Design and Fabrication

During January through March, 1978 GIT personnel (John Tatom and Kermit Moh) supervised and took part in constructing, testing, and modifying the first of four modules that would make up the 6 ton per day pyrolysis system. They also supervised the design and early part of construction of the building which was to house the convertors. The first of four convertors was built and tested at TCC. Typical product yields from those tests were: char - 15%, pyrolytic oil - 4%, and combustible gases - 81%, by difference -- all on a dry basis. The oil yields were lower than expected so a fair amount of attention during the testing phases was focused on increasing oil yields. The burner designed for the dryer was tested, and was judged to perform well. The pyrolytic gases were capable of ignition, and once lit, the burner was self-sustaining on pyrolytic gases.

During this phase, a number of problems were experienced by the GIT team in obtaining the necessary supplies and materials to build the first reactor. In early March 1978 the project was estimated to be 3 to 4 weeks behind schedule. Three pyrolytic convertors and the two dryers had yet to be fabricated. The building to house the convertors remained to be completed, and electric power had not been run to the site. On March 22, 1978, a meeting was held in Accra between GIT and AID. AID accepted a revision in the program whereby GIT personnel would leave Ghana until all fabrication and construction on the project was completed. AID would notify GIT when all preparations were finished. The GIT team would then assist in the assembly and installation of the system, continue with operation and testing, and finish the remaining scope of work.

When the first convertor was tested, the main problems were uncovered. The first involved the agitator-stirrer. "It was found that in Ghana the sawdust which was used as feed material in the first module was much finer and denser than that used to test the prototype in the U.S. As a result, it was extremely difficult to rotate the agitator. This problem was mitigated by removing the top three of the six blades on the agitator and adding wood shavings to the sawdust to reduce its density. The performance of the reactor was not affected by this change."^{5/} Later on, in 1979 another blade was removed. Modifications in the reactors were made and operation procedures implemented in 1980 when this problem was completely solved.

"The second problem was concerned with the unevenness of the air distribution in the reactor. When the convertor was running and air was introduced into it, intense heating of the reactor shell occurred in an isolated area. This area was directly beneath the filter which filters the gases going into the condenser. The sawdust was less dense beneath this filter; as a result, the air coming into the convertor tended to concentrate at this one spot, causing intense burning. This problem was alleviated by dividing the air intake in quadrants with a control on each quadrant, by reducing the size of the pebbles in the pebble bed, and by water jacketing the hottest zone of the reactor."^{5/}

During the first series of tests on the first convertor in Ghana the following was reported, "There was also a hot spot directly under the off gas pipe. This has consistently been an area of trouble due to the fact that the feed is not as dense in this area."^{6/} The first attempt to solve the problem used sand in an

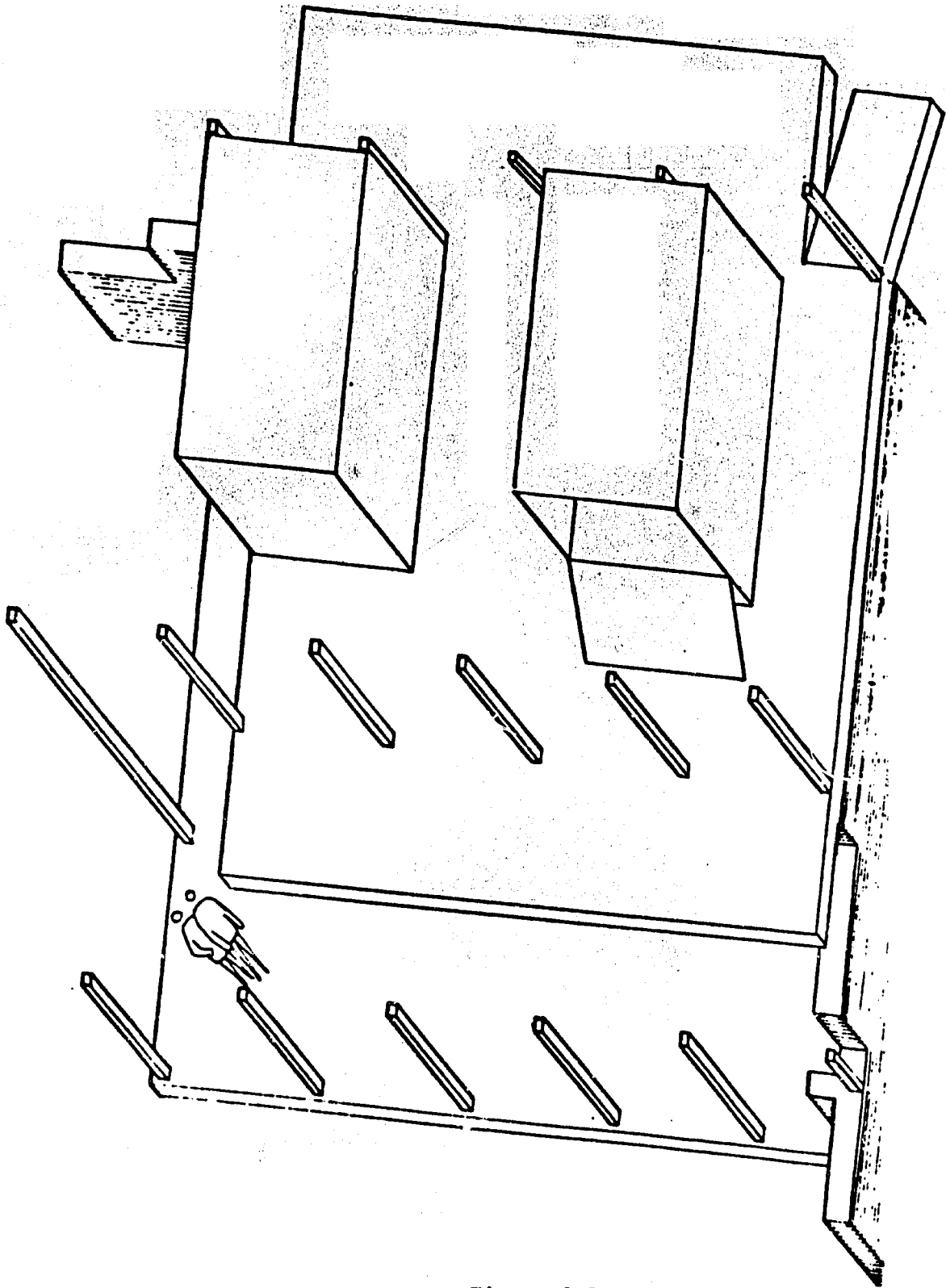

Figure 2.1
Artist's Preliminary Conception

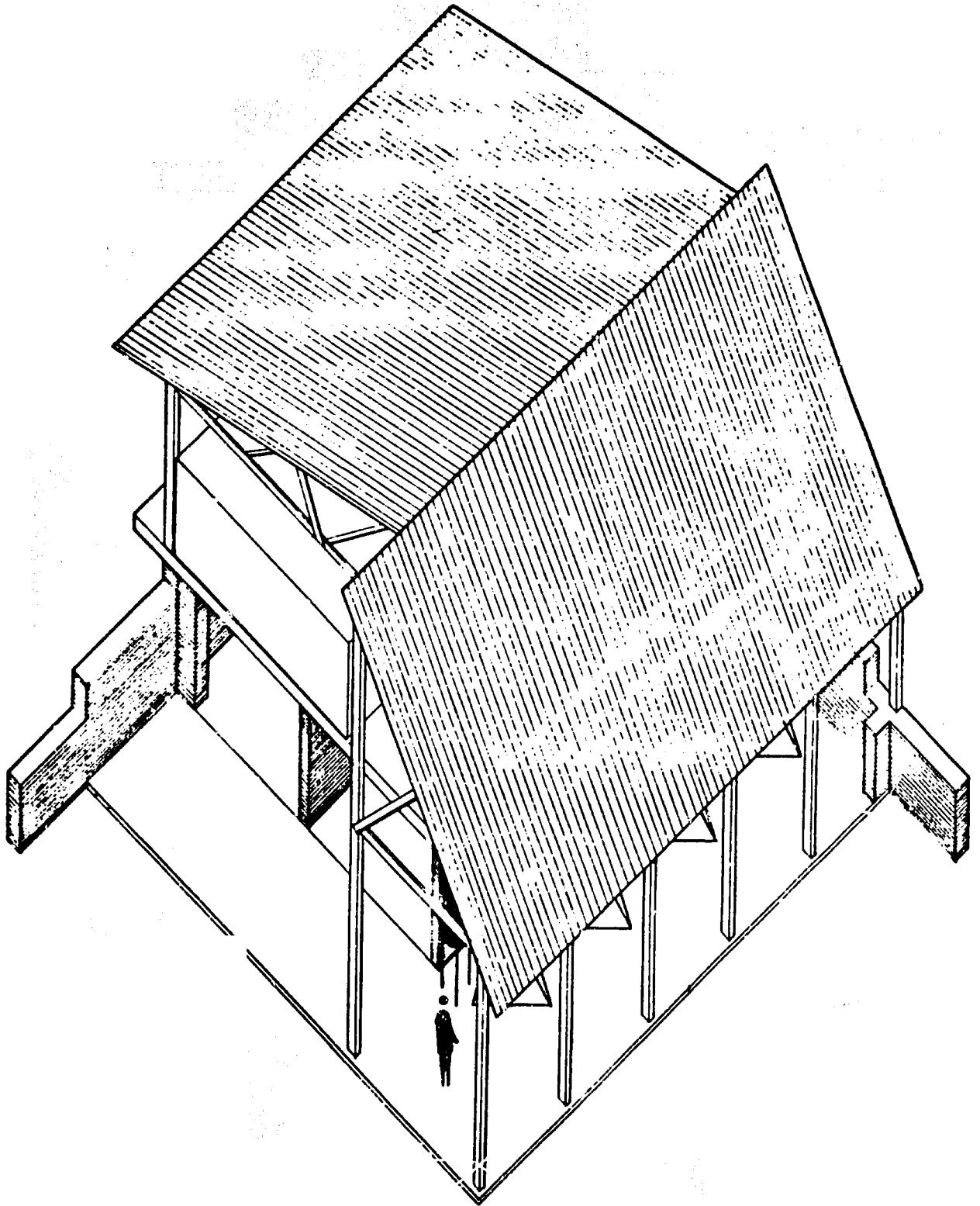

Figure 2.2
Artist's Preliminary Conception



Front View of Shed

-23-A



Front View of the Four Reactors and Condensers

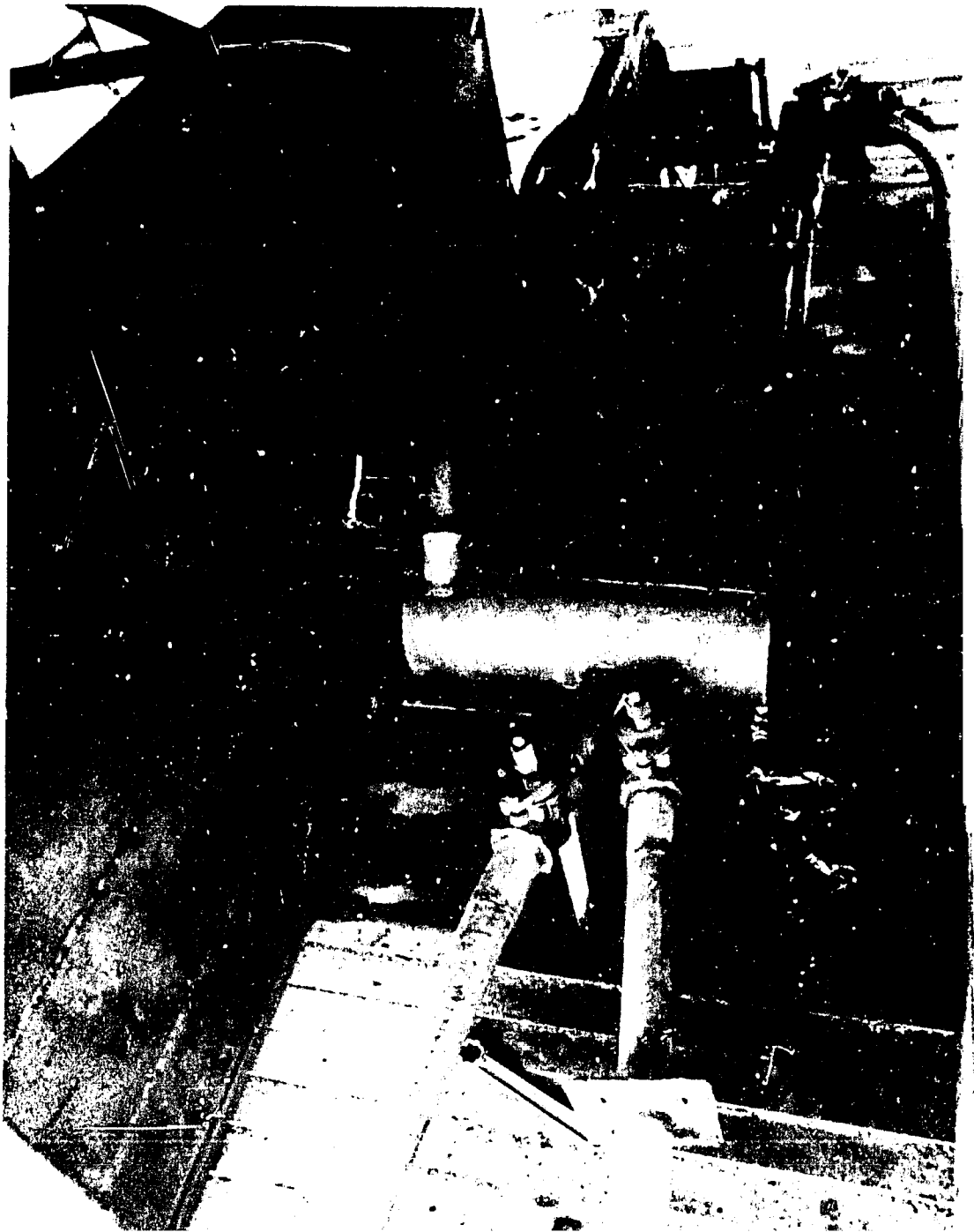

Top View of Gas Manifold



View of Manifold, Scavanger Fans and Top of the Reactors (background), while System is in operation.

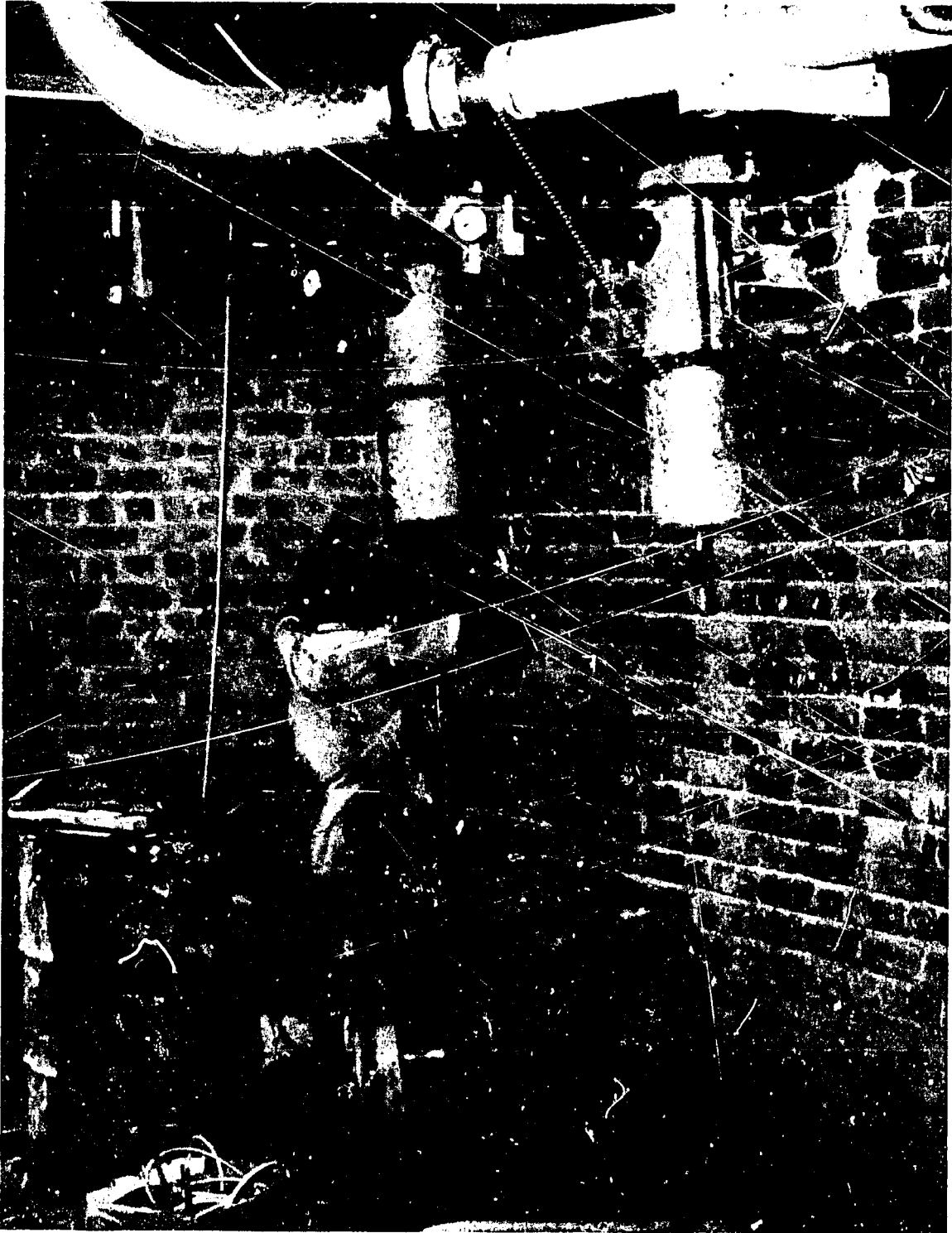

Laborer collecting Oil of Demisters

effort to redistribute the air flow. "The pebble bed will also be modified so as to reduce the hot spot which occurred under the off gas port. (Sand will be used to increase the resistance of the air bubbling through the bed. This will be done only in some places.)"^{6/} In some areas the sand was packed between the pebbles, in others areas sand replaced the pebbles. A test was then conducted. "The convertor was then reassembled, and a hot test was performed. It was found that the unit still acts as a gasifier and that cavities were formed. No char bed, to speak of, was formed; but some oil and combustible gas were produced."^{6/} Several more attempts were made using more sand until on March 8, 1978: "Today, a water jacket was installed around the hot spot of the convertor. This will temporarily keep the metal walls cool. A more permanent solution will control the flow of air into the convertor from four different quadrants."^{6/}

Some clarification is necessary. A hot spot is commonly known as an area, from about 4' in diameter to about 12" in diameter, caused by the temperature of the material in the reactor increasing to a point where the metal of the reactor shell turns red hot. Hot spots are dealt with immediately upon discovery. It is possible, though very highly unlikely, to have a hot spot spread around the circular perimeter of the reactor. The water jacket mentioned above was a piece of sheet metal welded to the outside of the convertor shell so as to form an annular reservoir for cooling water. The annular volume had a radius about 3" greater than the reactor vessel, and was about 12' high, overlapping the hottest reaction zone of the convertor.

The solution of providing air from four different quadrants was twofold. A ring of pipe (airline) was installed circling the reactor. The ring was installed so as to form 4 isolated quadrants. Each quadrant was equipped with a control valve, and each was supplied with air by a separate line (4 in all) originating at the main air control valve. Tests showed that this solution caused some improvement. But, the air, instead of flowing vertically up into the bed of feed material traveled through the pebble bed to the area beneath the off gas pipe and then entered the bed (short circuit through the pebble bed). This problem was not solved until 1979, by isolating the pebble bed into four quadrants using metal plates, thereby preventing the horizontal flow of air.

The problem of hot spots was caused by two reasons, the distribution of air inside the reactor (not to the reactor), and the amount of air being fed to the reactor. In the vertical bed reactors in use at Georgia Tech, air is introduced,

somewhat uniformly, into the bed of material and rises vertically. The air mixes well with the feed material until it passes out of the bed into an empty chamber above the bed, the freeboard section. The gases then flow into the off gas system. In the small-scale, prototype, Ghana convertor the air does not flow vertically through the entire bed.

The upper 2/3 of height of the feed material is used as a gas seal, of a sort. The air enters the bed vertically and is immediately drawn, channeled, and concentrated toward the off gas filter. Solid particles nearer the off gas filter would be subjected to an environment increasingly richer in oxygen (while recognizing the dilution effect of the combustion products). This oxygen rich environment combined with the lowering in feed material bulk density in the region below the offgas filter (caused by nonuniform flow of solid particles) causes the high incidence of hot spots in the area below the off gas filter. (Note: Hot spots are not confined to the area below the off gas filter. They may occur anywhere throughout the hot bed. But, in the Ghana convertors, a hot spot has never occurred directly above the offgas filter nor at any elevation higher than the bottom of the off gas pipe).

Another advantage of this modification is that the amount of air being fed to the convertor, is more easily controllable. In the pyrolysis process, one of the most closely watched parameters, when attempting to produce pyrolysis products of predetermined specifications or yields is the air to feed ratio. Vertical bed convertors of the Georgia Tech design can theoretically operate on an air to feed ratio of 0.25 lb. air/lb. feed material, dry basis. Pyrolysis tests were generally conducted with an air to feed ratio (A/F) of 0.25 lb. air/lb. feed to 0.50 lb. air/lb feed. An A/F greater than 0.50 lb. air/lb. feed tends toward gasification and combustion. If high A/F's are necessary to sustain the reaction the oxygen may not undergo ample mixing with the bed material. A large percentage of the incoming oxygen may channel through the bed and exit unreacted through the offgas system. The nitrogen associated with the "excess", unreacted oxygen contributes to the dilution of the combustible gas stream. An analysis exhibited in Appendix C shows that some earlier pyrolysis tests may have been conducted with an A/F of 0.80 lb. air/lb. feed to 2.0 lb. air/lb. feed, which is excessive. The hot spot problem and underlying operational problems have been treated and solved by series of actions. No air is admitted to the quadrant below the offgas filter. A minimal amount of air is added through the

central air valve. The remaining 3 quadrant valves are constantly adjusted to reach and maintain a bed temperature in the range of 800° - 1200°F throughout the cross-section of the convertor at the plane of the thermocouples. And finally, the main air valve is continually throttled back after startup until the A/F ratio falls in the desired range. This routine requires constant operator attention to prevent localized overheating, but produces the desired results and solves the problem.

The last major problem was stated: "Problem three was caused by the temperature in the condenser being too low. As a result, water vapor was condensing with the oil instead of staying in a vapor state. This will be resolved by raising the temperature of the gases entering the condenser, thus raising the temperature of those leaving it. The condenser also will be insulated if necessary." Several modifications were tested and a new condenser design was later incorporated into the system in July 1978.

As shown by the previous discussions, there existed, in March 1978, several areas concerning the prototype where improvement could be made. At the request of USAID of team from GIT consisting of John Tatom, John Goodrum and Kermit Moh, was sent to Kumasi, Ghana in July 1978 to continue development on the prototype. The major effort of this team was directed towards the oil collection system. All parties involved were concerned due to previous low oil yields. After two weeks the GIT team returned to the U.S. After designing and testing a new model of condenser and adding a demister to the offgas system. The results from this phase of testing were described as follows: "However, oil yields were substantially increased -- from 0.4% to 5.4%, assuming the same processing rate of feed material."^{1/} Three conclusions evolve from this series of tests, the first two noted by visual observation. First, the final design of the condenser and demister assembly performed very well, much better than all previously tested designs. Second, the oil collected during these tests was indeed pyrolytic oil, not "brown water" or a mixture of "brown water" and pyrolytic oil which is produced when the pyrolysis system is operated below optimum conditions. Third, the exact amount of the oil yield or the percentage increase of the oil yield is unknown since the feed rate was not measured. It is possible that the feed rate had been increased over that of previous testing. If, as discussed earlier, the convertor is operating with a high A/F and tending toward gasification, and increase in the feed rate would shift convertor parameters into a range that

would favor increased oil production. In any event, a considerable increase in the oil yield was achieved. The GIT team returned to the U.S. after about 2 weeks in Ghana.

Testing of the prototype continued from July 1978 through December 1978 under the direction of Ken Yeboah of BRRI. The two aims during this period were: (1) assembly of one complete pyrolysis system including reactor, offgas system, burner, draft fan, and dryer, and (2) fabrication of the major metal parts of the remaining convertors and dryer. During September - October 1978 Frank Malvar joined the project in Ghana, and continued development and debugging of the single, complete, prototype system. During this period the modifications to the system and operation procedures paid-off. Oil yields increased from an average of 4% to 8%, char yields from 15% to 20% and the throughput from 33% to 67% of design capacity. During the last half of 1978 work also continued on the building to house the four reactors. A 500 KVA transformer was delivered to the site at Fumasua in December 1978 but was not installed.

Construction, fabrication and testing continued at TCC during the first half of 1979. In May 1979 Frank Malvar travelled to Ghana to further develop and test the system. More modifications were incorporated into the system and changes made in the operational procedures. The oil yields increased to 11.26% (about 80% of the designed estimate) char yields were up to 25% (100% of the designed estimate) and the throughput to 100%. The period of prototype development was ended and the final, combined, four-convertor system design was completed.

2.4 Construction of the Four-Convertor Integrated Pyrolysis System

During the period May to September 1979, installation of the components of the combined system was started and the building to house the four convertors was completed. Efforts were continued to have the power connected to the plant site and the electrical wiring completed. These tasks were finally accomplished by September 14, 1979. In August and September 1979 Frank Malvar was in Kumasi to supervise and assist in the above activities. Clint Stone joined Frank Malvar in Kumasi from September 13 to September 28, 1979. At the end of September 1979 a substantial amount of work remained before the complete system could be tested. A meeting was held in Accra on September 28, 1979 to draw up a list of tasks and a time schedule for the remaining work. GIT was to be notified at a specified

point of completion. Frank Malvar would then return to Ghana, tentatively for the period November 5 to Dec. 21, 1979 to test the system and finish the project. The termination date of the contract was December 31, 1979. (A chronological history of the pyrolysis demonstration project is given in Appendix E.)

2.5 Performance Testing and Demonstration

In July 1980 final assembly of the integrated pyrolysis system was completed under the supervision of Frank Malvar. The offgas piping for the four convertors to the scavenger fans to the dryers and the manifold was installed. The second burner was assembled and a series of tests were conducted.

In August 1980 Kovac joined Malvar and the system was debugged, leak tested and sealed. The operation of various combinations of two or three convertors was tested and some additional modifications were made to the system. The final phase of testing was then undertaken, testing the performance of the combined, four convertor pyrolysis system. Once the results were satisfactory to all the parties involved, the GIT team left Ghana and the project was terminated.

3.0 PYROLYTIC SYSTEM DESIGN AND PROCESS DESCRIPTION

3.1 Pyrolytic System Components

The system has the following major components: four steel reactor vessels, each reactor having an input airflow and diffuser arrangement, a stirrer/agitator rod, a char removal system, a gas filter, a condenser and demister for oil extraction; a manifold that mixes all of the gas produced by the four reactors and two burners connected to this manifold that burn the gas produced to heat the two dryers. The yield of pyrolytic products is improved if the feed has a moisture content less than ten percent. Under conditions where all feed must be pre-dried, the pyrolytic gas can be piped directly to a burner producing hot air for drying.

a) Reactor Vessel - The main body of the converter is a conical section rolled from $\frac{1}{4}$ " to $\frac{3}{16}$ " mild steel. The small conical angle of approximately 5° helps to ensure formation of a compact bed of material and some concentration of hot gases as they flow up through the reaction zones. There are two cylindrical shells around the reactor body. The lower shell surrounds the high temperature zone and is filled with water to maintain the temperature of the reactor vessel well below the yield point of steel and to provide thermal insulation for the external surface. The upper shell is filled with sawdust, both to insulate the external surface and to reduce heat losses.

Each of the four reactor vessels is supported by a tripod of angle iron. This elevates the bottom to accommodate the char barrel. A spring loaded pressure relief valve is located at the top of the reactor and another one below the pebble bed. The valves should be adjusted to open at overpressures of about 25 oz. per square inch.

b) Input Air System - The air required to sustain the pyrolysis reaction is supplied by a belt-driven, high speed blower. The blower is capable of producing several times the nominally required airflow at the maximum expected pressure drop across the reactor bed. Air from the blower is fed through a one-inch diameter pipe to a manifold at the bottom of the reactor vessel. The primary airflow control is a valve in the one-inch line. This line also contains a calibrated orifice and a companion pressure gauge. The airflow in CFM can be determined from the pressure reading with the aid of a calibration curve.

The manifold feeds air to four injection pipes, one in each quadrant of the reactor and one to the middle injection pipe. Individual valves control the flow to each quadrant and permit balancing of the airflow and adjustment to eliminate hot or cool spots that may develop during operation. A fifth valve controls the flow of air into the middle of the reactor. These five valves gives a tridimensional control of the burning area.

The curved air injection pipes lie in the horizontal plane and have a series of holes in their upper surface. The pipes are surrounded by pebbles which provide insulation from the high temperatures in the air injection zone and serve to further diffuse the air entering the reaction bed.

c) Raw Material Feed - At least a one or two week supply of sawdust or wood shavings should be maintained at the pyrolytic convertor site. The desired inventory is a function of availability of transportation, drying capacity (if pre-drying is required), peak throughput rate, and the raw material delivery cycle.

d) Stirrer/Agitator - Variations in moisture content, air channeling, etc., can result in uneven pyrolysis and, over time, voids can be created. If left undisturbed, the air in these pockets will further increase the reaction rate in the vicinity. Extreme temperature and excess gasification will result. A rod with two paddles attached is positioned in the center of the convertor. The rod extends above the reactor with handles for manual operation. One paddle is located right under the filter casing, where most of the cavities and voids occur due to low density of the feed in this area and high air flow. This blade provides several functions:

1. It compacts the feed.
2. Eliminates cavities
3. Cleans the filter of the feed crust and condensed oil that tends to build up on the underside when the blade sweeps under it.

The second paddle is located at a depth which indicates that more feed is needed. With the paddle positioned at this point, an experienced operator can tell by the change in the stirrer's resistance whether or not more feed is needed. The stirrer should be put through 20 complete revolutions about every 10 or 15 minutes.

e) Char Removal - The pebble bed has a large center hole through which char can pass to a grate located directly beneath the pebble bed. The grate is made from two sections of steel plate with matching holes and an agitator. The holes can be offset by moving a pivoted lever which slides the bottom plate back and forth. The grate is normally closed in operation. When sufficient char has accumulated, the lever (mounted at the side of the reactor) is rocked back and forth to allow the passage of char.

A flanged, 55-gallon drum is securely fastened to the bottom of the reactor with bolts. The char falls into the barrel which serves as a receptacle and a convenient storage container. Barrels are easily changed by loosening the bolts, moving the full barrel to the side and then attaching an empty drum with the retaining bolts.

f) Gas Filter - The pyrolytic gas leaves the reactor at moderate velocity and entrains carbonized particles, dust, etc. If not removed, this solid material would rapidly clog the oil removal system. Conventional engineering practice would employ cyclone or precipitation filters to extract particulates from the gas. These methods, while effective, are expensive and the equipment requires extensive maintenance. This pyrolytic converter is designed with a simple mechanical filter with unburned sawdust or wood shavings as an integral component. A 3-inch diameter pipe, connected to the wall of the reactor vessel, projects into the reactor bed above the pyrolysis zone. Gas flows through heated, but unburned, sawdust to reach the filter pipe and most particulates are trapped by the sawdust. The pipe has a series of holes in the bottom half of the cylinder allowing gas to enter. A smaller pipe, usually 2 1/2 inches in diameter, is centered inside the larger pipe. The central pipe has holes over the entire cylinder and is wrapped with a fine mesh screen. Gas leaves the reactor through the inner pipe and particles which enter the outer pipe have a high probability of being trapped on the screen between the pipes. The screened inner pipe can be removed for periodic cleaning.

g) Oil Removal - The filtered gas leaves the reactor at temperatures in the 300 - 400 °F range and contains volatilized tars, methanols, mixed phenols, cresols, fatty acids, acetic acid and water. Condensation at 200 °F will remove much of the high molecular weight organics and acids while leaving a high fraction of the water as vapor in the gas stream.

This design uses a simple jet condenser. Gas from the reactor enters the vertically mounted condenser and flows down through a central pipe with 120 holes drilled in its surface. The gas exits laterally through these holes with high velocity and impinges on the inner surface of a steel tube which contains the pipe. The cooler surface combined with the change in gas velocity at the wall produce condensation. Droplets of pyroligneous liquor (oil) collect at the bottom of the condenser, and the gas exits through a pipe connection at the top of the outer tube.

The condenser is surrounded by a water jacket which helps maintain the condenser surface temperature low enough so as to extract most of the oil contained in the gas.

Variations in condenser temperatures and the efficiency of this simple condenser design can allow some oil droplets to be entrained in the gas leaving the condenser. A demister has been added to further clean the gas and reduce its water content. Gas leaving the condenser is passed through a large pipe containing metal shavings in its upper half. As gas passes through the lathe shavings, entrained oil and water are condensed and drained, through a screen supporting the shavings to a collection chamber below.

The demister is followed by a scavenger fan to aid the flow of gas through the condenser, demister and out to the burner.

In applications where gas with a high energy content is desired, it would be advantageous to eliminate the demister and utilize the gas/oil mixture. However, long pipe runs could result in oil condensation before the gas reaches the combustion chamber. This would create a maintenance problem.

h) Manifold - When the gas leaves the demister, it is propelled by the scavenger fans into a manifold that mixes all of the gas produced by the four reactors and then separates it into the two burners. This is done so that when one reactor is not working, either because it is being reloaded or repaired, the total amount of gas going into any of the burners is half of what is being produced.

i) Burners - These specially designed burners are to operate with the gas produced by the system and are used in conjunction with the two dryers that the system has to dry the feed to the needed moisture content.

3.2 Process Description

This system operates as a batch-continuous, self-sustaining, partial-oxidation pyrolysis process. Air (oxygen) is introduced into the converter to produce an exothermic chemical reaction which generates the heat required for pyrolysis. The quantity of air is kept small so that complete combustion cannot occur.

The process is initiated by starting a fire inside of the reactor and introducing a batch of feed. Air is fed to the system and the reaction spreads until standard operating conditions are reached.

The reactor vessel is a vertical cone in which the feed material passes through three temperature zones during the process. Dry feed is fed at intervals through the top of the reactor and falls to the top of the reaction bed. In this upper zone the feedstock is exposed to hot gas in the 200 - 400 °F range. The fresh feed is further dried and pre-heated in the presence of the hot gas.

The feed progresses downward by gravity as mass is reduced in the lower region by pyrolysis and by the removal of char. In the pyrolysis zone, temperatures range from 600 to 900 °F and the feed decomposes into charcoal and organic gases.

Next, the feed enters the air injection zone characterized by temperatures up to 800 or 1200 °F. Here further volatile matter is released and additional carbonization of the char takes place. This zone is the primary source of heat for the process. High temperature gases pass up through the bed to create the zones described above.

Char passes through the air injection zone to the accumulation chamber formed by the pebble bed and the grate. The process is complete at this point, and char is periodically removed to the storage drum attached to the reactor.

The hot gas containing water, hydrogen, methane, carbon dioxide and heavier organics is extracted from above the pyrolysis zone. The gas is separated into a condensible fraction (oil) and low Btu gas by a jet condenser.

4.0 PROJECT RESULTS

Project personnel (Dr. John Tatom and Mr. Kermit Moh) spent the months of January, February and March of 1978 in Ghana constructing, testing and modifying the first of four modules that made up the complete six-ton-per-day convertor. They also supervised the design and initial building of the shed which would house the convertors. This team together with Dr. John Goodrum returned in July 1978 and finished the condensing unit of the system.

In August 1978 Mr. Ken Yeboah of BRRRI initiated a series of tests designed to provide enough data as to give the guidelines in the required modifications or development of the system as well as to develop the best operating procedures. Mr. Yeboah was joined by Mr. Frank Malvar of Georgia Tech during September and October 1978, when new modifications in the system and in the operation procedures were incorporated resulting in an improvement of about a 100% in the results.

During the period of time between October 1978 and April 1979, Mr. Yeboah conducted tests as specified, modified the operation procedures and supervised the construction of the other three units in the TCC workshop.

In April and May 1979 Mr. Malvar returned to Kumasi, and new modifications were implemented based on the results of the testing. The results were vastly improved with the system producing good quantities of good oil, gas and char. At this point Dr. John Powell, Director of TCC, who had been following closely the project since the beginning, Mr. Yeboah and Mr. Malvar agreed that the system was performing as well as expected, and no new modifications were deemed necessary. So the go ahead was given for the completion of the other three reactors and the remaining parts of the system.

In August 1979 Mr. Malvar returned to Kumasi, and the transfer of the system from the TCC workshop to the final site in Fumasua was accomplished, as well as the necessary power connections and completion of the systems and the building. Mr. Stone of Georgia Tech arrived the last 13 days of this period to help in the final layout of the system.

In July and August 1980 Mr. Malvar returned to Ghana, and the first phase of the testing of the system was undertaken. During the last three weeks and in the second and final phase of the testing of the system, Mr. Ray Kovac of Georgia

Tech joined the team; and after the system was tune-up, debugged and the expected test results were met and surpassed the project was terminated.

4.1 Mechanical Considerations

The pyrolytic convertor system over the period of this project went through many modifications in the design and in the operating procedures. Once these modifications were tested and proven successful, they were incorporated in the other three reactors that comprise the system. The following indicate some of the design changes, modifications and mechanical problems encountered, and includes suggestions for minor improvements in the future designs.

Pebble bed - This was introduced early in the development of the system and with the modifications or further development done to it in the later part of the project, it accomplished its purpose very well and needs almost no maintenance. It has the draw backs of being difficult to build, therefore rather expensive, extremely heavy and troublesome to install.

Char grate - This item had the tendency to jam during the early part of the project. Later on, with the addition of an agitator and the inversion of the grate i.e. the movable plate was placed under the fixed one, this problem was solved. It was very reliable in the last year of testing.

Char barrel - It takes about 10 minutes to remove and install a new barrel. This is 10 minutes that the convertor has to be stopped, and is therefore not producing.

A continuous removal of the char, has been discussed and designed. It should be inexpensive, very easy to implement, and it will vastly improve the system.

Condenser unit - There were four or five condenser designs tested in the system during the early development stages. With the introduction of the jet condenser and the demister all the problems were solved. This system proved to be very reliable, extracted most of the oil and water entrained in the gas. It is very simple and inexpensive to build and maintain.

Stirrer/Agitator - A big problem with this part was the bending of the blades. The problem was successfully solved, by removing the lower blade and always positioning the agitator, during operations in a position where the blades will rest in the cooler side of the reactor. A chisel mark on the reactor coinciding with a mark on the agitator did the job.

Reactor vessel - The advantage of having a conical shaped reactor have not been proven. At the same time this introduces a lot of complexity in the fabrication and increases vastly the cost of the system. The water jackets added around the combustion zone, solved the problem of the "hot spots" in this area. It also gave a visual indication of the temperature and burning characteristic inside of the reactor, just by observing the boiling water in it. An improvement to the reactor maybe to add refractory bricks inside of it.

Filter - The problem with the clogging of the filter was solved by positioning a blade about $\frac{1}{2}$ to 1" under it. This also solved the problem of having a "hot spot" under the filter, due to lower density of the feed and too great air flow in this area. It is our belief that in future designs the filter should be positioned at the center of the reactor, rather than at one side. All of the problems mentioned above will then be solved.

Motors - All the motors in this system performed very well. If there is a fault in the system, it is that they are overdesigned. The windjammer could be substituted by a smaller less expensive motor/blower. The prototype unit was tested with a used vacuum cleaner as a blower that performed very well. The Chicago blowers that discharge the hot air into the dryers from the burners, could be substituted by blowers similar to the scavenger fans. The four scavenger fans could be replaced by one or two units rather than operating with four, or four smaller and less expensive fans could be used.

4.2 Process Operations

After many modifications and improvements in the operation of the system a final operational procedure was developed and is described in Appendix B (Operation and Maintenance Manual.)

The startup is a crucial part of the operation of the reactor. Once fire has been started inside of the reactor, the hot zone must be spread uniformly using the air valves that control the input air to each of the four quadrants. Once this has been accomplished and operation has started, steady state in the system should be attained by a low airflow (slow startup).

Once operating temperature has been reached then airflow should be increased to about 0.6 inches of water. The system once in steady state will

usually remain stable. If any individual temperature deviates from the norm, the airflow control valves should be used to control it.

4.3 Product Yields

The pyrolysis of tropical woods, in the form of sawdust and wood shavings, was extremely successful. As shown in the summary of the test were increasingly better, and all the designed estimates were met or surpassed. (See table 4.1)

Table 4.1

	Average test* runs until <u>Sept. 1978</u>	Average test* runs in <u>Oct. 1978</u>	Average test* runs in <u>May 1979</u>	Final test** <u>Aug. 27, 1980</u>	<u>Design Specs.</u>
Dry Feed throughput (Z)	33.33%	66.67%	100%	78.5%	100% (6 tons per 24hrs. of operation)
Char Yield (Z)	15%	20%	25%	25%	25%
Oil Yield (Z)	4%	6-7%	10.26%	17.337%	18%
Gas (to fire burner)	Inadequate	Inadequate	Adequate	Adequate	Adequate

* Tests were conducted in the prototype
 **The complete system (4 reactors)

5.0 ECONOMIC ANALYSIS

*Jargon.
Not a clear idea
clearly expressed
the whole section*

The economic value of this project will be measured in terms of observable prices, but the interpretation of that value must be made in the proper context. This section will be divided into two parts. The first part will deal with the total pecuniary costs and benefits of the project, measured by the monetary values of

- o the material, land, and labor inputs into the hardware installation
- o the products of pyrolysis or their closest substitutes,

Prevailing market prices will be used in all cases, whether controlled or not. Waiting times, inconveniences, and so forth will not be included to this benefit-cost calculation. The second part of this section will deal with the appropriate manner of interpreting the benefit-cost calculations.

These calculations are done to illustrate the benefit-cost relationships of the technology as it may be applied in the public sector in Ghana. The analysis will not evaluate the specific demonstration project, since there is no policy-related or decision-making reason for making such an evaluation. The project will be used as a basis for specification of an applicable technology and thus for costing out the technology. In addition, the interpretation will deal with the technology as generically applied in developing countries--Ghana in particular--in the private sector.

5.1 Pecuniary Costs and Benefits

The project is currently operating under far different conditions than were foreseen in the feasibility study. For the purposes of this study, certain assumptions must be made about the parameters of the project. Such assumptions are necessary in order to make costs and benefits occurring in different time periods comparable to each other, to decide which are true costs or benefits, and to decide which prices are appropriate to enter into the calculations. We will make the following assumptions:

- o The appropriate real discount rate for all monetary units is 12%.
- o Inflationary increases in price are ignored for all relevant goods and services. This is done because of the uncertainty in estimating the specific inflation rate relative to various goods

and services. It should be noted, however that the World Bank reports that the GDP inflator and the Wholesale Price Index have both been increasing over the period 1976-1978.

- o Applicable prices are subsidized prices, controlled or recommended by the government of Ghana. Where no controlled price exists, the free-market price is used.
- o The breakdown between labor and materials in construction is 25% versus 75% respectively. This ratio is used when only a total, aggregated cost is available and labor must be separated from materials.
- o Expenditures were made at specific points, in equal installments, evenly spaced over a time span, if only a total is available.
- o When an alternative configuration of a component can be used, the actual applicable price of the component used will be entered into the calculations, even when another configuration might have been more or less expensive, unless accurate costs for the alternative are available.
- o The expected life span of the installation is seven years, with the hardware depreciating to zero value at the end of its useful life.

Since the value analysis deals with the technology and not the specific installation or experiment, the following policies will be established:

- o Duplicate, redundant, or research-related costs will not be counted, except to the extent that they contributed to the practical operating or construction costs of the project.
- o Prior studies of feasibility will be excluded from the costs of the installation.
- o When land, materials, or labor are acquired, the applicable market price will be assigned, regardless of the price actually paid.

The costs of the project may be divided into the following areas:

I. Capital Costs

A. Components

1. Hardware and Materials
2. Labor used in construction

- 3. Other costs
- B. Financing
 - 1. Interest rates
 - 2. Term
 - 3. Service

II. Operating and Maintenance (O&M) costs

- A. Components
 - 1. Labor
 - a. administrative and supervision
 - b. production
 - 2. Materials
 - a. consumables (for operating)
 - b. capital improvements and repair of depreciation (for maintenance)
 - 3. Incidentals

III. Raw Materials

- A. Components
 - 1. Feedstocks
 - 2. Other inputs

IV. Taxes

The benefits of the project may be divided into the following areas:

- I. Sales Receipts or a stand-in when the outputs are not sold
- II. Scrap value of plant.
- III. Subsidies

Table 5.1 enumerates the component prices of the installation. The calculation of costs and benefits will be aided by the use of tables 5.1a through 5.1c and in tables 5.2a through 5.2d below. The costs and benefits will be listed within the table in values expressed in Cedis (¢). Each of the component costs is then entered into tables 5.3a and 5.3b to determine the present value of the net benefits or costs. The tables then contain discounting assumptions to reflect the cost of capital employed for startup.

The reader should note that as stated elsewhere in this report, the device was overdesigned with respect to certain components. The second subsection of this section deals with the interpretation of the impact of system design on economic feasibility.

Table 5.1a

COMPONENT COSTS OF PYROLYTIC REACTOR
(IN CEDIS ¢)

Qty	Component	Materials		Labor	
		Control	Available	T.C.C.	Contract
5	1/8" Steel Plates	600	1,500	900	900
1/2	1/4" Steel Plates	75	250	*	*
1	1/16" Galvanized Sheet	75	300	*	*
2	1 1/2" Pipe	120	240	*	*
1/2	1/2" Steel rod	52	80	*	*
8'	1" Steel rod	60	90	*	*
108	1/2" Bolts and Nuts	86	216	*	*
2	2" x 2" angle irons	120	300	*	*
12"	2 1/2" rod	10	20	*	*
6	welding electrodes (bundles)	<u>252</u>	<u>720</u>	*	*
	Welding gas		298	*	*
1	Windjammer and pulleys	788		* *	* *
2	Bimetal thermometer	226		t *	t *
4	Sets of Brass vells and pyrometers	664		o *	o *
1	Pressure Gauge	82		t *	t *
1	Gasket set	55		a *	a *
1	Magnehelic Gauge	82		l *	l *
6	1" Valves		90	<u>700</u> *	<u>1,500</u> *
SUB-TOTAL		3,735	6,001	1,600	2,400

Additional Components for System of Four Reactors

8	3" Valves	3,300
5	Oil Drums	<u>1,000</u>
SUB-TOTAL		4,300

SYSTEM WITH 4 REACTORS:

4 x 3,735	14,940	4 x 1,600	6,400
	<u>4,300</u>		
TOTAL REACTOR COSTS	19,240		<u>6,400</u>

Table 5.1b

COMPONENT COSTS OF CONDENSER AND DEMISTER
(IN CEDIS ₤)

<u>Qty</u>	<u>Component</u>	<u>Materials</u>		<u>Labor</u>	
		<u>Control</u>	<u>Available</u>	<u>T.C.C.</u>	<u>Contract</u>
1	1/16" sheet metal	75	300	*	*
2	valves	30	70	*	*
1/2	set welding gas	150	150	*	*
1/2	bundle welding rods	10	30	*	*
SUB-TOTAL		265	550	75	250

Additional Components for Two Condensers

2	Scavanger Fans with pulleys	766			
SUB-TOTAL		766			

SYSTEM WITH FOUR CONDENSERS

4 x 265	1,060	4 x 75	300
2 x 766	<u>1,532</u>		
TOTAL CONDENSER COSTS	2,592		<u>300</u>

Table 5.1c

**COMPONENT COSTS OF FEED DRYING APPARATUS
(IN CEDIS ¢)**

<u>Qty</u>	<u>Component</u>	<u>Materials</u>		<u>Labor</u>	
		<u>Control</u>	<u>Available</u>	<u>T.C.C.</u>	<u>Contract</u>
(dryer)					
13	1/16" Sheet metal	975	3,900	*	*
1	2"x2" angle iron	60	150	* *	* *
10	lengths box iron	1,200	3,000	t *	t *
6	sheets 1/2" plywood	480	480	o *	o *
11	hinges	132	132	t *	t *
4	1/2" sheet metal	480	1,200	a *	a *
1	set welding gas	298	298	1 *	1 *
8	bundles electrodes	336	960	700 *	2,000 *
SUB-TOTAL		3,961	10,120	700	2,000
(burner)					
1	1/8" sheet metal	120	300	* *	*
2'	8" dia pipe	50	50	t *	t *
30"	2 1/2" dia pipe	100	200	o *	o *
1/2	1/16" sheet metal	40	150	t *	t *
1/2	bundle electrodes	21	60	200 *	500 *
SUB-TOTAL		331	760	200	500
(duct work)					
1	angle iron	60	150	*	*
1	1/16" sheet metal	80	200	50 *	120 *
SUB-TOTAL		140	350	50	120

Additional Components for System of Two Drying Units

Chicago Blower and pulleys	2,940
SUB-TOTAL	2,940

SYSTEM WITH TWO DRYERS

2 x 3,961	7,922	2 x 700	1,400
2 x 331	662	2 x 200	400
2 x 140	280	2 x 50	100
	<u>2,940</u>		
TOTAL DRYER COSTS	12,084		

Table 5.2a

**COST CALCULATIONS FOR PLANT CONSTRUCTION
(IN CEDIS ¢)**

<u>Qty</u>	<u>Component</u>	<u>Materials</u>	<u>Labor</u>
4	Reactors	19,240	6,400
4	Condensers	2,592	300
2	Dryers	12,084	1,900
1	Shed	32,250	10,750
1/4	Transformer	6,500	
3	Electricians		619
TOTAL		72,666	19,969

Table 5.2b

**COST CALCULATIONS FOR OPERATING AND MAINTENANCE
(IN CEDIS ¢)**

(salaries)

2 supervisors per shift for 12 months @ ¢350/mo. per shift	¢ 8,400
13 laborers per shift for 310 days/yr. @ ¢5/day per shift	<u>20,150</u>
LABOR TOTAL FOR ONE YEAR PER SHIFT	¢28,550

(electricity)

16 KW power requirement @ ¢15.60/KWH flat rate up to 50/KWH/mo + ¢.19/KWH thereafter for 310 days per year.

	<u>Single Shift</u>		<u>Double Shift</u>	
total consumption	39,680 KWH/yr		79,360 KWH/yr	
at base rate	600 KWH/yr	¢ 187	600 KWH/yr	¢ 187
at ¢.19/KWH	39,080 KWH/yr	<u>7,426</u>	78,760 KWH/yr	<u>14,960</u>
		¢7,613		¢15,147

(replacement parts)

Ken Yeboah estimates that parts will cost about ¢200 per month for a 12-hour work day. We used ¢200 per month for 1 shift/day and ¢400 per month for 2 shifts/day.

Table 5.2c

**COST CALCULATIONS FOR RAW MATERIALS
(IN CEDIS ¢)**

feedstock

transportation (6 Tons of feed)

truck	550
fuel	40
driver	<u>0</u>
	590

to sustain operations for three shifts, six tons of feed are required, or one truck-day, or 1/3 truck-day per shift. Thus, for work year, the cost of trucking will be 1/3 truck per shift for 310 days or ¢60,967. For a two shift/day operation this increases to ¢121,933.

Table 5.2d

BENEFIT CALCULATION FOR SYSTEM OUTPUTS

Assuming one shift/day:	<u>Oil</u>	<u>Char</u>
Input amount	4,000 lbs	4,000 lbs
minus 10% drying loss	- 400 lbs	- 400 lbs
	3,600 lbs	3,600 lbs
times yield ratio	x.18 lbs out/lb in	x.25 lbs out/lb in
	648 lbs/day	900 lbs/day
	times gals/lb: x 0.1 gals/lb	
	64.8 gals/day	
times length of operation	x 310 days/yr	x 310 days/yr
	20,088 gals/yr	279,000 lbs/yr
times price per unit	x \$3.15/gal	x \$0.4/lb*
		times value ratio of powder to briquettes: x 1/4
VALUE OF OUTPUTS FOR 1 SHIFT/DAY	\$63,278/yr	\$55,800/yr
VALUE OF OUTPUTS FOR 2 SHIFT/DAY	\$126,554/yr	\$111,600/yr

*Note: Charcoal briquettes have an estimated price of \$0.8/lb based on current market conditions. While it is believed that powdered char from the pyrolysis unit has a comparable worth, for purposes of this analysis a price equal to 1/4 that value was assumed.

Table 5.3a

**CALCULATION OF BENEFIT/COST AND INTERNAL RATE OF RETURN:
(IN CEDIS ¢)
(FOR 1 SHIFT/DAY OPERATION)**

<u>Cost Component</u>	<u>Start-up</u>	<u>Year 1</u>	<u>Year 2</u>	<u>Year 3</u>	<u>Year 4</u>	<u>Year 5</u>	<u>Year 6</u>	<u>Year 7</u>
Investment								
Land	10,000							
Materials	72,666							
Labor	19,969							
Operating and Maintenance								
Materials								
1. Consumables								
a. Fuel		*	*	*	*	*	*	*
b. Electricity		7,613	7,613	7,613	7,613	7,513	7,613	7,613
2. Replacements								
a. Parts & Supplies		2,400	2,400	2,400	2,400	2,400	2,400	2,400
Labor		28,550	28,550	28,550	28,550	28,550	28,550	28,550
Incidentals								
1. Transport to Markets		0	0	0	0	0	0	0
Raw Materials								
Feedstock		<u>60,967</u>	<u>60,967</u>	<u>60,967</u>	<u>60,967</u>	<u>60,967</u>	<u>60,967</u>	<u>60,967</u>
TOTAL COSTS	102,635	99,530	99,530	99,530	99,530	99,530	99,530	99,530
Benefit Component								
Value of Outputs								
1. Oil		63,278	63,278	63,278	63,278	63,278	63,278	63,278
2. Char		55,800	55,800	55,800	55,800	55,800	55,800	55,800
3. Gas		*	*	*	*	*	*	*
Scrap Value of Plant								0
TOTAL BENEFITS	n/a	119,078	119,078	119,078	119,078	119,078	119,078	119,078
NET PRESENT VALUE (NPV)								
Discount Factors (12%)	(1.0)	(0.8929)	(0.7972)	(0.7118)	(0.6355)	(0.5674)	(0.5066)	(0.4524)

NPV OF TOTAL CASH FLOW (Benefit - Cost) = (-) ¢13,420

$$\text{BENEFIT/COST RATIO} = \frac{\text{NPV Benefits}}{\text{NPV Costs}} = \frac{543,449}{556,868} = .976$$

$$\text{INTERNAL RATE OF RETURN: } 19,548 \text{ (PVF 7yrs, r\%)} - 102,635 = 0$$

$$\text{PVF 7yrs, r\%} = 5.25$$

$$r = 7.76\%$$

*Fuel gas in = fuel gas out

Table 5.3b

**CALCULATION OF BENEFIT/COST AND INTERNAL RATE OF RETURN
(IN CEDIS €)
(FOR 2 SHIFT/DAY OPERATION)**

<u>Cost Component</u>	<u>Start-up</u>	<u>Year 1</u>	<u>Year 2</u>	<u>Year 3</u>	<u>Year 4</u>	<u>Year 5</u>	<u>Year 6</u>	<u>Year 7</u>
Investment								
Land	10,000							
Materials	72,666							
Labor	19,969							
Operating and Maintenance								
Materials								
1. Consumables								
a. Fuel		*	*	*	*	*	*	*
b. Electricity		15,147	15,147	15,147	15,147	15,147	15,147	15,147
2. Replacements								
a. Parts & Supplies		4,800	4,800	4,800	4,800	4,800	4,800	4,800
Labor		57,100	57,100	57,100	57,100	57,100	57,100	57,100
Incidentals								
1. Transport to Markets		0	0	0	0	0	0	0
Raw Materials								
Feedstock		121,934	121,934	121,934	121,934	121,934	121,934	121,934
TOTAL COSTS	102,635	198,981	198,981	198,981	198,981	198,981	198,981	198,981
Benefit Component								
Value of Outputs								
1. Oil		126,556	126,556	126,556	126,556	126,556	126,556	126,556
2. Char		111,600	111,600	111,600	111,600	111,600	111,600	111,600
3. Gas		*	*	*	*	*	*	*
Scrap Value of Plant								0
TOTAL BENEFITS	n/a	238,156	238,156	238,156	238,156	238,156	238,156	238,156
NET PRESENT VALUE (NPV)								
Discount Factors (12%)	(1.0)	(0.8929)	(0.7972)	(0.7118)	(0.6355)	(0.5674)	(0.5066)	(0.4524)

NPV OF TOTAL CASH FLOW (Benefit - Cost) = (+) €75,789

$$\text{BENEFIT/COST RATIO} = \frac{\text{NPV Benefits}}{\text{NPV Costs}} = \frac{1,080,752}{1,010,745} = 1.069$$

$$\text{INTERNAL RATE OF RETURN: } 39,175 \text{ (PVP 7yrs, } r\%) - 102,635 = 0$$

$$\text{PVP 7yrs, } r\% = 2.620$$

$$r = 32.98\%$$

*Fuel gas in = fuel gas out

High 12-hour shift (see p. 40) 2 shifts
24-hr (continuous) - 16-hr

The economic feasibility of the technology under the conditions prevailing for the demonstration experiment is encouraging. The internal rate of return under the two scenarios indicates that over the lifetime of the project, a one shift/day operation is insufficient to recover set-up costs over a seven year period if a 12% cost of capital is used. However, a two shift/day operation is sufficient to make such a recovery with a 12% cost of capital, even though the set-up costs are in the range of \$100,000. If a 12% cost of capital is held as the minimum return on investment criteria, this suggests that some compromise between a 1 shift/day and 2 shift/day could provide the necessary cash flow to make the project completely feasible economically. The availability of locally produced energy materials made from locally available raw materials adds to that attractiveness.

It must be stressed that the sale of both oil and char is essential to the economic feasibility of this program. The absence of the sale of either product, using assumed values in Table 5.2d, would create lower benefits than costs prior to any discounting and make the venture economically unattractive.

5.2 Interpretation of Benefit-Cost Calculation

The Benefit-Cost evaluation of subsection 5.1 may be accurate only in a few limited instances. A valid analysis depends on the principal for which the analysis is done. For example, private enterprise makes decisions on one set of criteria while a government agency decides differently. Private enterprise uses such criteria as profits or return on investment. Government is obligated to look at all costs and benefits, even external costs such as pollution, market dislocations, redistribution of income, and economic self-sufficiency or independence, among others.

5.2.1 Controlled and Subsidized Prices

Total costs and benefits must include both those that are private or internalized and those that are social or external. When prices are controlled or subsidized, such as in the labor market or the oil market, the consumer of labor or oil perceives their value one way while the value to society is more nearly the sum of market price plus subsidies. If prices are controlled, the true value is nearly impossible to determine. Controlled prices also result in waiting time spent in queues; that waiting

addition of
time also has value. Our estimates are that the true total value of domestically produced oil in Ghana may be as much as twice the ₵3.15 controlled price. For the sake of calculations, we recommend using the value ₵5.00 per gallon. The value of labor is difficult to assess. Labor can reduce its productivity to match the wages. We recommend not changing the way it enters into the benefit-cost calculation. Because of the difficulty surrounding the evaluation of waiting time, we recommend that the control prices be used for construction materials and parts, even though the contractor may have to wait to acquire them.

5.2.2 Design Specification: Engineering and Economic Considerations

In addition, the plant was not designed with balance of payment considerations in mind. In a country where wood resources are relatively more plentiful than steel, more components could have been made from wood. Where manufactured goods are difficult and expensive to procure, smaller motors could have been substituted for a saving of about ₵3,000. A concomitant savings in electrical consumption would be realized. Because of the uncertainty of such calculations, we do not make any charges in our evaluation due to these design issues. The shed that shelters the units ought to be possible to build at a cost of no more than US\$7.00 per square foot. Thus, a 1300 square foot shed should cost ₵18,770 for materials and ₵6,260 for labor. That changes the totals in table 5.2a to ₵59,186 and ₵15,479 respectively.

5.2.3 Socio-Economic Considerations

The powdered char that is available from the pyrolytic converter is not readily used by the population of Ghana, since they are not accustomed to it. On the other hand, there exists a simple and inexpensive technology to make it useful. Depending on the introduction of the powdered char-burning stove into the culture, the output of the converter may become economically more attractive. There is very little reason that the powder could not be sold for nearly the same price as traditionally produced charcoal. We do not make any calculations on the assumption, but it is clear that such an evaluation would greatly increase the enumeration of benefits of the technology.

63

5.3 Benefit-Cost Evaluation for Private Industry

In the instance of this pyrolysis technology, private industry would make the following changes in the calculations:

- o The costs of the shed that appear in Table 5.2a would change as described in section 5.2.2
- o The cost of transportation of feedstock appearing in table 5.2c would be zero
- o The value of oil that appears in Table 5.2d would not change according to the discussion in section 5.2.1 since private industry only considers the price it would pay or the price it could demand for sale.
- o The value of land that appears in Table 5.3b would be zero, since the converter system would occupy land that is now used to warehouse waste products, and therefore has zero opportunity cost.

The tacit assumption is that the lumber industry is appropriate for investment in pyrolytic conversion. If another industry were chosen for analysis, then the benefit-cost relationships would be different.

The result based upon the life-cycle value analysis is shown in table 5.4. The net present value of the system would be \$660,426 for private enterprise in the lumber industry..

5.4 Benefit-Cost Evaluation for Government

A government would make the following changes in calculating the total costs and benefits of the system:

- o The costs of the shed that appear in Table 5.2a would change as described in section 5.2.2
- o The value of oil that appears in Table 5.2d would change to \$5.00 according to the discussion in section 5.2.1.

The result based upon the life-cycle value analysis is shown in table 5.5. The net present value of the system would be \$432,596 for a government entity.

Table 5.4

CALCULATION OF NET PRESENT VALUE
(FOR 2 SHIFT/DAY OPERATION)

<u>Cost Component</u>	<u>Start-up</u>	<u>Year 1</u>	<u>Year 2</u>	<u>Year 3</u>	<u>Year 4</u>	<u>Year 5</u>	<u>Year 6</u>	<u>Year 7</u>
<u>Investment</u>								
Land	0							
Materials	59,186							
Labor	15,479							
<u>Operating and Maintenance</u>								
<u>Materials</u>								
1. Consumables								
a. Fuel		*	*	*	*	*	*	*
b. Electricity		15,226	15,226	15,226	15,226	15,226	15,226	15,226
2. Replacements								
a. Parts & Supplies		4,800	4,800	4,800	4,800	4,800	4,800	4,800
Labor		57,100	57,100	57,100	57,100	57,100	57,100	57,100
Incidentals								
1. Transport to Markets		0	0	0	0	0	0	0
<u>Raw Materials</u>								
Feedstock		0	0	0	0	0	0	0
TOTAL COSTS	74,665	77,086	77,086	77,086	77,086	77,086	77,086	77,086
<u>Benefit Component</u>								
<u>Value of Outputs</u>								
1. Oil		126,556	126,556	126,556	126,556	126,556	126,556	126,556
2. Char		111,600	111,600	111,600	111,600	111,600	111,600	111,600
3. Gas		*	*	*	*	*	*	*
<u>Scrap Value of Plant</u>								0
TOTAL BENEFITS	n/a	238,156	238,156	238,156	238,156	238,156	238,156	238,156
NET PRESENT VALUE (NPV)								
Discount Factors (12%)	(1.0)	(0.8929)	(0.7972)	(0.7118)	(0.6355)	(0.5674)	(0.5066)	(0.4524)

NPV OF TOTAL CASH FLOW (Benefit - Cost) = (+) € 660,426

$$\text{BENEFIT/COST RATIO} = \frac{\text{NPV Benefits}}{\text{NPV Costs}} = \frac{1,086,897}{426,470} = 2.55$$

*Fuel gas in = fuel gas out

Table 5.5

**CALCULATION OF NET PRESENT VALUE
FOR GOVERNMENT ENTERPRISE
(FOR 2 SHIFT/DAY OPERATION)**

<u>Cost Component</u>	<u>Start-up</u>	<u>Year 1</u>	<u>Year 2</u>	<u>Year 3</u>	<u>Year 4</u>	<u>Year 5</u>	<u>Year 6</u>	<u>Year 7</u>
Investment								
Land	10,000							
Materials	72,666							
Labor	19,969							
Operating and Maintenance								
Materials								
1. Consumables								
a. Fuel		*	*	*	*	*	*	*
b. Electricity		15,226	15,226	15,226	15,226	15,226	15,226	15,226
2. Replacements								
a. Parts & Supplies		2,400	4,800	4,800	4,800	4,800	4,800	4,800
Labor		57,100	57,100	57,100	57,100	57,100	57,100	57,100
Incidentals								
1. Transport to Markets		0	0	0	0	0	0	0
Raw Materials								
Feedstock		121,934	121,934	121,934	121,934	121,934	121,934	121,934
TOTAL COSTS	84,665	199,060	199,060	199,060	199,060	199,060	199,060	199,060
Benefit Component								
Value of Outputs								
1. Oil		200,800	200,800	200,800	200,800	200,800	200,800	200,800
2. Char		111,600	111,600	111,600	111,600	111,600	111,600	111,600
3. Gas		*	*	*	*	*	*	*
Scrap Value of Plant								0
TOTAL BENEFITS	n/a	312,400	312,400	312,400	312,400	312,400	312,400	312,400
NET PRESENT VALUE (NPV)								
Discount Factors (12%)	(1.0)	(0.8929)	(0.7972)	(0.7118)	(0.6355)	(0.5674)	(0.5066)	(0.4524)

NPV OF TOTAL CASH FLOW (Benefit - Cost) = (-) € 432,596

$$\text{BENEFIT/COST RATIO} = \frac{\text{NPV Benefits}}{\text{NPV Costs}} = \frac{1,425,731}{993,135} = 1.43$$

*Fuel gas in = fuel gas out

5.5 Socio-Economic and Cultural Feasibility

Regardless of the net present value of the technology, the many constraints on its operation will affect its feasibility. Among them are the following:

- o Availability of materials. Necessity of having a viable national infrastructure
- o Ability to plan in terms of stable economy and currency values
- o Ability to operate without foreign managers present
- o A level of worker productivity, high or low, that can be expected
- o Availability of transportation and other support resources

5.6 Economic Conclusions

Clearly the technology is economically favorable under certain conditions. It appears more economically attractive for the private sector, specifically the lumber industry than for the public sector, assuming comparable economic criteria are applied.

6.0 CONCLUSIONS AND RECOMMENDATIONS

The objective of this program was to demonstrate pyrolysis as a feasible and economical alternative energy source for developing countries. The Economic Development Laboratory (EDL) of the Engineering Experiment Station at the Georgia Institute of Technology proposed to design a technically appropriate pyrolytic convertor system, and construct, test, and evaluate the system in the Republic of Ghana. The project goal was to develop a pyrolytic system that will be commercially acceptable in Ghana and possibly in other developing countries. The system components and the complete system have been tested and debugged. The yields achieved were in accordance with those specified in the design criteria. Ghana today has the knowledge and capability to build and operate a pyrolytic system.

6.1 Conclusions

The project activities and results have led to the following conclusions:

- o the waste materials, energy needs and industrial infrastructure necessary for the effective utilization of pyrolysis exists in Ghana.
- o Saw dust and wood shavings can be successfully pyrolysed producing char, oil and a combustible gas.
- o The yields and quality of these products exceed the estimates. (Operating on a 24-hour basis, would process six tons of feed, and produce 3,000 pounds of char and 2,200 pounds of oil.)
- o The final cost of fabrication of the system was deceptively high due to the development, changes and modifications to the system. The construction of a system using the final design, would be less costly.
- o The economic analysis indicates the wisdom of investing in pyrolysis. The high net present value and attractive cash flow figures are encouraging.
- o Ghana possesses the technical experience and know-how, to build and operate similar systems.
- o The oil produced is of very good quality and it can be used, as is, in the adjoining brick kiln as a Bunker-C fuel substitute.

- o The watery oil collected from the system can be used as a wood preservative/insect repellent. Theses which have been conducted to date show very good results.
- o The powdered char can be used in the existing cookers, blown into burners as a powder coal or L.P. gas substitute, briquetted, or use in brick kilns as a Bunker-C substitute.
- o The extra gas produced could be used in dryers similar to those existing in the pyrolysis system, to dry crops, grain, etc.

6.2 Recommendations

There are in Ghana a large amount of agricultural and forestry wastes that can be pyrolyzed. The waste accumulation in thousands of locations, indicates that small scale, labor intensive pyrolytic units, operating at these locations will be ideal. It will require very little or no transportation, eliminating one of the most serious problems in the country. Based on our findings, our recommendations to operate the system are:

- o In drying saw dust or wood shavings, the dryer should never be filled over one foot deep. The feed should be turned periodically so as to expose the wet material at the top of the bed to the higher temperatures necessary for drying.
- o The system should be operated each day for a period of time long enough to produce the supply of dried feed necessary for operation the following day. The convertors, burners and dryers will operate properly only if the system is using dried feed. If wet feed is used the burners, will not ignite due to the high moisture content (steam) of the offgas, and the convertors will produce a watery oil.
- o The oil collected at different points in the system i.e. the condenser, demister, manifold has varying characteristics, most notably, viscosity and water content. It is recommended that the two main fractions of oil be stored in separate storage containers or vessels. The oil with high water content could be sold as wood preservative/insect repellent, or it could be used to blend with the thicker oil to decrease the viscosity, if necessary.

A logical choice would be to locate a pyrolysis system in a sawmill, where there would be an ample amount of feed material. As long as the pyrolysis system

is maintained and operated by a government institution the business sector will consider the system a research apparatus. Once a single pyrolysis system is operated by private company or individual, the hesitancy in the private sector to invest in the system will diminish. A private owner/operator would also give the system the attention and control necessary to ensure the pyrolysis system meets or exceeds the design criteria.

APPENDIX A
Engineering Drawings and Bill of Materials

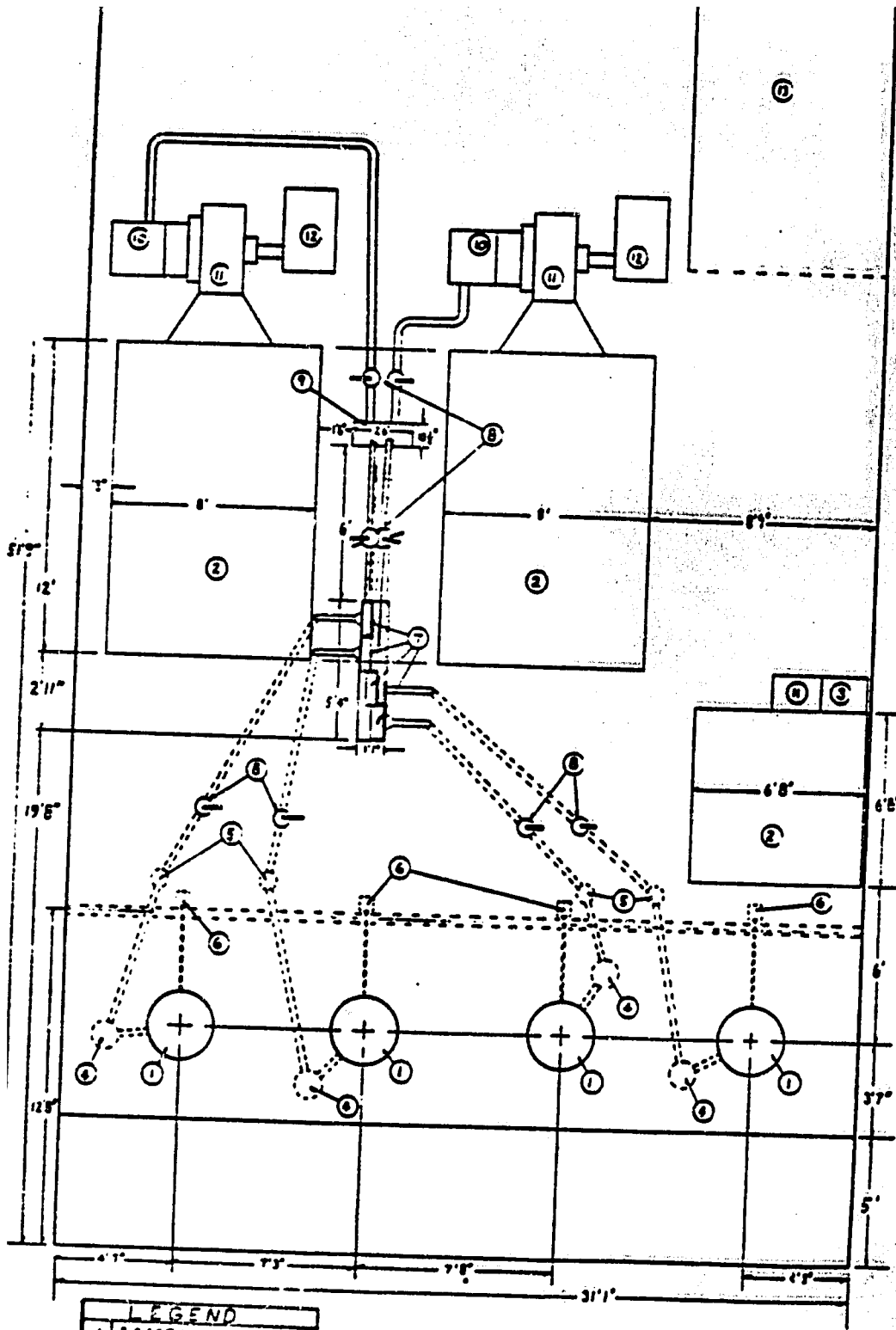

LEGEND	
1	REACTOR VESSEL
2	DRYER
3	AEROSOL BURNER
4	CONDENSER
5	HEAT EXCHANGER
6	WINDHAMMER
7	SCAVENGER FANS
8	3" VALVES
9	MANIFOLD
10	GAS BLANDED
11	BLOWER
12	ELECTRIC MOTOR
13	FRAME

PLANT LAYOUT TOP VIEW

Ghana Pyrolysis System	
Drawing 1/1	
Drawn By: W. D. K. A. R. E. S.	Date: 9/1/73
Approved By: [Signature]	Date: 9/20/73

LEGEND	
1	REACTION VESSEL
2	DRYER
3	KEROSENE BURNER
4	CONDENSER
5	DEMISTER
6	WINDJAMMER
7	SCAVENGER FANS
8	3" VALVES
9	MANIFOLD
10	GAS BURNER
11	BLOWER
12	ELECTRIC MOTOR
13	RAMP

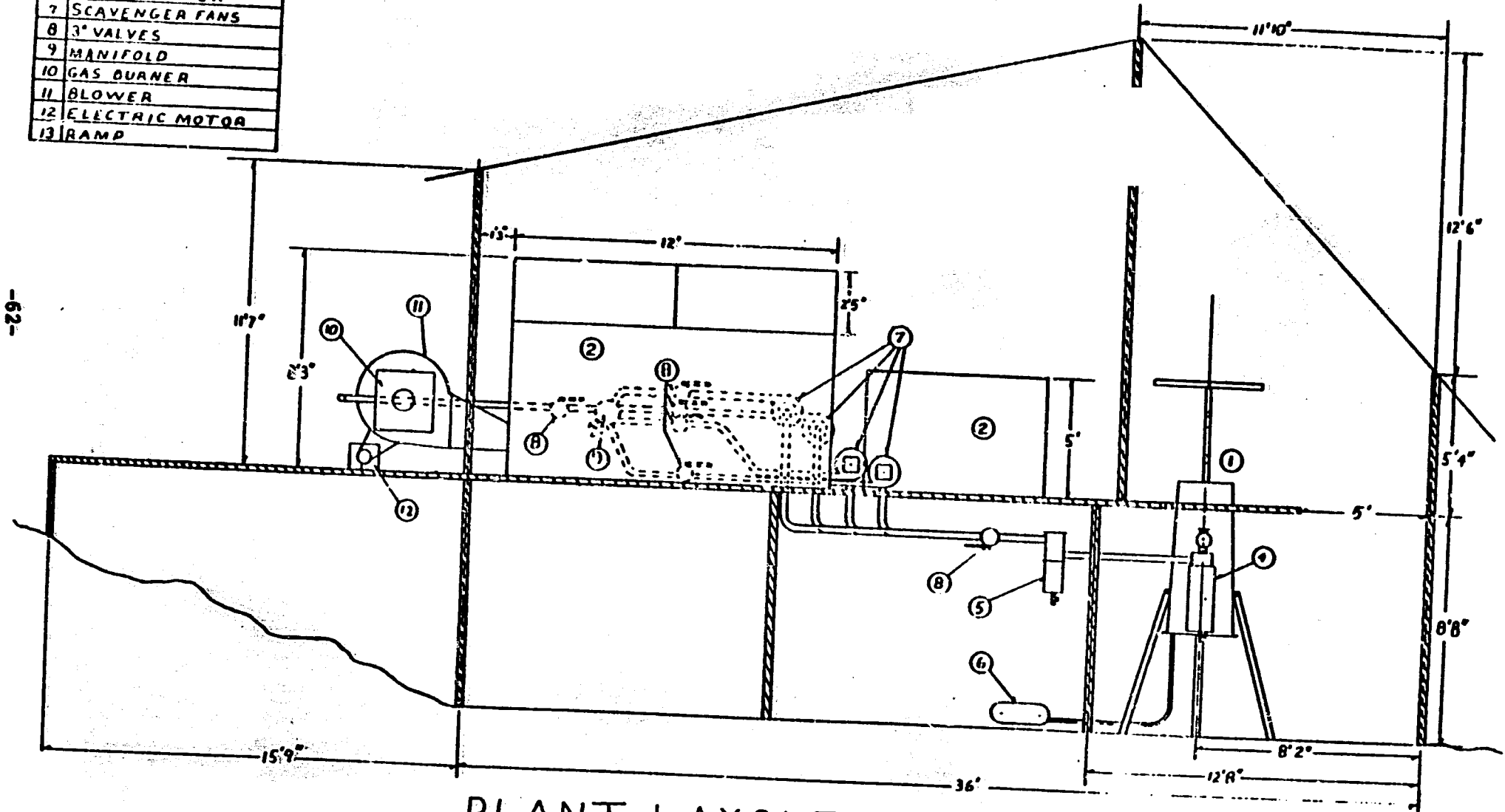

PLANT LAYOUT
SIDE VIEW

Ghana Pyrolysis System	
Drawing # 2	
Drawn By: W D KAHRFS	Date: 7/1/68
Approved By: J.S.	

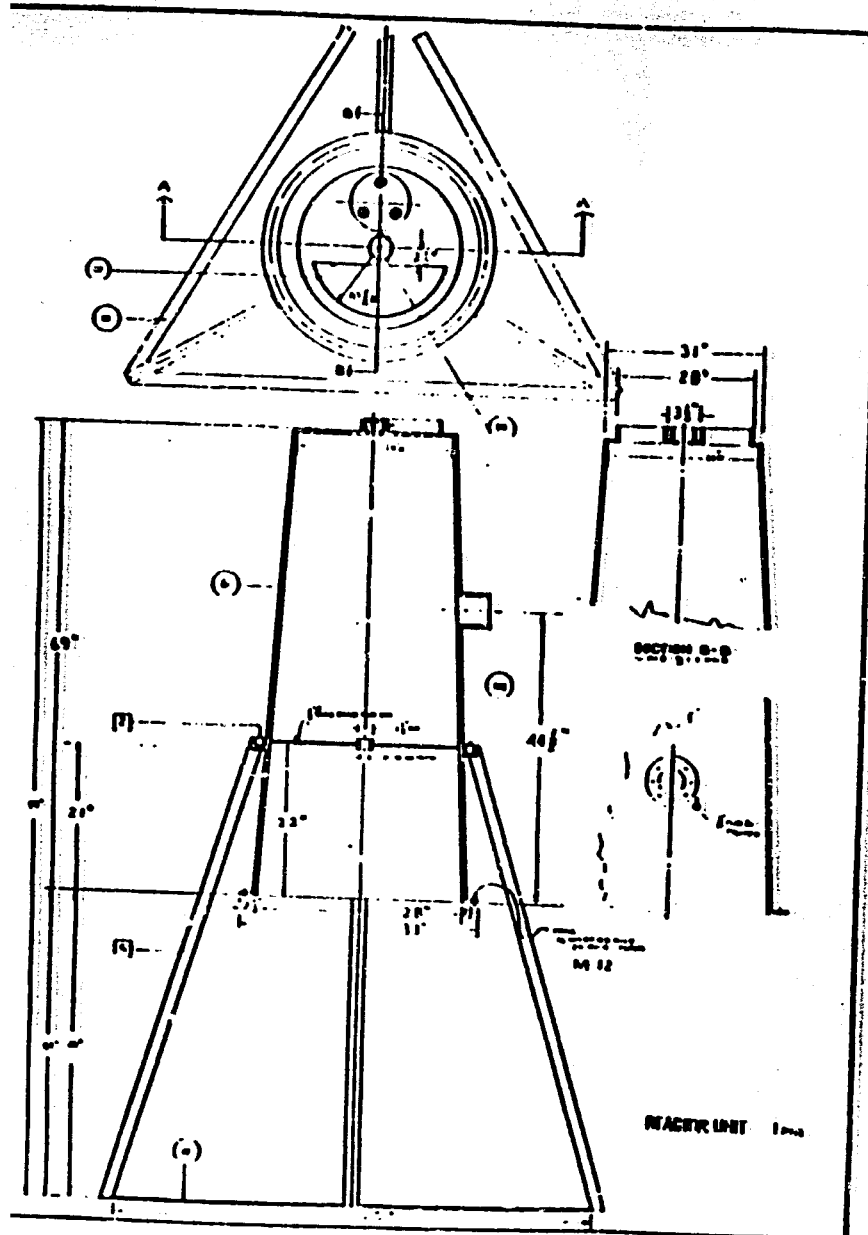

PART NO. 19
TOP VIEW

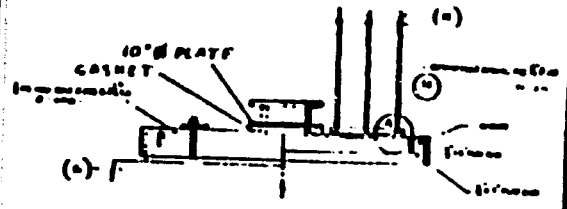
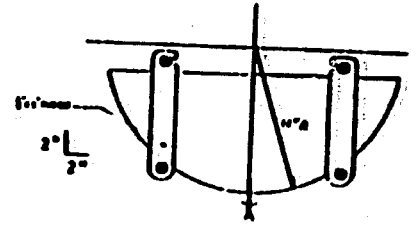

Ghana Pyrolysis System	
Drawing # 1	
Drawn By: W D KAHRES	Date: 1/15/67
Approved By: [Signature]	Date: 9/1/67

74

Ghana Pyrolysis System	
Drawing # 6	
Drawn By: W. D. KAIRES	Date: 9/11/60
Approved By: [Signature]	Date: 9/20/60

PART NO. 1
PEEBLE BED SHAKER ARM ASSEMBLY & PIPING SYSTEM

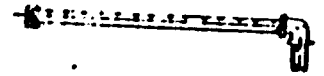
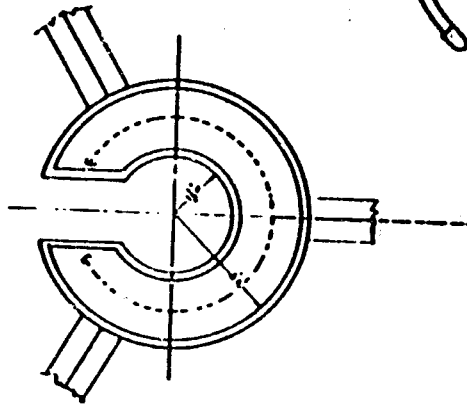
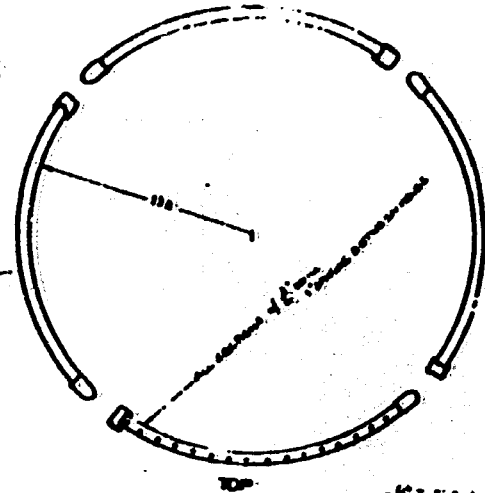
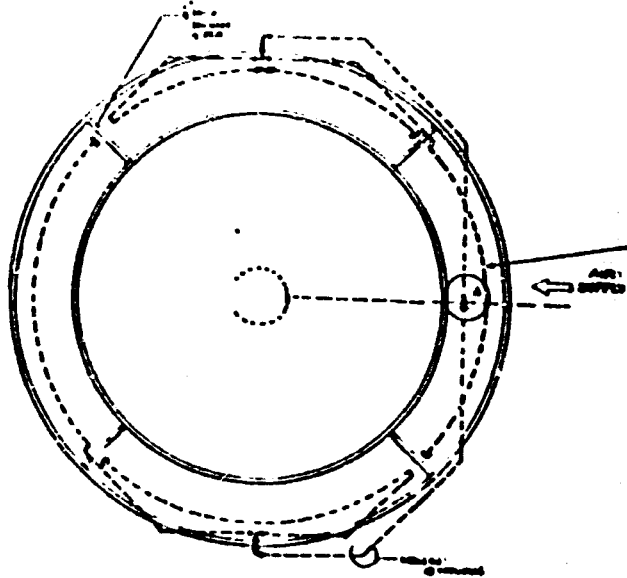

PIPING DRAWING

LEGEND:

1" PIPE	----
CAP	⊖
ELBOW	⌋
TEE	⊥
OR PIPING	⊙

-99-

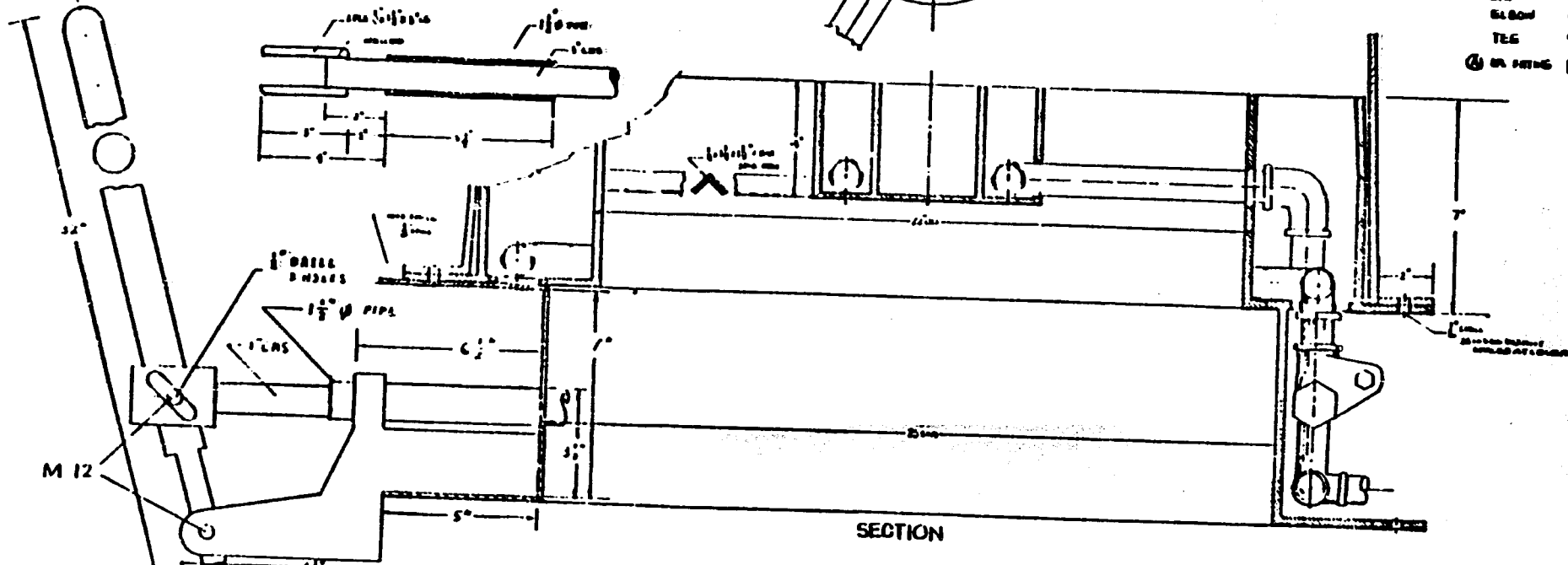

SECTION

66

PART NO 9
GRATE - 1 REQ

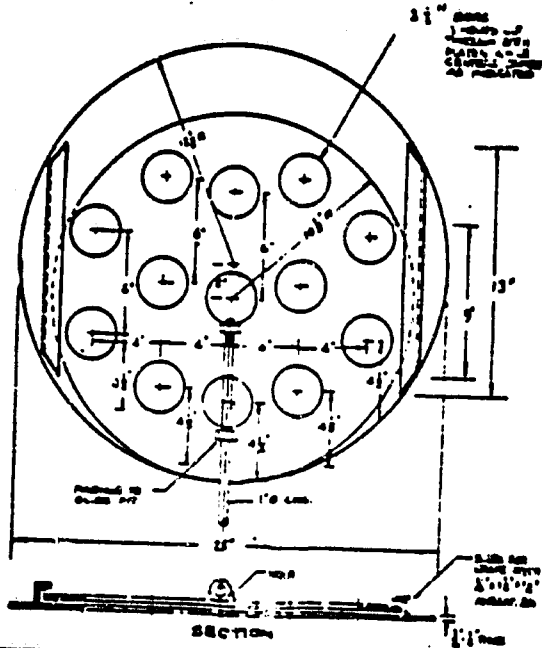

PART NO 20
PADDLE - 1 REQ

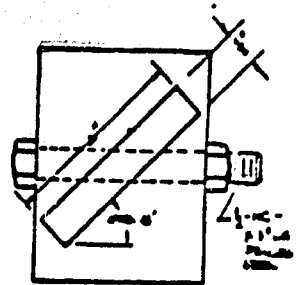
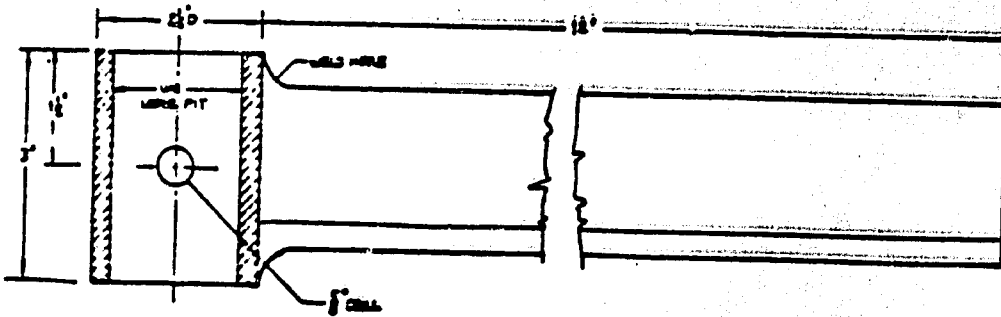

Ghana Pyrolysis System	
Drawing 17	
Drawn By: W D KAHRES	Date: 9/11/82
Approved By: [Signature]	Date: 9/20/82

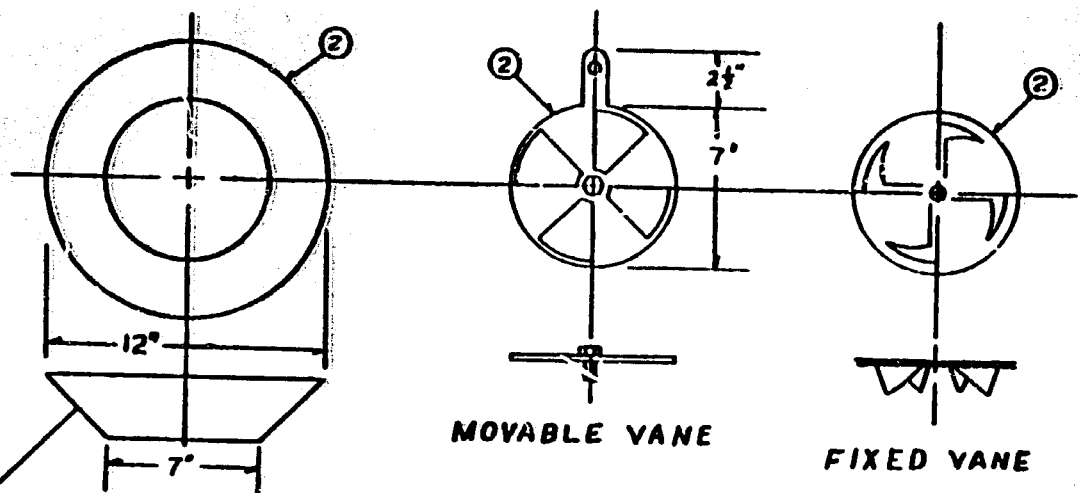

BURNER FOR DRYER

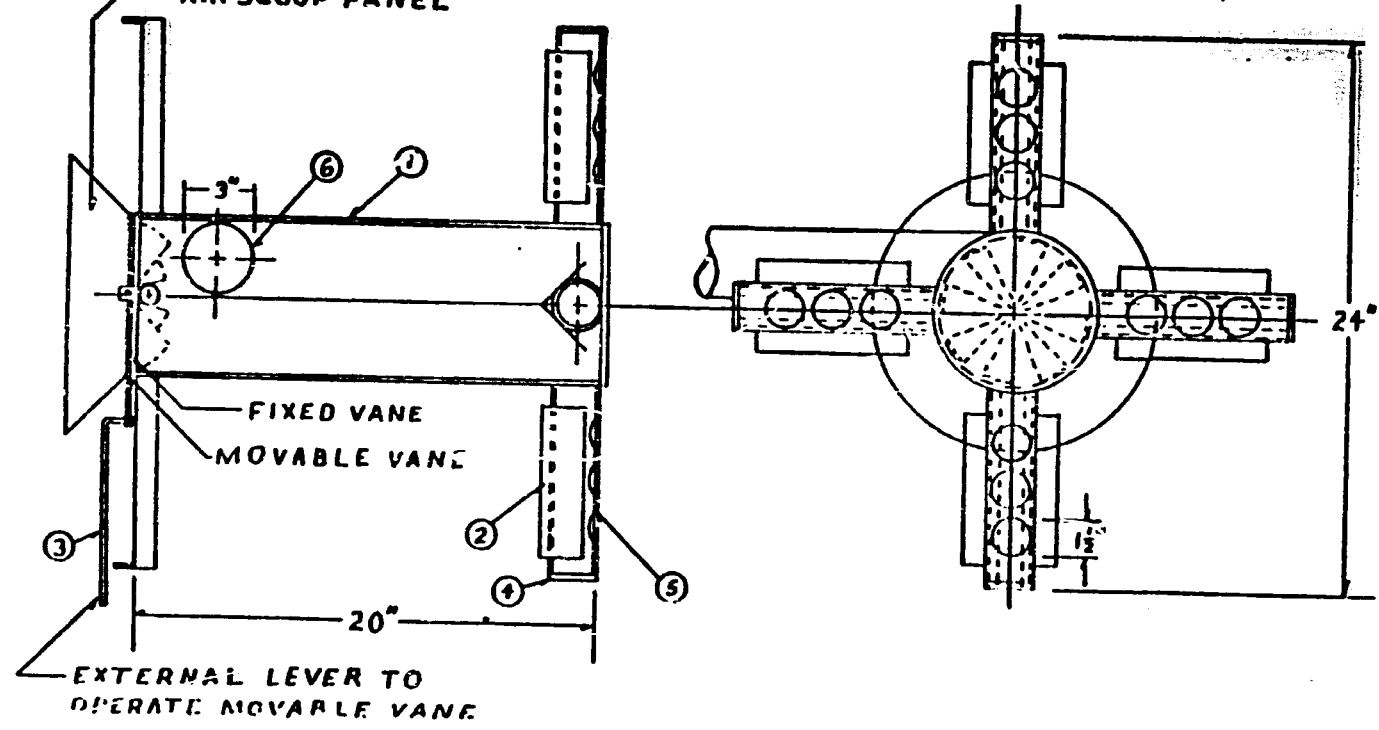

BILL OF MATERIALS	
NO	DESCRIPTION OF MATERIALS
①	7" DIAMETER STEEL PIPE
②	16 GAGE SHEET STEEL
③	1/2" DIAMETER STEEL ROD
④	1/8" SHEET STEEL
⑤	3" DIAMETER STEEL PIPE
⑥	3" DIAMETER STEEL PIPE

Ghana Pyrolysis System	
Drawing 18	
Drawn By: W D KAHRES	Date: 11/14/60
Approved By: [Signature]	Date: 2/1/60

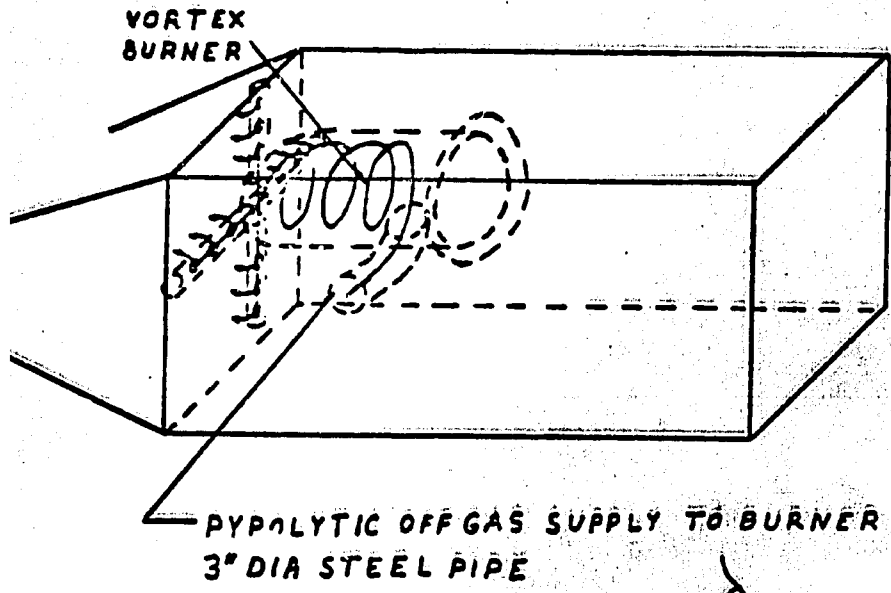

BURNER AND BLOWER FOR DRYING UNIT

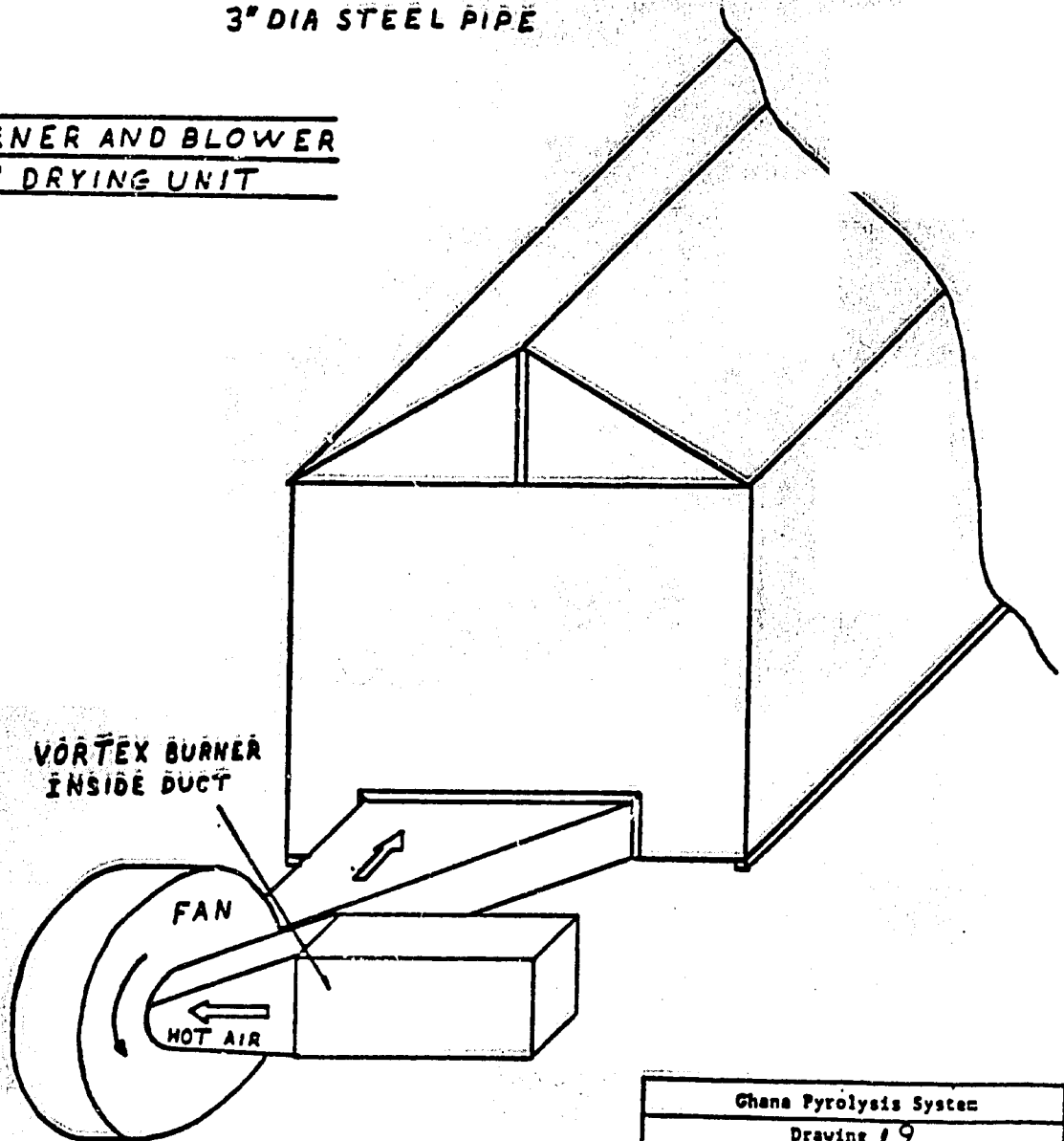

Ghana Pyrolysis System	
Drawing 19	
Drawn By: W D KAHRES	Date: 9/18/80
Approved By: [Signature]	Date: 9/20/80

-70-

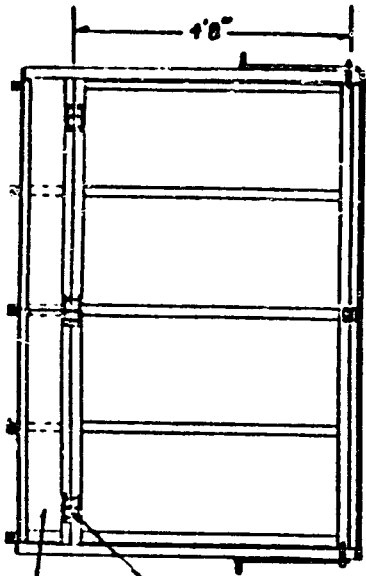

REMOVABLE PANELS FOR CLEANING

⑥

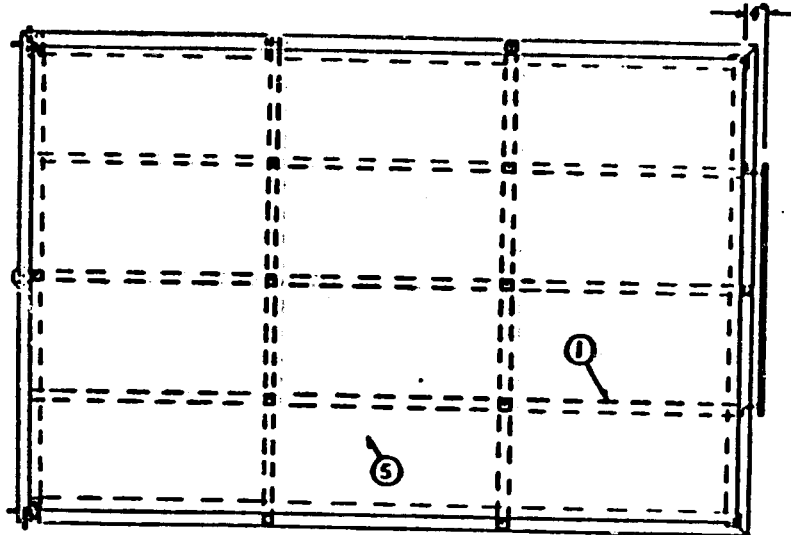

①

⑤

②

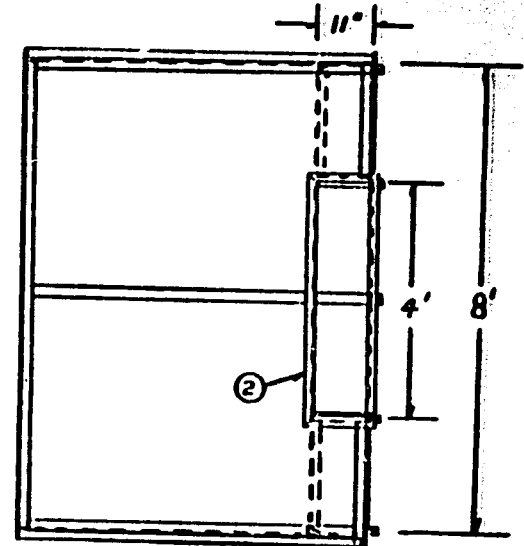

②

DOOR SERVES AS RAMP

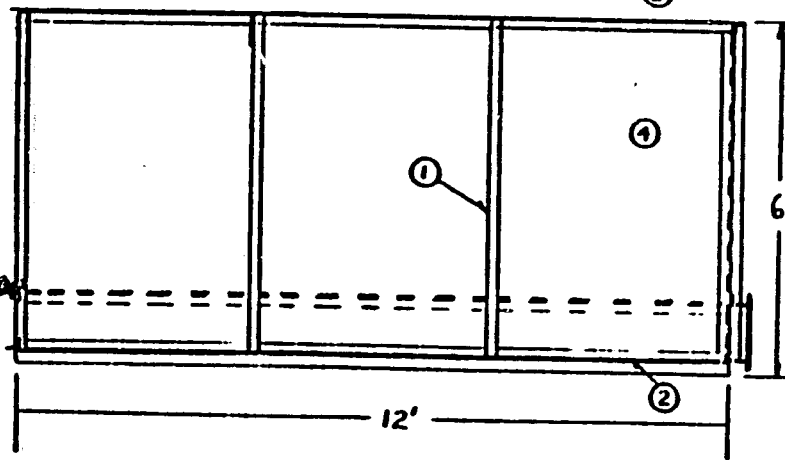

①

④

②

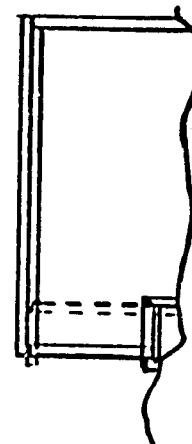

BILL OF MATERIALS	
NO	DESCRIPTION OF MATERIAL
①	2x2 OR 1 1/2x1 1/2 BOX (SQUARE) TUBING
②	2"x2"x 1/2 OR 1 1/2"x1 1/2" STEEL ANGLE
③	1" THICK PLATE FOR LATEN FABRICATI
④	SHEET METAL COVERING 36"x48"x 1/8
⑤	SHEET METAL FLOORING ABOUT 6"
⑥	HINGES

Chem Pyrolysis System	
Drawing # 10	
Drawn By: W D KAHRES	Date: 9/11/50
Approved By: [Signature]	Date: 9/11/50

BILL OF MATERIALS

4	1" Dia. Pipe
5	#26 Galvanized Iron Sheet
6	3/16" - 1/4" Thick Low Carbon Steel Plate
7	#26 Galvanized Iron Sheet
8	3/16" - 1/4" Thick Low Carbon Steel Plate
9	3/16" - 1/4" Thick Low Carbon Steel Plate
11	55 Gallon Drum
12	3 1/2" Dia. Pipe
13	2 1/2" Dia. Pipe
14	10" L.G. Compression Spring
15	1/16" - 3/32" B.I. Sheet
16	1/4" x 1" x 1" Angle Bar
17	8" Dia. Pipe
19	3/16" - 1/4" Low Carbon Steel Plate
101	3 1/2" Dia. Coupling & Plug
102	1/4" - 1/16" Thick x 2" O Pipe
104	3 1/2" Dia. Pipe x 5" L.G.
105	1 1/4" Elbow
106	1 1/4" Valve
107	1 1/4" Tee
108	M-12 Bolt
110	1/2" Coupling and Plug
111	12: x 24" Fine Screen
122	1/4" - N.C. - 16" x 3 1/2" L.G. Hex Bolt and Nut
123	1/4" x 2" Flat Bar
S	1/4" x 2" x 2" Angle Bar
T	10" Dia. Pipe
W	1/4" x 2" Flat Bar
X	3 1/2" Dia. Pipe
Y	3/16" - 1/4" Thick Flanges Plate
Z	1" Dia. Pipe

APPENDIX B
OPERATIONS AND MAINTENANCE MANUAL

THIS PYROLYTIC REACTOR SYSTEM HAS BEEN DESIGNED TO OPERATE AS SIMPLY AND SAFELY AS POSSIBLE. THE STARTUP AND OPERATIONAL STEPS DESCRIBED IN THIS MANUAL ARE ESSENTIAL TO SAFE AND PRODUCTIVE PROCESSING OF SAW DUST OR OTHER WASTE MATERIALS. THE REACTOR HAS BEEN DESIGNED TO PROCESS SAW DUST AND WOOD SHAVINGS. CONVERSION TO OTHER WASTE MATERIALS REQUIRES DESIGN MODIFICATIONS FOR SAFE AND PROPER OPERATION.

THE REACTOR OPERATES AT HIGH TEMPERATURES AND PRODUCES GAS, OIL, AND CHAR ALL OF WHICH ARE FLAMMABLE.

FIRE OR EXPLOSION CAN OCCUR IF PROPER STARTUP AND OPERATION PROCEDURES ARE NOT FOLLOWED EXACTLY AT ALL TIMES!

I. REACTOR STARTUP

Preliminary

- a) Perform a visual inspection of the convertor that you are going to start to check for damage and/or loose fittings.
- b) Make sure all the flange and pipe connections are tightened.
- c) Make sure that the agitator turns freely.
- d) Open the door at the top of the reactor.
- e) Hand check all pressure relief ports to make sure that they open and close freely.
- f) Install an empty char barrel in the bottom of the reactor and firmly tighten the retaining nuts.
- g) Close the char grate.
- h) Place the filter in position and close and tighten the filter port.
- i) Install thermometers.
- j) Make sure the primary air valve is closed.
- k) Open all secondary air valves.
- l) Make sure valves controlling the flow of oil from the jet condenser and demister are closed.
- m) Make sure that all thermometers and gauges in their respective places.
- n) Adjust pressure gauges so that it reads "0" at ambient pressure.
- o) Adjust the thermometer controls of the reactor so that they read the ambient temperature.
- p) Make sure that the manifold-out valve is closed.

Char Bed Formation

Through the port at the top of the reactor, add enough powdered or granulated char to fill up the space between the grate to 1 or 2 inches above the pebble bed. (If powdered or granulated char is not available, use sawdust or wood shavings.)

Start-UP

After checking the whole system seeing that everything is properly assembled; do the following to the reactors you are planning to fire one at the

time:

- o Close the main valve of the air supply
- o Open full all secondary air supply valves (the ones around the pebble bed)
- o Close demister discharge valve
- o Close the two manifold discharge valve
- o Open feed door (hatch) and load enough feed or sawdust to cover the pebble bed by 1 or 2 inches.
- o Insert fire into the reactor, i.e. a piece of burning rag or paper.
- o Start wind jammer blower.
- o Open main air supply valve 1/4 turn.
- o Open demister discharge valve full open.
- o Regulate main and secondary air supply valves so as to create flames inside of the reactor and to propagate them uniformly all around the pebble bed.
- o Add a sack of feed.
- o Open the manifold discharge valves(s) to control the flow of gas into either or both burners(s)
- o Once the feed is burning and is evenly spread, (a thick white smoke, at times yellowish will come out in large quantities of the feed port), fill the reactor to the top; close and secure the trap door.
- o Start scavanger fan for appropriate reactor.
- o Start-up has been completed. Caution: Scavanger fans should always be started after and turned off before the windjammer to eliminate the possibility of having negative pressure in the reactor which will suck air into the reactor and could result in an explosion.

Reaching Pyrolytic Operating Temperature

- a) When the thermocouple readings around the reactor vessel are within about ten (10) percent of each other, shake the char grate briefly. Take additional temperature readings in each quadrant and make further adjustment of the secondary air valves if an unbalance of more than ten (10) percent exists.
- b) After uniform combustion has been established, increase airflow by opening the primary air valve to a differential pressure reading of 0.4 inches of water.

- c) The desired range of operating temperatures is 800 to 1200 °F. If the rate of increase toward this temperature range is very slow, increase the primary airflow to a differential pressure reading of 0.8 to 1.0 inches of water. When the reactor temperatures reach 600 to 800°F, the primary airflow should be reduced slightly in attempt to prevent overshoot of the desired operating range.

II. OPERATION

- a) Reactor temperatures at the level just above the pebble bed should be maintained in the range 800 - 1200 °F.
- b) The temperature measured at the input (reactor side) of the condenser should be between 200 ° and 350 °F. This temperature is primarily a function of the reactor temperature and airflow but can be expected to vary during char removal and introduction of feedstock.
- c) The temperature exiting between the condenser and the demister should be in the range 180 - 215 °F. Lower temperatures will increase the water content of the oil beyond desirable levels. Higher temperatures will allow oil fractions to be retained in the gas stream.

Temperature Control

Five valves control the flow of air to the reactor and hence the operating temperatures. The primary valve located between the input blower and the reactor is monitored by a differential pressure gauge and is the main reactor control as previously discussed. Air is fed from the main line to the reactor through four separate systems. Each quadrant has a valve which can be used to adjust the relative airflow in that quadrant. The valve is located in the middle of the quadrant and controls the air to the sector measured by that probe. Airflow is increased by turning the valve counter clockwise facing the reactor and decreased when the valve is turned clockwise. Should a hotspot (coldspot) develop after a period of stable operation, the airflow should be decreased (increased) in that particular quadrant until uniform temperatures are restored. If this doesn't solve the situation, open the feed door and try poking it.

IMPORTANT

IF REACTOR TEMPERATURES EXCEED 1900 °F OR IF THE SYSTEM OPERATES IN ANY UNUSUAL MANNER, THE PRIMARY AIR VALVE SHOULD BE CLOSED BEFORE ANY ATTEMPTS TO REMEDY THE PROBLEM ARE MADE.

IN CASE OF LOSS OF POWER TO THE INPUT BLOWER, THE PRIMARY AIR VALVE SHOULD BE CLOSED IMMEDIATELY.

IF THE REACTOR IS SHUT DOWN FOR MORE THAN ONE HOUR FOR ANY REASON, THE FILTER MUST BE REMOVED CHECKED AND CLEANED IF NECESSARY. THE DIAL THERMOMETER BETWEEN THE REACTOR AND THE CONDENSER MUST BE REMOVED BEFORE THE FILTER IS EXTRACTED FOR CLEANING.

Char Removal

Char needs to be removed periodically. To do this shake the grate handle about 50 times for each 1½ lbs. of char to be produced.

Changing Char Barrels

Char barrels should not be changed while the reactor is in operation unless they are full. With the grate closed, open the small valve at the top of the char barrel. A full barrel is indicated if there is no noticeable escaping gas. If the barrel is not full, significant gas will be released. Close the valve. To change a full barrel,

- a) Check that the grate is closed.
- b) Stop scavenger fan.
- c) Close the primary air valve.
- d) Loosen the six retaining bolts holding the barrel to the reactor
- e) Remove the char barrel and cover with an airtight lid.
- f) Replace with an empty barrel.
- g) Secure the barrel to the reactor by tightening the retaining bolts.
- h) Open the primary air valve and adjust the flow to obtain desired pressure reading.
- i) Start scavenger fan
- j) Resume normal operation.

The change should be made as expeditiously as possible, consistent with safety, to minimize the disruption of reactor operation.

Oil Removal

The primary oil collection is performed by the condensers. Oil can be removed every thirty minutes or so by opening the valve at the bottom of the condensers and draining the oil into a suitable container. The demister which follows the condenser in the offgas line serves as a safeguard to make sure that most of the oil is condensed from the exit gas. To drain the demister, simply open the valves at the demister bottom.

III. REACTOR SHUTDOWN

- a) Turn off the appropriate scavenger fan
- b) Turn off the primary air valve.
- c) Turn off the input blower. (This sequence a, b, c, must be strictly enforced)
- d) Shake the grate so as to empty the contents of the reactor into a char barrel.
- e) Upon filling the char barrel, replace it with an empty one.
- f) Repeat the above procedure until the reactor is empty.
- g) Make sure that each drum full of feed material and/or char is tightly sealed to avoid a fire hazard.
- h) Empty the jet condenser and the demister.
- i) Remove the dial thermometer which measures the input temperature to the jet condenser.
- j) Remove the filter check it and clean it if deemed necessary.

The pyrolytic convertor is now shut down.

IV. STAND BY MODE

If the system is to be stopped for a period of time not exceeding 24 or 30 hours. The stand by mode is appropriate and time saving.

Follow shutdown procedure III a, b, and c when operation is to be continued:

- a) Start windjammer blower (input)
- b) Open primary air valve

- c) Start scavenger fan
- d) Follow the instructions "Reaching Pyrolytic Operating Temperature"

Caution: At all times remember that there is burning feed inside of the reactor.

V. START GAS BURNER(S)

- o When the gas being produced turns yellowish, try lighting it. Use a lighter, burning paper etc. The gas will ignite easily. This often happens before reaching operation temperatures in the reactor (800°F - 1200°F and 220 to 350° in the off gas).
- o Once the burner is lit let it burn for about 1/2 hour until burner gets red hot. Then turn on the blowers (by the dryers).

Caution: Most of the time you cannot see the flame in the burning gas, so don't get near it when the blowers are not functioning, (flames will come out the rear of the burners). You will know that it is burning if the yellowish cloud of smoke coming into the burner disappears. If you are not sure, probe with a long piece of paper, to see if it burns.

- o Once you start the blowers check the thermometers that monitor the temperature of the burners and try to maintain an input air temperature of about 250 °F into the dryers. You can control this by regulating the valves controlling the flow of gas into the burners.

VI. ROUTINE MAINTENANCE

Filter

After every run, the filter should be removed from the reactor and thoroughly inspected. Clean it if deemed necessary. A simple way of cleaning is to slowly rotate the filter over an open fire, burning off the heavy tars. Then use a steel brush to remove any build-up of carbon on the filter. Visually inspect the filter holes for any deposits and reclean if necessary.

Filter Sheath

When necessary, the sheath for the filter should be cleaned by first removing the filter and then inserting a steel brush with a long handle.

The insides of the sheath should be thoroughly scrubbed with the brush (especially that section penetrating the reactor) to remove any carbon build-up.

Jet Condenser

The jet condenser is mostly self-cleaning due to the moderately high operating temperatures. However, if the reactor has been shut down for several days, the inner pipe of the condenser should be removed and cleaned making certain that the 120 holes are not obstructed.

Lubrication

The following objects should be kept lubricated on the pyrolytic convertor:

- a) All motors and shafts as specified by manufacturer.
- b) The rod connecting the grate to the handle.
- c) The section of the agitator that touches and passes through the reactor.

Gaskets

Gaskets should be routinely checked and those that appear worn should be replaced.

VII. DIAGNOSIS AND TROUBLE SHOOTING

In the event that the reactor deviates from its normal operating conditions, this section will help the operator analyze and solve the problem.

Below are listed several possible malfunctions along with the procedures necessary to rectify them.

a) Agitator Too Easy to Turn

The bed depth could be below the top blade. Add more feed to the reactor.

If the bed depth is correct, the blade has been bent or has been sheared off. In this case:

- 1) Shut off the system following instructions in Section III.
- 2) Empty the convertor.
- 3) Allow the convertor to cool.

4) Drop the pebble bed following the instructions in Section VII.

5) Repair the damage.

b) Grate Cannot Be Shaken

a) The rod connecting the handle to the grate needs to be lubricated.

b) Connecting rod is bent

c) The char is jamming the grate. Drop pebble bed and examine it.

c) Low Reactor Temperatures

If the reactor is still in a start-up mode, continue normal start-up procedures.

If the reactor has been at full operating temperature, check the primary airflow. If it has dropped, open the primary air valve to adjust to the original pressure reading.

Check for smoke or gas being emitted from the reactor. If none is present, open primary air valve full until smoke or gas is visible. If after a period of time no smoke is seen and reactor temperatures continue to drop, the reaction in the reactor has stopped. Shut off the primary valve, activate the grate to drop the bed depth down to the pebble bed and go through the start-up procedure.

d) High Reactor Temperature

Reduce the airflow. Shake the grate to lower the char bed. Stop shaking the grate when the condenser input temperature begins to drop.

If the grate appears very easy to shake and the reactor temperature and the condenser input temperature continue to increase, then a cavity has been formed. Stop the scavenger fan, close the primary air valve, open the top of the reactor, and with a long metal or wooden rod, poke the bed being careful not to strike the thermocouple wells. Then close and seal the top, and resume operation.

e) Uneven Reactor Temperatures

Using the secondary air valves, either open or close them to equalize the temperature. Opening a secondary air valve will

increase the temperature of a particular quadrant and closing it will decrease the temperature.

f) Low Condenser Input Temperature (under 200°F)

If the reactor is in the start-up mode, proceed normally.

If temperatures have fallen from normal, increase the primary airflow. Watch for an increase in reactor temperatures. If the condenser temperature continues to fall, if there is no smoke or gas coming from the off-gas stack, and if the reactor temperatures continue to fall, the pyrolysis reaction has stopped. Repeat the start-up procedure.

g) High Condenser Input Temperature (over 400°F)

If the increase in temperature has been sudden, there is probably a cavity in the reactor close the demister discharge valve by 1/2 turn. Close the secondary air feed valve under the off-gas port. Begin processing char by shaking the grate handle. If the temperature doesn't drop turn off the primary air valve, open the hatch at the top of the reactor and poke the bed, being careful not to harm the thermocouple wells. Close and seal the hatch and resume operation.

If the input condenser temperature has gradually increased to a high temperature, open the grate and begin processing char.

h) Low Condenser Output Temperature

Follow Section VI, Step f, in order to increase the temperatures.

j) High Condenser Output Temperature

Check to see if gasification is taking place (sudden increase in reactor temperatures, a sudden increase in condenser input temperature, and a sudden drop in oil yields). If these factors are present, look for signs of cavities. If found follow procedure V, step g).

If gasification is not occurring and all other temperatures are normal, add some water to the condenser insulating shield to reduce the output condenser temperature.

j) Pressure Relief Ports on Reactor Consistently Opening

The pressure is too high inside of the reactor. Check primary air valve for proper reading in the magnehelic gage. If this doesn't solve the problem, check the filter it could be clogged, if so, it should be removed and thoroughly cleaned. If the problem is not solved, go to step k.

k) Pressure Relief Port on Condenser Consistently Opening

The jet section (120 holes) of the condenser are clogged. The jet condenser should be disassembled and thoroughly cleaned.

l) Leaks

All leaks, especially those in the reactor, should be immediately sealed. Leaks of any size cause a loss in product which translates to lower char, oil, and gas yields.

VIII. DISASSEMBLY OF PYROLYTIC CONVERTOR

(Refer to drawings in Appendix A)

a) Char Barrel

The char barrel can be removed from the convertor system by loosening the six bolts holding the char barrel to the reactor and twisting off the barrel.

b) Pebble Bed

The pebble bed can be removed from the convertor system by loosening the 36 nuts and bolts that hold it to the reactor. Care must be taken in dropping the pebble bed so that it lowers evenly from the reactor. Four or five people holding onto the pebble bed will insure a smooth removal.

c) Agitator/Stirrer

The agitator can be removed from the reactor after the pebble bed is out by removing the nuts and bolts holding the blade(s) to the agitator. The agitator should then be pulled straight up and out from the top of the reactor.

d) Jet Condenser

The jet condenser can be unbolted from both the reactor and demister by loosening the nuts and bolts at the respective flanges. The condenser is disassembled by pulling out the inner pipe.

f) Demister

The demister can be disconnected from the jet condenser by loosening the bolts at its respective flange. It can be opened by loosening the top bolts and lifting off the cover. This will expose the screen and lathe shavings in the demister.

APPENDIX C

Test Data

BUILDING AND ROAD RESEARCH INSTITUTE
 PYROLYTIC CONVERTER

DATE: 8/23/78

TEST No. 1

RECORDED BY: KEN YEDOM

CONDITIONS: 7% Moisture Content (Wood Shavings)

TIME	REACTOR	TEMPERATURES		COMMENTS	ADD FEED	IN. OF H ₂ O
		COND. IN	COND. OUT		LB.	AIR FLOW
10:00 a.m.	-	-	-	Crank with 41.0 lb. of feed	41.0	0.1
10:30 a.m.	-	150	140	Stopped to check Jamming of capstan arm	-	-
11:00 a.m.	-	-	-	Crank again with reactor filled to maximum capacity	35.5	-
					30.5	0.1
11:30 a.m.	-	150	140		40.0	-
12:00 p.m.	-	150	142	-	-	0.1
12:30 p.m.	200	152	142	-	-	0.1
1:30 p.m.	200	152	142	-	-	0.1
2:30 p.m.	250	158	148	-	-	0.1
2:45 p.m.	300	185	160	Worried about temperature hence increased pressure Stopped for poking. Add feed	37.5	0.2
					35.0	0.2
3:05 p.m.	300	205	160	Detected hot spot, hence stopped for poking	32.5	-
3:20 p.m.	250	200	164	-	-	0.2
3:45 p.m.	300	195	160	-	-	0.2
4:00 p.m.	300	205	164	-	-	0.2
				Temps. remain constant for a long time hence decided to increase air flow	-	0.3
4:15 p.m.	400	350	205	Stop and add feed	30.0	-
4:50 p.m.	450	340	204	Stop, poke, and add feed	36.00	0.3
5:00 p.m.	500	340	204	Stop and add feed	37.0	0.3
5:25 p.m.	600	350	200	Stop and poke and add feed	36.5	0.3
5:30 p.m.	625	340	192	-	-	0.3
5:45 p.m.	690	325	196	-	-	0.3
5:50 p.m.	700	325	196	-	-	0.3
6:20 p.m.	725	325	180	Processed 1/6 of barrel and add feed	38.5	0.3
6:50 p.m.	750	350	190	Stop, poke and add feed	37.5	0.3
7:30 p.m.	800	355	200	Poke and add feed	37.5	0.3
					-	0.3

-96-

91

BUILDING AND ROAD RESEARCH INSTITUTE
 PYROLYTIC CONVERTER
 (Continued)

DATE: 8/23/78

TEST No. 1

RECORDED BY: KEN YEBOAH

CONDITIONS: 7% Moisture Content (Wood Shavings)

TIME	REACTOR	TEMPERATURES		COMMENTS	ADD FEED	IN. OF H ₂ O
		COND. IN	COND. OUT		LB.	AIR FLOW
7:45 p.m.	825	350	200	Stop, poke, and add feed	35.0	
8:05 p.m.	800	235	190		36.5	0.3
8:15 p.m.	800	310	194	Process again	-	0.3
8:20 p.m.	800	310	194	Excessive loss of gas at reactor pressure relief port	-	0.3
8:30 p.m.	775	357	202	Decided to stop due to excessive loss of oil	-	0.3

CONDITIONS:

1. Jet condenser
2. Position of off-gas pct - Lowest
3. Oil yield - 2 1/2 gallons (4.6%)
4. Weight of char - 136 lb.
5. Weight of feed - 614 lb.
6. Weight of feed dry basis - 571 lb.
7. Char yield - 24%

BUILDING AND ROAD RESEARCH INSTITUTE
PYROLYTIC CONVERTER

DATE: 8/31/78

TEST No. 2

RECORDED BY: KEN YESOAN

CONDITIONS: 7% Moisture Content (Wood Shavings)

TIME	REACTOR	TEMPERATURES		COMMENTS	ADD FEED	IN OF H ₂ O
		COND. IN	COND. OUT		LB.	AIR FLOW
9:45 a.m.	-	-	-	Start with 39.5 lb. of feed	38.5	0.1
10:15 a.m.	-	135	115	Stop and add feed	37.5	0.1
					34.5	0.1
10:45 a.m.	-	160	142		38.5	
11:15 a.m.	-	165	150		37.5	
11:30 a.m.	205	162	144		-	0.1
11:45 a.m.	210	165	150	Decided to increase air flow	-	0.1
11:55 a.m.	210	-	-		-	0.2
12:08 p.m.	-	-	-	Minor power failure hence turned main valve off.	-	0.2
12:13 p.m.	-	-	-	Crank again	-	-
12:40 p.m.	-	-	-	Power failure again	-	0.2
1:05 p.m.	255	200	162	Crank again	-	0.2
1:30 p.m.	265	170	150	Smoke turns white (Hot Spot), stop poke and feed	35.0	0.2
1:45 p.m.	280	200	160	Require increase in temp. hence increase Air Flow	36.5	0.2
2:30 p.m.	280	210	161	Hot Spot, Stop, poke and feed	-	0.3
3:00 p.m.	275	205	160		38.5	0.3
3:15 p.m.	280	225	152	Poke and feed	32.5	0.3
3:45 p.m.	300	280	160	Not happy about color of gas	-	0.3
4:00 p.m.	360	325	175	Poke and feed	39.5	0.3
				Stop, poke to feed	38.5	0.3
				Started taping useful oil	37.5	0.3
					-	0.3

BUILDING AND ROAD RESEARCH INSTITUTE
 PYROLYTIC CONVERTER
 (Continued)

DATE: 8/31/78

TEST No. 2

RECORDED BY: KEN YESSAN

CONDITIONS: 7% Moisture Content (Wood Shavings)

TIME	REACTOR	TEMPERATURES		COMMENTS	D. FEED LB.	IN. OF H ₂ O AIR FLOW
		COND. IN	COND. OUT			
4:10 p.m.	400	340	180			
4:15 p.m.	600	410	190			0.3
4:45 p.m.	690	375	185	Temperatures too high hence decrease of flow.		
5:15 p.m.	700	325	180	Stop and feed		0.2
5:45 p.m.	705	320	180		38.5	0.2
6:20 p.m.	725	325	175	Start processing		0.2
				Stop and feed		0.2
6:30 p.m.	720	320	175		30.0	
7:00 p.m.	730	350	182	Increase flow again	35.5	
7:30 p.m.	780	350	200	Stop and feed		0.3
7:45 p.m.	800	345	190		30.5	0.3
8:00 p.m.	805	350	195	Process again		0.3
8:30 p.m.	800	345	200	Stop and feed		0.3
				Decided to stop due to the rain	37.5	0.3
						0.3

CONDITIONS:

1. Jet condenser
2. Position of off-gas - pot - Lowest
3. Oil yield - 4.25 gallons (7.8%)
4. Weight of char - 158 lb.
5. Weight of feed - 616.5 lb.
6. Type of blower - Japanese
7. Weight of feed dry basis - 573 lb.
8. Char yield - 27.6%

BUILDING AND ROAD RESEARCH INSTITUTE
PYROLYTIC CONVERTER

DATE: 11/9/78

TEST No. 3

RECORDED BY: KEN YERGAN

CONDITIONS: 8% Moisture Content (Wood Shavings)

TIME	REACTOR	TEMPERATURES °F		COMMENTS	AIR FLOW IN. OF H ₂ O	FEED (LB.)	OUTPUTS (IN GAL.)	
		COND. IN	COND. OUT				CON- DENSER	DEMIS- TER
11:45 a.m.	-	-	-	Start up	0.1	51.5	-	-
12:30 p.m.	220	160	150	Stop and feed	0.1	42.5+	-	-
						41.5+		
						45.0+		
1:00 p.m.	-	155	148	Tap fluid of about 80% water	0.1	42.0	-	-
1:30 p.m.	460	295	168	Stop and feed	0.1	-	0.1	-
1:50 p.m.	700	320	226	Sharp increase of temp. stop & poke	0.1	-	0.066	0.016
2:15 p.m.	870	400	225	Stop again and poke	0.1	-	0.05	0.016
2:30 p.m.	650	325	215	Stop and feed	0.1	-	0.053	-
3:00 p.m.	600	315	205	-	0.1	19.5	0.024	0.004
3:30 p.m.	615	320	215	Tap oil (oil very close to tar)	0.1	-	-	-
4:00 p.m.	615	315	200	-	0.1	-	0.023	0.0079
4:30 p.m.	600	310	200	-	0.1	-	0.02	0.016
5:00 p.m.	600	305	190	Decided to stop for poor reading that is, the low air flow of "0.1" in. of water should not raise the temperature of reactor so high.	0.1	-	0.012	0.0132

Total weight of feed used 262 lb. (39.9% of design spec.)

Total oil collected .451 gals. in 5.25 hrs. of operation

Oil yield 0.22

Weight of feed, dry basis - 241 lb.

BUILDING AND ROAD RESEARCH INSTITUTE
PYROLYTIC CONVERTER

DATE: 9/13/78

TEST No. 4

RECORDED BY: KEN YEBORAH

CONDITIONS: 8% Moisture Content (Wood Shavings)

TIME	REACTOR	TEMPERATURES °F		COMMENTS	AIR FLOW IN. OF H ₂ O	FEED (LB.)	OUTPUTS (IN CAL.)	
		COND. IN	COND. OUT				CON- DENSER	DEMIS- TER
10:10 a.m.	-	-	-	Start up	0.1	-	-	-
10:40 a.m.	-	130	120	Stop and feed	0.1	46.5	-	-
						47.5+		
						38.5+		
11:10 a.m.	-	140	132	Tap fluid (rich in water)	0.1	36.5	-	-
11:40 a.m.	-	147	155	Tap fluid (about 90% H ₂ O)	0.1	-	0.033	-
12:10 p.m.	230	142	155	Increase air flow	0.1	-	0.1	0.01585
12:40 p.m.	200	200	174	Tap fluid (rich in oil)	0.2	-	0.13	0.0238
1:10 p.m.	205	225	185	Fluid still rich in oil	0.2	-	0.066	0.2
1:40 p.m.	205	230	188	Increase air flow	0.2	-	0.04	0.177
2:00 p.m.	300	249	193	Stop and feed	0.3	-	0.024	0.0079
					0.3	38+45+	-	-
2:30 p.m.	520	200	160	Tap fluid (rich in oil)	-	22.0	-	-
3:00 p.m.	510	180	170	-	0.3	-	0.09	0.04
3:15 p.m.	490	198	185	Stop and feed	0.3	-	-	-
3:30 p.m.	510	205	180	-	0.3	45+22	0.123	-
4:00 p.m.	550	235	185	-	0.3	-	0.172	0.0132
4:30 p.m.	555	230	185	Stop and feed	0.3	-	0.053	-
5:00 p.m.	600	240	190	-	0.3	45.5	0.132	0.0053
5:30 p.m.	605	245	190	-	0.3	-	0.16	0.0106
6:00 p.m.	620	260	195	-	0.3	-	0.053	0.0211
					0.3	-	0.177	0.0211

Comments: This time there is not a problem with oil yield. The problem now is how to get the burner working. Plans are on the way. The air flow from the Chicago broiler is too high. It is at the moment acting as a wind tunnel.

Total weight of feed used = 3865 lb. (41.5% of design estimate)

Total oil collected = 1.86 gals. in 7.83 hrs. of operation

Oil yield 5.5%

Weight of feed, dry basis 355.6 lb.

BUILDING AND ROAD RESEARCH INSTITUTE
PYROLYTIC CONVERTER

DATE: 9/19/78

TEST No. 5

RECORDED BY: KEN YERGAN

CONDITIONS: 8% Moisture Content (Wood Shavings)

TIME	REACTOR	TEMPERATURES °F		COMMENTS	AIR FLOW IN. OF H ₂ O	FEED (LB.)	OUTPUTS (IN GAL.)	
		COND. IN	COND. OUT				CON- DENSER	DEMIS- TER
11:00 a.m.	-	-	-	Start with 47 lbs.	0.1	47	-	-
11:30 a.m.	-	145	134	Stop and feed	0.1	48	-	-
12:00 p.m.	-	145	140	Increase air flow	0.2	-	0.0264	0.0198
12:15 p.m.	-	140	140	Stop and feed	0.2	46.5	-	-
12:30 p.m.	-	150	148	-	0.2	-	0.0634	0.0476
12:45 p.m.	230	155	150	Stop and feed	0.2	-	-	-
1:00 p.m.	205	156	151	Increase air flow	0.2	41.5	-	-
1:30 p.m.	210	175	164	-	0.3	-	0.0872	0.111
2:00 p.m.	400	185	170	-	0.3	-	0.0449	0.108
2:15 p.m.	315	185	170	Stop, feed and increase air flow	0.3	-	-	-
2:30 p.m.	230	210	184	-	0.4	54	0.239	0.270
2:45 p.m.	230	210	188	-	0.4	-	-	-
3:00 p.m.	300	220	190	Stop and feed	0.4	-	0.0476	0.0925
3:30 p.m.	350	220	180	-	0.4	45	0.0476	0.0555
3:45 p.m.	300	225	180	Stop and feed	0.4	-	0.0555	0.0687
4:00 p.m.	290	190	174	-	0.4	49	-	-
4:15 p.m.	300	190	170	Stop and feed	0.4	-	0.0317	0.1585
4:30 p.m.	295	170	162	-	0.4	48	-	-
5:00 p.m.	290	190	174	Feed	0.4	-	0.0845	-
5:30 p.m.	290	190	180	-	0.4	47	-	-
6:00 p.m.	350	220	190	-	0.4	-	0.317	-
6:30 p.m.	300	210	184	Feed	0.4	-	-	-
7:00 p.m.	230	185	170	-	0.4	48.5	0.211	0.0148
7:30 p.m.	230	175	164	-	0.4	-	0.244	0.0159
					0.4	-	0.231	0.0330

Total weight of feed used 474.5 lb. (44.7 of design estimate)
 Total oil collected 3.74 gals. in 8.5 hrs. of operation
 Weight of feed, dry basis 436.5 lb.
 Oil yield 9.0%

BUILDING AND ROAD RESE/
PYROLYTIC CONVERTER

DATE: 10/12/78

TEST No. 8

RECORDED BY: KEN YRBOAH AND F. J. HALVAR

CONDITIONS: 7% Moisture Content (Wood Shavings)

TIME	REACTOR	TEMPERATURES °F		COMMENTS	AIR FLOW IN. OF H ₂ O	FEED (LB.)	OUTPUTS (IN GAL.)	
		COND. IN	COND. OUT				CON- DENSER	DEMIS- TER
8:30 a.m.	-	-	-	Start up	-	-	-	-
9:00 a.m.	440	210	140	Stop and feed	0.1	37.0	-	-
9:30 a.m.	500	230	158	-	0.1	35.5+38+39	0.0634	0.0396
10:00 a.m.	570	240	162	Increased air flow	0.1	-	0.026	0.0132
10:30 a.m.	550	310	190	-	0.2	-	0.0596	0.0502
11:35 a.m.	550	310	190	Stop and feed	0.2	-	0.074	0.01585
11:00 a.m.	600	355	185	-	0.2	34+36.25	-	-
11:30 a.m.	450	275	165	Increased air flow feed	0.2	-	0.0925	0.0132
12:00 p.m.	535	320	182	Unable to maintain 0.3 now down to 0.2	0.3	36.75	0.0793	0.053
12:30 a.m.	560	325	177	-	0.2 max	-	0.152	0.074
1:00 p.m.	520	310	180	-	0.2 max	-	0.0343	0.026
1:30 p.m.	530	300	170	Stop and feed	0.2 max	-	0.0634	0.0423
2:00 p.m.	520	225	160	Not happy about gas. Stop and check filter	0.2 max	34+36.5	0.0634	0.058
2:10 p.m.	-	-	-	Crank again: feed	-	-	0.053	0.0793
2:30 p.m.	770	300	180	-	0.1 max	31.5	-	-
3:00 p.m.	690	250	160	-	0.15	-	0.106	0.116
3:30 p.m.	625	230	160	-	0.15	-	0.026	0.0326
4:00 p.m.	480	225	161	-	0.2 max	-	0.026	0.119
4:30 p.m.	510	270	160	-	0.15 max	-	0.0793	0.1057
							.145	0.0845

One gallon of oil plus, 55 lb. of char. decided to stop for poor condenser off-gas temperature.

Total weight of feed used	358.5 lb. (35.85% of design estimate)
Total oil collected	1.9 gals. in 8 hrs. of operation
Weight of feed, dry basis	333.4 lb.
Oil yield	3.12
Char yield	16.5%

BUILDING AND ROAD RESEARCH INSTITUTE
PYROLYTIC CONVERTER

DATE: 10/17/78

TEST No. 9

RECORDED BY: KEN YERGAN AND F. J. HALVAR

CONDITIONS: 7% Moisture Content (Wood Shavings)

TIME	REACTOR	TEMPERATURES °F		COMMENTS	AIR FLOW IN. OF H ₂ O	FEED (LB.)	OUTPUTS (IN GAL.)	
		COND. IN	COND. OUT				CON- DENSER	DEMIS- TER
9:30 a.m.	-	-	-	Start Up				
10:00 a.m.	270	175	140	Stop and feed	0.4	33.5	-	-
10:30	300	225	160	Stop and feed	0.4	32.5+32.5	0.165	0.053
11:00 a.m.	210	210	160	Max air flow but metre reads .38	0.4	33.0	0.053	0.0053
11:10 a.m.	210	225	170	After tempering with blower, metre reading increases	0.38 max	-	0.037	0.0106
11:30 a.m.	400	225	168	Feed	0.43 max	-	-	-
12:00 p.m.	320	260	182	Feed	0.40 max	30.5	0.045	0.0053
12:30 p.m.	520	250	178	Feed	0.43	29.0	0.111	0.1242
1:00 p.m.	570	227	169	Feed	0.43	31.5	0.0502	0.058
1:30 p.m.	550	230	169	Feed	0.40 max	-	0.0845	0.045
2:00 p.m.	470	225	162	Feed	0.43	31.5	0.0423	0.0423
2:30 p.m.	310	225	164	Feed (At 2.15, took some char out)	0.43	-	0.0343	0.0555
3:00 p.m.	310	230	162	Feed	0.38 max	32+33.0	0.0476	0.0476
3:30 p.m.	310	200	160	Feed (Lower Air Flow to .2)	0.38 max	-	0.0713	0.119
4:00 p.m.	380	200	162	Feed	0.33 max	33.0	0.0581	0.111
4:30 p.m.	315	290	156	Stop operation for low condenser off-gas temp.	0.2	-	0.0713	0.100
					0.2	-	0.053	0.0845

Total weight of feed used 383.5 lb. (43.8% of design estimate)
 Total oil collected 1.75 gals. in 7 hrs. of operation
 Weight of feed, dry basis 356.7 lb.
 Oil yield 5.2%

BUILDING AND ROAD RESEARCH INSTITUTE
PYROLYTIC CONVERTER

DATE: 10/23/78

TEST No. 10

RECORDED BY: KEM YEROAH AND P. J. MALVAR

CONDITIONS: 7% Moisture Content (Wood Shavings)

TIME	REACTOR	TEMPERATURES °F		COMMENTS	AIR FLOW IN. OF H ₂ O	FEED (LB.)	OUTPUTS (IN GAL.)	
		COND. IN	COND. OUT				CON- DENSER	DENIS- TER
9:00 a.m.	100	60	54	Start up and feed				
9:30 a.m.	325	275	160	Feed added	0.3	40.25	-	-
10:00 a.m.	200	225	162	Feed added	0.3	40.5	.114	.033
10:15 a.m.	560	350	220	Stop and feed and decreased flow	0.3	42.5	.114	.033
10:30 a.m.	270	254	178	Increased air flow	0.2	39.5	-	-
10:45 a.m.	470	280	184	Feed	0.3	-	.185	.095
11:00 a.m.	420	310	210	Feed	0.3	39.5	-	-
11:20 a.m.	640	300	185	Feed	0.2	39.0	.243	.045
11:30 a.m.	365	310	192	Remove Char	0.2	39.5	-	-
12:00 p.m.	400	240	168	Add feed	0.2	38.75	.198	.011
					0.3	38.75		
12:30 p.m.	430	270	180	Air flow at maximum		+35.75	.053	-
12:45 p.m.	590	235	170	Lower Air Flow to 0.2 add feed	0.25	-	.275	.053
1:00 p.m.	420	240	160	Airflow open to maximum	.2	33.25	.116	.069
1:30 p.m.	460	210	160	Feed (lower and press to .1 at 135 Reactor temp. up to 700)	0.23		.132	.048
					0.2	42.5		
2:00 p.m.	460	270	178			+33.25	.344	.449
2:15 p.m.	520	225	180	Feed added	0.13		-	-
					0.09 max	40	.246	.003
					0.08 max	37.25	.106	.034
2:30 p.m.	210	265	174			+23		
3:00 p.m.	510	250	160	Feed added				
3:30 p.m.	690	325	171	Feed added	0.14 max	34	.344	.077
					0.12 max	36	.177	.225

BUILDING AND ROAD RESEARCH INSTITUTE
 PYROLYTIC CONVERTER
 (Continued)

DATE: 10/23/78

TEST No. 10

RECORDED BY: KEN YEBOAH AND F. J. MALVAR

CONDITIONS: 7% Moisture Content (Wood Shavings)

TIME	REACTOR	TEMPERATURES °F		COMMENTS	AIR FLOW IN. OF H ₂ O	FEED (LB.)	OUTPUTS (IN GAL.)	
		COND. IN	COND. OUT				CON- DENSER	DEMIS- TAR
4:00 p.m.	450	265	162	Feed added				
4:15 p.m.	450	265	162	Feed added	0.16 max	37.25	-	-
4:30 p.m.	615	280	170	Feed added	0.16 max	41.0	.159	.003
5:00 p.m.	480	270	168		0.16 max	-	.074	-
5:30 p.m.	500	270	158	Stopped because of rains	0.07 max	37.25	-	-
Total weight of feed used		788.5 lb. (86.4% of design estimate)						
Total oil collected		4.058 gals. in 7.30 hrs. of operation						
Weight of feed, dry basis		356.7 lb.						
Oil yield		5.2%						

-96-

107

BUILDING AND ROAD RESEARCH INSTITUTE
PYROLYTIC CONVERTER

DATE: 10/25/78

TEST No. 11

RECORDED BY: KEN YERGAN AND F. J. MALVAR

CONDITIONS: 7% Moisture Content (Wood Shavings)

TIME	REACTOR	TEMPERATURES °F		COMMENTS	AIR FLOW IN. OF H ₂ O	FEED (LB.)	OUTPUTS (IN GAL.)	
		COND. IN	COND. OUT				CON- DENSER	DEMIS- TER
9:15 a.m.	-	-	-	Start up feed				
9:30 a.m.	N/R	160	120		.4	41.75	-	-
9:45 a.m.	200	168	126	Feed added	.4		0.0185	0.021
10:00 a.m.	N/R	160	134	Feed added	.4	46+42.75	-	-
10:30 a.m.	610	205	162	Feed added	.4	41.5	0.1717	0.045
11:00 a.m.	500	260	170	Feed added	.2	42.5	0.6473	0.16
11:20 a.m.	820	180	156	Feed added	.3	40	0.7398	0.132
11:30 a.m.	580	200	163	Feed added	.4	44+37.5	-	-
12:00 p.m.	810	225	170	Feed added	.3	45.5	0.476	0.106
12:30 p.m.	930	350	240	Feed added	.35	43.5	0.415	0.108
12:45 p.m.	900	225	180	Feed added	.35	43.5	0.7	0.119
1:00 p.m.	450	210	170		0.2	43.5+43.5	-	-
1:15 p.m.	440	190	162	Feed added	6.2	-	0.164	0.045
1:30 p.m.	526	200	164	Feed added	0.25	46	-	-
2:00 p.m.	630	245	176	Feed added	0.3	39.75	0.21	0.095
2:30 p.m.	1000	220	174	Feed added (Ran out of feed)	0.23	44.25	0.4	0.161
3:00 p.m.	910	320	190	No more feed left	0.33	29.75	0.39	0.108
3:30 p.m.	870	275	158		0.2	-	0.83	0.145
					.15	--	0.1876	0.026

Total weight of feed used
Total oil collected
Weight of feed, dry basis
Oil yield

715.75 lb. (91.6% of design estimate)
6.69 gals. in 6.25 hrs. of operation
665.6 lb.
10.6%

BUILDING AND ROAD RESEARCH INSTITUTE
PYROLYTIC CONVERTER

DATE: 11/3/78

TEST No. 12

RECORDED BY: KEN YEBGAN

CONDITIONS: 8% Moisture Content (Wood Shavings)

TIME	REACTOR	TEMPERATURES °F		COMMENTS	AIR FLOW IN. OF N ₂ O	FEED (LB.)	OUTPUTS (IN GAL.)	
		COND. IN	COND. OUT				CON- DENSER	DEMIS- TER
9:00 a.m.	-	-	-	Start up	-	-	-	-
9:15 a.m.	970	215	164	Feed	0.4	63.75	-	-
9:30 a.m.	-	-	-	Feed	0.3	37.5	-	-
10:00 a.m.	870	360	270	Feed	0.3	41.5	0.713	0.2246
					0.3	43.75*	0.423	0.119
10:10 a.m.	870	200	160	Stopped and check filter	-	39.5	-	-
10:30 a.m.	970	200	160		-	-	-	-
11:00 a.m.	950	30	232	Stop and feed	-	-	0.16	0.1
11:10 a.m.	1000	253	130	Stop and Feed	0.3	36.0	-	0.16
11:15 a.m.				Stopped because of accident	-	-	0.46	-

Total weight of feed used 262 lb. (93.2% of design estimate)
 Total oil collected 2.36 gals. in 2.25 hrs. of operation
 Weight of feed, dry basis 241 lb.
 Oil Yield 10.3%

BUILDING AND ROAD RESEARCH INSTITUTE
PYROLYTIC CONVERTER

DATE: 11/27/78

TEST No. 13

RECORDED BY: KEN YERGAN

CONDITIONS: 7% Moisture Content (Wood Shavings)

TIME	REACTOR	TEMPERATURES °F		COMMENTS	AIR FLOW IN. OF H ₂ O	FEED (LB.)	OUTPUTS (IN GAL.)	
		COND. IN	COND. OUT				CON- DENSER	DENS- TER
10:30 a.m.				Start up with three bags	0.3	127.0		
11:00 a.m.	N/R	160	142	Stop and Feed with two bags	0.3	80.25	0.0449	0.0423
11:30 a.m.	240	180	152	Stop and feed	0.3	46.0	0.127	0.0951
12:00 p.m.	500	205	174	Stop, feed and increase airflow	0.4	40.0	0.2774	0.132
12:15 p.m.	500	220	180	Stop and feed	0.4	36.5	-	-
12:30 p.m.	700	225	182	Stop and feed with two bags	0.4	82.0	0.0343	0.119
1:00 p.m.	1000	245	195	Decrease air flow	0.3	-	0.6605	0.1585
1:30 p.m.	900	160	190	Stop and feed	0.3	43.5	0.0211	0.026
2:00 p.m.	1000	205	171	Increase airflow	0.4	-	0.2378	0.0925
2:15 p.m.	950	250	195	Stop and feed	0.4	43.0	-	-
2:30 p.m.	900	275	214	Decrease air flow	0.3	-	0.37	0.1057
2:45 p.m.	800	270	200	Stop and feed	0.3	37.25	0.2114	-
3:00 p.m.	820	250	190	Stop and feed	0.3	40.5	0.161	0.0449
3:15 p.m.	1000	255	180	Stopped because of short of dry feed	0.3	-	0.238	0.1849

Total weight of feed used
Total oil collected
Weight of feed, dry basis
Oil yield

576 lb. (97% of design estimate)
3.38 gals. in 4.75 hrs. of operation
535.7 lb.
6.6%

BUILDING AND ROAD RESEARCH INSTITUTE
PYROLYTIC CONVERTER

DATE: 12/6-7/78

TEST No. 14

RECORDED BY: KEN YEDDAH

CONDITIONS: 7% Moisture Content (Wood Shavings)

TIME	REACTOR	TEMPERATURE °F		COMMENTS	AIR FLOW IN. OF H ₂ O	FEED (LB.)	OUTPUTS (IN GAL.)	
		COND. IN	COND. OUT				CON- DENSER	DEHIS- TER
10:30 a.m.	-	-	-	Start up				
10:35 a.m.	900	165	150	Stop and feed	0.3	99.75	-	-
11:00 a.m.	1260	170	154		0.3	82.00	0.0661	0.0528
11:30 a.m.	1260	175	160	Stop and feed	0.3	-	-	-
12:00 p.m.	1250	170	157	Increase air flow	0.3	31.75	0.222	0.132
12:10 p.m.	1250	170	157	Stop and feed	0.4	-	0.0132	0.0581
12:30 p.m.	1250	175	154	Stop and feed	0.4	24.5	-	-
12:40 a.m.	1250	170	160	Stop and feed	0.4	37.0	-	-
1:00 p.m.	1250	165	154	Stopped for some time to look into the reason why temps have fallen so low	0.4	39.75	0.528	0.4227
2:20 p.m.	800	165	155	Crank again	0.4	38.75	-	-
2:35 p.m.	800	305	200	Stop to feed	0.4	-	0.7926	0.2114
2:45 p.m.	855	395	206	Decrease air flow	0.4	25.5	-	-
3:00 p.m.	830	350	190	Stop and feed	0.3	-	0.2246	0.026
3:30 p.m.	800	345	185	Stop and feed	0.3	33.5	-	-
4:00 p.m.	800	340	180	Stop and feed for tomorrow	0.3	33.0	0.3435	0.1321
						38.5	0.238	0.1057
7/12/78								
8:30 a.m.	-	-	-	Cranked again	0.4	-	-	-
9:20 a.m.	500	290	160	Stop and feed	0.4	34.5	0.026	0.0528

BUILDING AND ROAD RESEARCH INSTITUTE
 PYROLYTIC CONVERTER
 (Continued)

DATE: 12/6-7/78

TEST No. 14

RECORDED BY: KEN YESOAN

CONDITIONS: 7% Moisture Content (Wood Shavings)

TIME	REACTOR	TEMPERATURES °F		COMMENTS	AIR FLOW IC. OF H ₂ O	FEED (LB.)	OUTPUTS (IN GAL.)	
		COND. IN	COND. OUT				CON- DENSER	DEMIS- TER
10:10 a.m.	500	355	220	Stop and feed				
11:00 a.m.	550	330	200	Stop and feed	0.4	37.0	0.0925	0.0793
11:30 p.m.	600	250	150	Stop and feed	0.4	37.5	0.1321	0.0793
12:00 p.m.	650	280	200	Stop and feed	0.4	37.5	-	-
1:00 p.m.	750	285	200	Stop and feed	0.4	31.5	0.119	0.0528
1:45 p.m.	800	280	190	Stop and feed	0.4	35.5	0.185	0.1321
2:30 p.m.	850	290	220	Stop and feed	0.4	29.5	0.1585	0.026
3:00 p.m.	800	290	210	Stop and feed	0.4	35.0	0.2246	0.1321
3:35 p.m.	800	295	200	Stop and feed	0.4	35.0	0.1585	0.238
4:00 p.m.	800	300	210	Shut down	0.4	35.5	0.1057	0.0581

Total weight of feed used 832.5 lb. (69.44% of design estimate)
 Total oil collected 5.87 gals. in 12 hrs. of operation
 Weight of feed, dry basis 774.2 lb.
 Oil yield 8.0%

BUILDING AND ROAD RESEARCH INSTITUTE
PYROLYTIC CONVERTER

DATE: 12/19/78

TEST No. 17

RECORDED BY: KEN YEBOAH

CONDITIONS: 6% Moisture Content (Wood Shavings)

TIME	REACTOR	TEMPERATURES °F		COMMENTS	AIR FLOW IN. OF H ₂ O	FEED (L.S.)	OUTPUTS (IN GAL.)	
		COND. IN	COND. OUT				CON- DENSER	DEMIS- TER
9:30 a.m.	-	-	-	Start up	0.4	111.0	-	-
10:00 a.m.	680	245	200	Stop and feed	0.4	62.75	0.3699	0.0528
10:20 a.m.	690	250	200	Stop and feed	0.4	69.0	-	-
10:30 a.m.	700	300	200	-	0.4	-	0.753	0.0528
10:50 a.m.	700	290	190	Stop and feed	0.4	60.5	-	-
11:00 a.m.	710	275	184	-	0.4	-	0.2246	0.0396
11:30 a.m.	710	350	210	Stop and feed	0.4	75	0.41	-
12:00 p.m.	710	355	210	-	0.4	-	0.185	0.0122
12:20 p.m.	N/R	300	200	Stop and feed	0.4	38.5	-	-
12:30 p.m.	N/R	280	180	-	0.4	-	0.14	0.0053
1:00 p.m.	N/R	350	210	Stop and feed	0.4	-	0.211	0.0026
1:30 p.m.	N/R	350	200	Stop and feed	0.4	41.0	0.119	0.0
2:15 p.m.	N/R	325	180	-	0.4	66.5	0.238	0.0661
2:45 p.m.	N/R	300	170	Stop and feed	0.4	32.25	0.1585	0.0661
3:25 p.m.	N/R	200	150	-	0.4	-	0.1057	0.0132
4:00 p.m.	N/R	200	152	Stop and feed	0.4	30.75	0.0793	0.1585
4:30 p.m.	N/R	225	160	-	0.4	-	0.0793	0.0661
5:00 p.m.	N/R	225	160	Stop and feed	0.4	66.50	0.1982	0.0528
5:30 p.m.	N/R	310	204	-	0.4	-	-	-

BUILDING AND ROAD RESEARCH INSTITUTE
 PYROLYTIC CONVERTER
 (Continued)

DATE: 12/19/78

TEST No. 17

RECORDED BY: KEM YEBOAH

CONDITIONS: 7% Moisture Content (Wood Shavings)

TIME	REACTOR	TEMPERATURES °F		COMMENTS	AIR FLOW IN. OF H ₂ O	FEED (LB.)	OUTPUTS (IN GAL.)	
		COND. IN	COND. OUT				CON- DENSER	DEMIS- TER
6:00 p.m.	N/R	250	180	Stop and feed	0.4	34.75	0.0396	0.1057
6:30 p.m.	N/R	275	188		0.4	-	0.0793	0.0634
7:00 p.m.	N/R	280	168		0.4	-	0.0793	-
7:15 p.m.	N/R	300	170	Stop and feed	0.4	37.0	-	-
7:45 p.m.	N/R	325	284	Shut down	0.4	-	0.0425	0.0053
Total weight of feed used		725.5 lb. (56.6% of design estimate)						
Total oil collected		4.32 gals. in 10.25 hrs. of operation						
Weight of feed, dry basis		682 lb.						
Oil yield		6.7%						

BUILDING AND ROAD RESEARCH INSTITUTE
PYROLYTIC CONVERTER

DATE: 1/8/79

TEST No. 18

RECORDED BY: KEN YKBOAH

CONDITIONS: 6% Moisture Content (Wood Shavings)

TIME	REACTOR	TEMPERATURES °F		COMMENTS	AIR FLOW IN. OF H ₂ O	FEED (LB.)	OUTPUTS (IN GAL.)	
		COND. IN	COND. OUT				CON- DENSER	DEMIS- TER
10:00 a.m.	-	-	-	Start up				
10:30 a.m.	700	200	163	Stop and feed	0.5	120.25	-	-
11:00 a.m.	790	260	180	Stop and feed	0.5	52.25	0.201	0.100
11:30 a.m.	1000+	400	220	Stop and feed	0.5	71.75	0.855	0.137
11:45 a.m.	1000+	350	220	Stop and feed	0.5	-	0.277	0.246
12:00 p.m.	1000+	310	204	Reduce air flow due to high temp.	0.5	70.5	-	-
12:30 p.m.	1000+	240	164		0.3	-	0.211	0.0264
12:40 p.m.	1000+	250	170	Stop and feed	0.3	-	0.264	0.0793
1:00 p.m.	1000+	290	188	Stop and feed	0.3	66.75	-	-
1:30 p.m.	1000+	430	214	Stop and feed	0.3	-	0.238	0.0326
2:00 p.m.	1000+	265	184	Shut down	0.3	52.75	0.264	0.0026
						-	0.240	0.0026

Total weight of feed used 434.25 lb. (86.8% of design estimate)
 Total oil collected 3.18 gals. in 4 hrs. of operation
 Weight of feed, dry basis 408.2 lb.
 Oil yield 8.2%

BUILDING AND ROAD RESEARCH INSTITUTE
PYROLYTIC CONVERTER

DATE: 2/8/79

TEST No. 20

RECORDED BY: KEN YEBOAH

CONDITIONS: 6% Moisture Content (Wood Shavings)

TIME	REACTOR	TEMPERATURES °F		COMMENTS	AIR FLOW IN. OF 2.0	FEED (LB.)	OUTPUTS (IN GAL.)	
		COND. IN	COND. OUT				CON- DENSER	DEMIS- TER
9:50 a.m.	-	-	-	Start up	0.5	-	-	-
10:05 a.m.	650	155	140	Stopped to check leakages at the top	-	136.5	-	-
10:15 a.m.	-	155	140	Cranked again	0.5	-	-	-
10:45 a.m.	690	170	160	Stop and feed	0.5	-	-	-
11:15 a.m.	1000+	225	180	Feed & move char handle 20x	0.5	70.0	0.753	0.1162
11:45 a.m.	1000+	230	184	Feed & move char handle 20x	0.5	34.0	0.925	0.119
12:00 p.m.	1000+	250	186	Stop and feed	0.5	-	-	-
12:15 p.m.	1000+	300	210	Move char handle 20x	0.5	63.5	0.7926	.0026
12:30 p.m.	1000+	275	130	Move char handle 20x	0.5	-	-	-
12:40 p.m.	1000+	275	190	Stop and feed	0.5	-	0.330	0.0264
12:45 p.m.	1000+	275	190	Move char handle 20x	0.5	63.5	-	-
1:00 p.m.	1000+	275	200	Move 20x and feed	0.5	-	-	-
1:30 p.m.	1000+	210	190	-	0.5	31.5	0.528	0.0528
1:45 p.m.	1000+	210	190	-	0.5	-	0.198	0.0264
2:00 p.m.	1000+	225	181	Stop and feed plus 20x	0.5	-	-	-
2:30 p.m.	1000+	250	196	-	0.5	62.5	0.227	-
2:45 p.m.	1000+	250	196	Stop and feed plus 20x	0.5	-	0.185	-
3:30 p.m.	1000+	350	222	-	0.5	60.0	0.317	0.0026
4:00 p.m.	1000+	235	183	Shut down	0.5	-	0.357	0.0396
					0.5	-	0.264	0.1321

Total weight of feed used
Total oil collected
Weight of feed, dry basis
Oil yield

521.5 lb. (67.6% of design estimate)
5.63 gals. in 6.17 hrs. of operation
490.2 lb.
12.1%

BUILDING AND ROAD RESEARCH INSTITUTE
PYROLYTIC CONVERTER

DATE: 2/14/79

TEST No. 21

RECORDED BY: KEN YEBOAH

CONDITIONS: 6% Moisture Content (Wood Shavings)

TIME	REACTOR	TEMPERATURES °F		COMMENTS	AIR FLOW IN. OF H ₂ O	FEED (LB.)	OUTPUTS (IN GAL.)	
		COND. IN	COND. OUT				CON- DENSER	DENIS- TER
9:40 a.m.	-	-	-	Start up	0.5	113.5	-	-
10:10 a.m.	600	230	190	Tap, feed and move handle 30x	0.5	89.5	1.030	0.158
10:40 a.m.	590	230	200	Move char handle 30x and feed	0.5	67.25	0.727	0.0793
10:55 a.m.	540	210	176	Move char handle 30x	0.5	-	-	-
11:11 a.m.	560	230	180	30x plus feeding	0.5	61.0	0.793	0.0793
11:25 a.m.	555	225	190	30x	0.5	-	-	-
11:40 a.m.	570	250	200	30x	0.5	-	-	-
11:50 a.m.	570	250	200	Feeding	0.5	63.25	0.755	0.0925
12:15 p.m.	540	265	210	30x plus feeding	0.5	59.75	0.605	0.0793
12:30 p.m.	520	250	204	30x stopped for 15 mins. (Capstan arm)	0.5	32.5	-	-
12:45 p.m.	560	250	200	30x	0.5	-	0.449	0.0740
1:00 p.m.	520	285	220	Moved char handle 30x	0.5	-	-	-
1:15 p.m.	570	250	180	30x plus feeding	0.5	65.5	0.264	0.0396
1:45 p.m.	560	250	180	Char barrel row full so stopped for 30 minutes for off loading	-	-	0.6077	0.0898
2:15 p.m.	510	180	162	30x plus feeding	0.5	28.5	-	-
2:30 p.m.	470	230	180	30x	0.5	-	-	-
2:45 p.m.	510	235	190	30x plus feeding	0.5	66.0	0.766	0.1136
3:00 p.m.	510	235	190	30x, tap and shut down	0.5	-	0.5627	0.1057

Total weight of feed used 646.75 lb. (97.1% of design estimate)
 Total oil collected 7.47 gals. in 5.33 hrs. of operation
 Weight of feed, dry basis 607.9 lb.
 Oil yield 12.9%

BUILDING AND ROAD RESEARCH INSTITUTE
PYROLYTIC CONVERTER

DATE: 2/16/79

TEST No. 22

RECORDED BY: KEN YERGAN

CONDITIONS: 8% Moisture Content (Wood Shavings)

TIME	REACTOR	TEMPERATURES °F		COMMENTS	AIR FLOW IN. OF H ₂ O	FEED (LB.)	OUTPUTS (IN GAL.)	
		COND. IN	COND. OUT				CON- DENSER	DEMIS- TER
9:40 a.m.	-	-	-	Start up	0.5	104.0	-	-
9:55 a.m.	620	198	162	Moved grate handle 30x	0.5	-	-	-
10:10 a.m.	798	256	180	-	0.5	-	-	-
10:30 a.m.	800	260	184	Moved grate handle 30x plus feeding	0.5	100.5	1.075	0.0793
10:40 a.m.	980	215	180	30x	0.5	-	-	-
10:50 a.m.	1000+	215	180	Stop and feed	0.5	-	0.571	0.0793
11:10 a.m.	1000+	265	186	Moved grate handle 30x	0.5	68.75	-	-
11:35 a.m.	1000+	260	176	Stop and feed plus 30x	0.5	-	0.708	0.0978
12:05 p.m.	1000+	280	184	Stop and feed plus 30x	0.5	67.25	0.515	0.0713
12:20 p.m.	1000+	284	184	Moved grate handle 30x	0.5	35.5	0.317	0.0528
12:30 p.m.	1000+	284	184	Shut down	0.5	-	-	-
					0.5	-	0.489	0.0793
Total weight of feed used		376.16 lb. (106.2% of design estimate)						
Total oil collected		4.085 gals. in 2.83 hrs. of operation						
Weight of feed, dry basis		346 lb.						
Oil yield		12.4%						

BUILDING AND ROAD RESEARCH INSTITUTE
PYROLYTIC CONVERTER

DATE: 3/1/79

TEST No. 23

RECORDED BY: KEN YERGAN

CONDITIONS: 7% Moisture Content (Wood Shavings)

TIME	REACTOR	TEMPERATURES °F		COMMENTS	AIR FLOW IN. OF H ₂ O	FEED (LB.)	OUTPUTS (IN GAL.)	
		COND. IN	COND. OUT				CON- DENSER	DEMIS- TER
10:00 a.m.	-	-	-	Start up	0.5	101.0	-	-
10:20 a.m.	400	250	160	Stop and feed	0.5	68.0	-	-
10:30 a.m.	350	220	180	Moved char handle 50x	0.5	-	0.476	0.106
11:00 a.m.	420	260	190	Feeding	0.5	66.5	0.592	0.053
11:10 a.m.	420	260	190	Stopped to check flow of char	0.5	-	-	-
11:30 a.m.	500	300	224	Feeding and 50x movement	0.5	67.5	0.502	0.0396
12:00 p.m.	500	310	220	Moved char handle 50x	0.5	-	0.396	0.0264
12:15 p.m.	650	225	190	Feeding and dropping of char	0.5	67.5	-	-
12:30 p.m.	630	250	200	Stopped for feeding and dropping of char barrel	0.5	63.5	0.626	0.0661
1:45 p.m.	400	255	160	Cranked again	0.5	-	-	-
2:15 p.m.	420	262	185	Shut down because of excess leakage at the top	-	-	0.579	0.1242

Total weight of feed used 434 lb. (81.17% of design estimate)
Total oil collected 3.59 gals. in 4.25 hrs. of operation
Weight of feed, dry basis 403.6 lb.
Oil yield 9.3%

BUILDING AND ROAD RESEARCH INSTITUTE
PYROLYTIC CONVERTER

DATE: 3/9/79

TEST No. 24

RECORDED BY: KEN YEDDAH

CONDITIONS: 6% Moisture Content (Wood Shavings)

TIME	REACTOR	TEMPERATURES °F		COMMENTS	AIR FLOW IN. OF H ₂ O	YIELD (L.B.)	OUTPUTS (IN GAL.)	
		COND. IN	COND. OUT				CON- DENSER	DEMIS- TER
9:30 a.m.	N/R	-	-	Start up	0.5	99.5	-	-
10:00 a.m.	N/R	210	190	Stop and feed	0.5	66.0	0.476	0.151
10:30 a.m.	N/R	290	225	Moved char handle 50x	0.5	-	0.660	0.0581
10:45 a.m.	N/R	294	225	Stop and feed	0.5	90.0	-	-
11:00 a.m.	N/R	334	240	Moved char handle 50x	0.5	-	0.528	0.0978
11:30 a.m.	N/R	250	208	Stop and feed put 50x	0.5	109.5	0.523	0.124
12:00 p.m.	N/R	250	210	Measured yield at Scavenger fan = 1200	0.5	-	0.396	0.219
12:45 p.m.	N/R	256	212	Stop and feed plus 50x	0.5	95.25	-	-
1:00 p.m.	N/R	240	210	Stop and feed plus 50x	0.5	33.75	0.383	0.2457
1:30 p.m.	N/R	350	184	Shut down	0.5	-	0.248	0.132

Total weight of feed used 494.16 lb. (98.8% of design estimate)
 Total oil collected 4.24 gals. in 4 hrs. of operation
 Weight of feed, dry basis 464.5 lb.
 Oil yield 9.6%

BUILDING AND ROAD RESEARCH INSTITUTE
PYROLYTIC CONVERTER

DATE: 8/22/80

CONVERTOR NO. 1

FINAL TEST RECORDED BY: MALVAR/KOVAC

CONDITIONS: Feed 10% Moisture Content

TIME	TEMPERATURES °F			COMMENTS	AIR FLOW IN. OF H ₂ O	FEED (LB.)	OUTPUTS (IN GAL.)	
	REACTOR (measured in 4-quads.)	COND. IN	COND. OUT				CON- DENSER	DEMIS- TER
8:45 a.m.	-	-	-	Start up light with kerosene	-	-	-	-
9:00 a.m.	-	-	-	Load reactor with sawdust	0.5	126.0	-	-
9:05 a.m.	-	-	-	Close center air valve and valve below the offgas filter	0.8	-	-	-
9:35 a.m.	820-240 700-1210	240	220	Reactor pressure 9 oz.	0.53	-	0.19	0.04
9:50 a.m.	460-180 920-900	200	160		0.45	-	-	-
10:00 a.m.	-	-	-	Converter pressure = 10 oz.	-	-	0.436	0.99
10:05 a.m.	-	-	-	Shut down to feed. Start up at 10:10	-	84.5	-	-
10:15 a.m.	900-1000 500-960	235	175		0.5	-	-	-
10:30 a.m.	-	-	-		-	-	0.7925	0.449
10:45 a.m.	-	-	-	*Oil collected at manifold	-	-	0.132	0.264*
11:00 a.m.	720-660 700-980	280	205	Demister temp = 200°F	0.42	-	-	-
11:05 a.m.	-	-	-	Shut down to feed. Startup at 11:15	0.5	91.0	0.383	0.535
11:20 a.m.	500-560 420-620	275	185	Demister Temp = 175°F	0.53	-	-	-
11:30 a.m.	-	-	-		-	-	0.3434	0.56

BUILDING AND ROAD RESEARCH INSTITUTE
 PYROLYTIC CONVERTER
 (Continued)

DATE: 8/22/80

CONVERTOR NO. 1

FINAL TEST RECORDED BY: MALVAR/KOVAC

CONDITIONS: Feed 10% Moisture Content

TIME	REACTOR (measured in 4-quads.)	TEMPERATURES °F		COMMENTS	AIR FLOW IN. OF H ₂ O	FEED (LB.)	OUTPUTS (IN GAL.)	
		COND. IN	COND. OUT				CON- DENSER	DEMIS- TER
11:45 a.m.	-	-	-	Shutdown to feed. Start up at 11:55	-	98.5	-	-
11:50 a.m.	460-620 620-620	220	17	Demister temperature = 175°F #1 dryer operatin on burning Off gas -- burner lit *oil collected at manifold	0.48	-	-	0.75
12:10 p.m.	-	-	-		-	-	-	0.127*
12:30 p.m.	820-800 860-720	205	195	Demister temperature = 175°F Convertor pressure = 16 oz.	0.32	-	0.666	0.25
12:45 p.m.	-	-	-		-	-	0.917	0.502

-111-

122

BUILDING AND ROAD RESEARCH INSTITUTE
PYROLYTIC CONVERTER

DATE: 8/27/80

CONVERTOR NO. 2 FINAL TEST

RECORDED BY: MALVAR/KOVAC

CONDITIONS: Feed 10% Moisture Content

TIME	REACTOR (measured in 4-quads.)	TEMPERATURES °F		COMMENTS	AIR FLOW IN. OF H ₂ O	FEED (LB.)	OUTPUTS (IN GAL.)	
		COND. IN	COND. OUT				CON- DENSER	DEMIS- TER
8:55 a.m.	-	-	-	Start up light with kerosene	-	-	-	-
9:08 a.m.	-	-	-	Load reactor with sawdust	-	-	-	-
9:25 a.m.	500-430	170	150		0.5	148.5	-	-
	520-150	-	-		0.5	-	-	-
9:35 a.m.	-	-	-		-	-	-	-
9:56 a.m.	640-600	180	160	Demister outlet 150°F	0.2	-	0.073	-
	760-260	-	-		-	-	-	-
10:00 a.m.	-	-	-	Converter pressure = 0 oz.	-	-	-	-
10:05 a.m.	-	-	-	Shut down to feed. Start at 10:15	-	-	0.159	-
10:15 a.m.	500-860	190	175	Demister Temp. = 150	0.3	93.5	-	-
	520-200	-	-		-	-	-	-
10:30 a.m.	-	-	-	*Oil collected at manifold	-	-	0.296	0.264*
11:00 a.m.	660-860	190	190	Converter pressure = 16 oz.	0.2	-	-	-
	480-600	-	-	Demister temp. = 155°F	-	-	-	-
11:05 a.m.	-	-	-		-	-	0.0792	0.304
11:05 a.m.	-	-	-	*Oil collected at manifold	-	-	-	0.34346
11:10 a.m.	-	-	-	Shut down to feed. Start at 11:5	-	-	-	-
11:20 a.m.	320-420	175	160	Demister temperature = 150°F	0.48	96.5	-	-
	340-240	-	-		-	-	-	-
11:30 a.m.	-	-	-		-	-	0.6762	0.136
11:50 a.m.	880-640	195	175	Demister temperature = 155°F	0.4	86.5	0.127*	0.3328
	480-720	-	-	*oil collected at manifold	-	-	-	-
12:10 p.m.	-	-	-		-	-	0.5	0.217
12:30 a.m.	320-720	290	200	*Oil collected at scavage fan	0.56	-	-	0.264*
	380-1200	-	-	Demister temp. = 170°F	-	-	-	-
12:45 p.m.	-	-	-	Converter pressure = 5 oz.	-	-	0.502	0.339

BUILDING AND ROAD RESEARCH INSTITUTE
PYROLYTIC CONVERTER

DATE: 8/27/80 CONVERTOR NO. 3 FINAL TEST

RECORDED BY: MALVAR/KOVAC

CONDITIONS: Feed 10% Moisture Content

TIME	REACTOR (measured in 4-quads.)	TEMPERATURES °F		COMMENTS	AIR FLOW IN. OF H ₂ O	FEED (LB.)	OUTPUTS (IN GAL.)	
		COND. IN	COND. OUT				CON- DENSER	DEMIS- TER
8:55 a.m.	-	-	-	Start up light with kerosene	-	-	-	-
9:13 a.m.	-	-	-	Load reactor with sawdust	-	-	-	-
9:35 a.m.	-	-	-	No oil	0.5	137.25	-	-
9:40 a.m.	-	-	-	Shutdown - leakage at char barrel seal	0.5	-	-	-
10:52 a.m.	-	-	-	Start up - Leaks repaired	-	-	-	-
11:00 a.m.	480-600 560-560	155	130	*Oil collected at manifold and scavenger fan	0.5	-	-	0.3434
11:05 a.m.	-	-	-	Demister temperature = 150°F	-	-	0.0132	0.0528
11:20 a.m.	780-420 720-440	235	155	Shut down to feed. Start up at 11:30	0.2	66.0	-	-
11:30 a.m.	-	-	-	*Oil collected at manifold	-	-	0.502	-
11:50 a.m.	520-520 480-500	210	185	-	0.58	-	*0.127	0.132
11:55 a.m.	-	-	-	-	-	78.5	-	-
12:10 p.m.	-	-	-	*Oil collected at scavenger fan	-	-	0.666	0.132*
12:30 p.m.	640-700 850-380	240	205	Demister temp. = 185°F	0.49	-	-	-
12:45 p.m.	-	-	-	Convertor pressure 13 oz.	-	-	0.666	0.33

BUILDING AND ROAD RESEARCH INSTITUTE
PYROLYTIC CONVERTER

DATE: 8/27/80

CONVERTOR NO. 4 FINAL TEST

RECORDED BY: MALVAR/KOVAC

CONDITIONS: Feed 10% Moisture Content (Wood Shavings)

TIME	REACTOR (measured in 4-quads.)	TEMPERATURES °F		COMMENTS	AIR FLOW IN. OF H ₂ O	FRED (LB.)	OUTPUTS (IN GAL.)	
		COND. IN	COND. OUT				CON- DENSER	DEMIS- TER
8:55 a.m.	-	-	-	Start up - light with kerosene	-	-	-	-
9:20 a.m.	-	-	-	Load reactor with sawdust	-	-	-	-
9:35 a.m.	-	-	-	-	0.5	46.5	-	-
9:50 a.m.	-	-	-	Shut down to repair leakage	-	-	0.085	-
10:00 a.m.	-	-	-	at char barrel - startup at 10:00	-	-	-	-
10:15 a.m.	620-380	175	145	Converter pressure 0 oz.	-	-	-	-
10:30 a.m.	580-300	-	-	Demister Temp = 140°F	0.4	-	.087	-
10:40 a.m.	-	-	-	*Oil collected at manifold	-	-	-	-
11:00 a.m.	630-480	150	150	Shutdown to feed. Start up at 10:50	-	-	0.2113	0.264*
11:05 a.m.	680-400	-	-	*Oil collected at manifold and	0.5	18.5	-	-
11:20 a.m.	900-770	220	175	scavenger ign	-	-	-	0.3434*
11:30 a.m.	930-600	-	-	-	0.45	-	0.726	0.1783
11:50 a.m.	420-620	180	175	*Oil collected at manifold	-	-	0.70	0.132
12:10 p.m.	980-440	-	-	-	0.25	13	0.127*	0.132
12:30 p.m.	700-760	250	200	Demister temp. = 185°F	-	-	0.5	0.217
12:45 p.m.	870-460	-	-	*Oil collected at scavenger fan	0.55	-	-	0.132*
					-	-	0.5	0.5

RESULTS OF FINAL TEST

	<u>Converto.</u>			
	<u>1</u>	<u>2</u>	<u>3</u>	<u>4</u>
Feed Rate (wet) # hr.	106.8	118.6	125.33	85.57
Feed Rate (dry basis) # hr.	96.12	106.74	112.80	77.01
Total Feed #	400.5	425	282	328.
Oil Yield Overall (dry basis)	21.66%	11.938%	12.246%	14.87%
Oil Production Rate Overall (dry basis)	1.982 gph	1.214 gph	1.31 gph	1.2241 gph
Oil Yield-steady state (1)	23.12%	18.05%	13.173%	18.626%
Oil Production Rate-steady state (1)	2.413 gph	1.699 gph	1.847 gph	2.021 gph
Total Oil Production (Gal.)	7.436	4.349	2.96	4.182

4 Converter System

1435.5#	Total Feed
436.3#- hr.	Feed Rate (wet)
392.67# - hr.	Feed Rate (db)
18.925 gal.	Total Oil Production
13.416	Hours of Operation
1.410 gph	Oil Production Rate - Overall
15.381%	Oil Yield - Overall
2.03954 gph	Oil Production Rate - Steady State
17.337%	Oil Yield - Steady State

(1) Steady State conditions were considered after 1/2 to 1 hour of start-up.

APPENDIX D
Inventory of Spare Parts

Inventory of Spare Parts

1.	Dwyer Magnetic Pressure Gauge Model 2010	6
2.	Ashcroft Industrial Thermometers	5
3.	Magnehelic Max Pressure 15 Psig	3
4.	Dayco Synchro - Cog belt	4
5.	Dayton Motor Starter	1
6.	Heat Conductive Compound	3 tins
7.	Gasoline and Oil Resistant Cable	1 roll
8.	Oil - Tight Selector Switch	4
9.	Stockham Valves & Fittings	7
10.	High Temperature Insulating Kaowool	1
11.	Silicone Rubber Sealant	22
12.	Fusible Alloy Damper Control 280°F	6
13.	Oval Head Carriage Bolt	¼ packet:
14.	Collar (steel)	8
15.	Washers	2 half packets
16.	Screws	2 types
17.	Asbestos Rollboard	1 roll
18.	Rubber gasket	1 roll
19.	Wire mesh (stainless steel)	1 roll
20.	Wire mesh (mild steel, fine)	1 roll
21.	Wire mesh (mild steel, rough)	¼ roll
22.	Small size wire mesh (rough)	1 roll
23.	Brass wells	12
24.	Pulley for windjammer	1
25.	Roller wheel	1
26.	Char probe	1
27.	Clamps for pulley	3
28.	Cable wire	

BELTS

29.	Demco V-Belt	Size 48	9
30.	Demco V-Belt	Size 34	3

31.	Demco V-Belt	Size 19	2
32.	Demco V-Belt	Size 20	2
33.	Demco V-Belt	Size 50	1
34.	Demco V-Belt	Size 49	8
35.	Dayton Motor Control		3
36.	Pulley for Chicago Blowers' Motor		2
37.	Scavenger Dayton Blower		1
38.	Dayton Capacitor Start A.C. Motor H.P. 3/4		1

APPENDIX E
Chronological History of the Project

Chronological History of Project

Jan. 78 - March 78
Construction and Testing of Prototype
- Tatom and Moh

July 78
Continued Testing of Prototype - New Condenser
and Demister Design - Goodrum, Tatom and
Moh

July 78 - Sept. 78
Continued Testing of Prototype - Yeboah

Sept. 78 - Oct. 78
Further Development of Prototype and Operations
Procedures. Improvement of Product Yields
- Malvar

Oct. 78 - April 79
Additional Fabrication, Construction and
Testing of Prototype - Yeboah

May 79
End of Prototype Development. Achievement
of Design Yields. Finalization of Combined
System Design. Begin Construction and
Installation of Four Converter System
- Malvar

May 79 - Sept. 79
Finish Construction of Building Housing
the Four Reactors. Provide Power to Site
At Fumasua. Electrical Work at Plant.
Assembly of System. -- BBRI, TCC

Aug. 79 - Sept. 79
Supervise and Assist in above. Plant
layout. - Malvar and Stone

July 80 - Aug. 80
Finish offgas piping. Debug four reactor
system and Leak Test. Performance Testing
of Combined System. End of Project.
Malvar and Kovac

APPENDIX F
Proposed Pyrolytic Converter Social Soundness

MANAGEMENT AND INVESTMENT CONSULTANTS LTD.

17 Second Crescent, Asylum Down, Accra.

Phone: 29229

Cables: MANCONSULT, ACCRA.

P. O. Box 11950,
Accra-Ghana.

3 July 1980

Mr. J. Cooper
USAID
Accra

Dear Sir:

PYROLYTIC CONVERTER DEMONSTRATION PROJECT (no.698-0135) -
SOCIAL SOUNDNESS ANALYSIS

1. As promised please find enclosed an outline on our suggested approach to the above study. We regret the delay in submitting the preliminary outline. We thought the preliminary laboratory work was needed to help us come out with a suggested approach to the study.
2. We propose that we use the outline, as may be modified by you, as a basis for the initial discussion with the Georgia Tech team so that firm decision may be taken on the need for the laboratory investigation. It is possible that some work might already have been done in other countries.
3. We look forward to discussing the outline with you and the Georgia Tech team.

Yours faithfully,

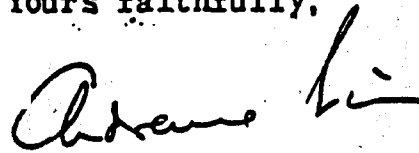

A. Kwame Pianim
Executive Chairman.

cc: Prof. Tackie,
Accra.

DIRECTORS: Kofi Atta Amman, Andrews Kwame Pianim, Edward Pianim (Managing)

Annex Table I
 PYROLYTIC CONVERTER DEMONSTRATION PROJECT
 (Social Soundness Analysis)
 PRELIMINARY COST INDICATION

A. Laboratory Investigation		Foreign Ex- change \$US
1. Expert services:		
a) 1.5 man-months using 3 experts at ¢15,000 per man-month	22,500	--
b) 2 laboratory technicians for one month (2 man-months at ¢8,000 per man-month)	16,000	--
2. Laboratory material (ether, alcohol, chemicals, wick, etc.)	1,500	250.00
3. Equipment:		
a) local heating and lighting appliances ^{1/}	5,000	--
b) fractionating and distillation equip- ment ^{2/} and spares	--	3,500.00
4. TOTAL	45,000	3,750.00

^{1/} 4 hurricane lamps (2 for urban and 2 for rural family test work after laboratory use) at ¢250 each. 1 Alladin lamp at ¢400, 4 village lantern at ¢50 each, 11 kerosene stoves at ¢2000, 2 Priapus stoves at ¢1000 each and 2 coal pots at ¢100 each.

^{2/} Includes Gas Liquid chromatograph, thin layer chromatograph, spectrophotometer, high vacuum distillation apparatus for oil and bomb calorimeter.

B. Social & Economic Evaluation

1. Expert services:

- a) one man-month of expert services at c15,000 per man/month 15,000
- b) 1.5 man-months of field assistant services at c8,000 per man/month 12,000

2. Transportation (4 return trips to Kumasi at c1 per kilometre) 1,440

3. Per diem allowance for field trips for two for 15 days at c200 per day. 6,000

4. Admin. overhead, report writing & printing 5,000

5. TOTAL under (B) c39,440

C.

1. Total Estimated Contract price:

- a) Cedi element 84,440
- b) Foreign exchange element 3,750

2. Made up of:

- a) Consolidated payments (items A1, A3, and total B)
- b) Reimbursable expenses (A2, A4)

c 81,940
6,500 and
3,750

PYROLYTIC CONVERTER DEMONSTRATION PROJECT

(no. 698-0135)

Social Soundness Analysis

1. Given the normal inter-relationship between social, economic and technical aspects of projects, the social soundness analysis called for in the contract must of necessity be expected to extend into the other two areas to be effective.
2. Our analysis was expected to identify and evaluate the social impact of the various applications that the oil and char from the pyrolytic plant might be put to improve the living standards of the rural and urban poor.
3. The source of lighting for the rural inhabitants is by and large kerosene. Although some 70% of the population in Ghana is estimated to live in the rural areas, only some 2% of the rural population have access to electricity. Some 35% of the urban population is estimated as having access to electricity which in Ghana is derived up to some 90% from hydro source. Thus over 90% of rural inhabitants and some 65% of urban dwellers depend on kerosene for lighting.
4. In the light of rising petroleum prices the Government raised the selling price of one gallon of kerosene from 1¢ to \$3.50 in December 1979 in spite of the general recognition of the significant of kerosene as a source of fuel in the household budget of the average worker. For the urban worker kerosene as a source of fuel in the household budget of the average worker. For the urban worker kerosene is used not only for lighting but sometimes as fuel for cooking among the white and blue collar single workers.
5. Generally most urban households use charcoal and/or firewood for cooking. The absence of adequate reforestation policies and the inefficiency of the crude carbonisation process used for producing charcoal have already been recognized as a threat to the natural sources of supply of firewood. Recent escalation in the price of kerosene and electricity have exerted an upward pressure on the demand for charcoal in the urban areas. The price per seventy-two pound bag of charcoal has risen from a 1977 range of \$4.50 to \$7.50 to a 1980 price of \$.70. With output of charcoal estimated annually at 250,000 tonnes, urban consumption is put at around 80-120,000

tonnes. On the basis of 2 bags of charcoal per month, the average household is estimated as spending some \$1,680 on charcoal per annum for cooking.

6. On the whole the rural population do not as a rule spend cash income on fuel for cooking. They use firewood which is often gathered from their farms.

Target Group:

7. Our investigation will attempt to identify the rural and urban target groups for the pyrolytic oil and char. The following areas will be explored:

	<u>Cooking</u>		<u>Lighting</u>	
	<u>Urban</u>	<u>Rural</u>	<u>Urban</u>	<u>Rural</u>
Oil	X	--	X	X
Char	X	--	--	--

8. Other applications of the products might be taken up at a second state if the primary objective of application of project products to raise living standards of the rural and urban lower income groups cannot be met for health and/or environmental reasons. Or the other applications might be considered after meeting the needs of the target group. The alternative uses of the oil might include its being substituted for residual fuel oil (bunker C mineral oil) for fuelling boilers for cottage industries. The gas might also be used to fuel a kiln dryer located close to a pyrolytic plant or to fuel a bakery.

Suggested Approach:

9. Before embarking on the field work involving evaluation of the suitability and acceptance of the char and oil as alternative and/or supplement to kerosene and charcoal, it was felt that some amount of laboratory work was necessary. A preliminary laboratory investigation has convinced us of the soundness of our proposed broader approach involving technical, economic and social evaluation.
10. The main thrust of the laboratory work is to -
- (a) analyse and evaluate the composition of the pyrolytic oil with a view of ascertaining the effects of its effluent fumes and gases on the environment and on animals. The preliminary findings may have implications

for the gas being burnt at the plant site and recommendations for protective clothing for workers. This work will precede the work under para (b) & (c) below as well as the social and economic aspects.

(b) Ascertain the suitability of the oil and char in their present form as substitutes of the oil and char in their present form as substitutes for charcoal and kerosene for heating and lighting using existing appliances.

(c) suggest modifications in the presentation of the char and oil and/or marginal adjustments in existing appliances (e.g. alternative wicks for lamps, briquetting of char, fractionation of oil and its dilution to yield more efficient and/or acceptable lighting oil).

11. Our preliminary laboratory investigation would seem to suggest the need for a broader approach involving initial laboratory work if such work has not already been done by Georgia Tech or elsewhere in the world. For the results of the laboratory work would seem to suggest that -

(a) the pyrolytic oil contains pyrene which is considered carcinogenic.

(b) the viscous tarry mass (the pyrolytic oil in its raw state) does not soak too readily on cotton wicks on which existing kerosene-based lighting and heating appliances depend.

(c) a component or constituent of the oil is soluble in water yielding a strongly acidic aqueous solution. An investigation or extraction of this corrosive solution might throw some light on how best to minimize the corrosive nature of the oil and/or lead to suggestions on the mode of storage and how best to maintain the durability of lighting and heating appliances.

(d) the oil residue left after stirring with water and extracting with other yields a considerably clean viscid oil after the removal of the other. The residue which appears to be insoluble in either exhibits consistency characteristic of coal tar, perhaps, even stiffer. There is reason to believe that, this viscid oil residue might be diluted with alcohol or some suitable solvent and used as a binder for the char into briquettes.

12. One the neutrality of the pyrolytic oil and its effluent fumes and gasses have been confirmed by the laboratory tests, the way would be clear for the introduction of the oil into homes to test its social acceptability (pungent smell) and its efficiency. The technical, economic and social evaluations will then proceed concurrently to -

- (a) assess the efficiency of oil and char as lighting and heating media
- (b) evaluate test calorific value of the charcoal to assist in coming out with pricing and indications through comparison with alternative fuel availabilities
- (c) assess the application and efficiency of oil as alternative and supplement to kerosene on existing wick-based lighting and heating appliances.
- (d) indicate pointers to improving the use of char and oil as heating and lighting media for the rural and urban lower income groups through possible fractionation of oil and better packaging (binding of char)
- (e) make recommendations for marginal modifications in existing appliances for facilitating the use and efficiency of the char and oil in their original form and/or in recommended modified forms.
- (f) ascertain the acceptability (in terms of prices and effect on environment - odour, fumes, etc.) of the resulting heating and lighting products (see para 12 (e) above) in homes. Three rural and three urban families will be picked for the impact analyses. Peoples' perception of the taste on food of char and oil cooking will be examined.
- (g) evaluate cost of alternative materials using char-coal/kerosene, pyrolytic oil/charcoal/kerosene equivalents (see para 12 (b) above) as established by laboratory analysis and by reference to the estimated market size for the products.

Equipment

- 13. It is our belief that there is a need to have continuous local capability for laboratory analysis of pyrolytic projects' output. There is a suspicion that close examination might be required due to expected variation in the composition of oils as different species of wood with different specific gravity and chemical composition are used as sawmills to produce sawdust for the pyrolytic process. Some input of laboratory equipment might be required. These range from gas liquid chromatograph to bomb calorimeter for distilling.
- 14. For the laboratory test fractionating the oil, and home tests there will be a need to purchase a few lighting and heating appliances.

The Team:

15. Our team of consultants will consist of -
 - (a) laboratory and technical tests including clinical test on effect of effluent gases of the oil on animals. The team will be led by Professor Tackie and Dr. Owusu.
 - (b) economic and social impact analysis. This aspect will be undertaken by A. Kwame Pianim economist and E. M. K. Aidam, engineer.
16. On the assumption that the laboratory work will have to be carried out in its entirety as outlined above then the cost implication might work out as indicated in the attached Table 1.

MEMORANDUM

TO: John Cooper USAID/Accra
FROM: Ray Kovac
DATE: Monday, August 4, 1980, 11:00 p.m.
RE: Social Soundness Analysis -- Proposal by Management and Investment Consultants, Ltd. -- Contacting Officer, Kwane Pianim

On Saturday, August 2, at our meeting in Accra I received a copy of the proposal for the Social Soundness Analysis associated with the pyrolytic conversion project. This letter will discuss the proposal, point by point, documenting the combined views we developed at our meeting, and adding information or ideas that have evolved in the last few days.

Point 1 N/A

Point 2 Identify and evaluate the social impact of the various applications in which pyrolytic products may be used to improve the living standards of the poor -- statement is too general. There are certainly many more applications of the pyrolysis products than we have discussed thus far, all of which will improve the living conditions of the poor and the economy of Ghana. There are also a number of industrial applications which will indirectly aid the poor. These applications show potential which can, and should be evaluated by future projects. This present project will extend through about the end of August, 1980. At that time the economic analysis, the Social Soundness Study, and a majority of the report should be completed. To provide for a timely and successful and conclusion to this project, the number of applications to be tested in the Social Soundness Analysis must necessarily be limited. The applications we favor at this point are the uses of charcoal or oil or some combination of the two, in one or several shapes (or forms), to be used in small (≈ 1 ft.³) cookers common in Ghana. The small grates (≈ 5 in. x 5in.) in the standard or average cooker have gaps which are too large to allow the use of dry, powdered charcoal. But the fuel must be prepared so that the standard cooker does not have to be modified or redesigned, that is, no additional expense will be borne by the people (other than the cost of the substitution, i.e. pyrolytic fuels).

Point 3 and 4 The use of kerosene by both urban and rural population for lighting. Some limited use of kerosene as a fuel for cooking. (The cost of kerosene was raised from 1¢ to \$3.50/gallon -- about \$0.36 to \$1.27 in December 1979. In contrast the minimum wage is ¢4.00/day or \$1.45/day).

The use of pyrolytic fuels as a substitute for kerosene for lighting and cooking is an application that shows potential and deserves future study. This is an example of an application which could be treated individually, as a relatively small investigation, or grouped with several similar applications to form a larger study. The kerosene lamp commonly used in Ghana is a small container with a handle similar to that of a beer mug, with two small holes in the lid. A piece of cotton or other fiber is twisted and placed in one hole while the other remains open. The pyrolytic oil will probably fail to operate properly in this type of lamp, without modification.

Point 5 and 6 Data

Point 7 Target Groups -- The investigation should be limited to the use of char and possibly oil for cooking. The choice of urban or rural environments, or both, are acceptable with the constraint that the individuals to do the testing must be selected, have ample time to test the products while maintaining the deadline of August 31 for the submission of the finished final report. There is not sufficient time to design and implement a program for the use of oil as a substitute for kerosene in urban or rural lighting. This subject should be handled separately.

Point 8 Other Applications -- The primary objective of the project is to explore the use of pyrolysis products to raise the living standards of lower income groups. There are other industrial applications which can be examined. Pyrolytic oil has been sold on a commercial basis for use as fuel in a cement kiln, a power boiler, and a lime kiln.^{10/} In the cement kiln, pyrolysis oil was fired as a 20% blend with #6 fuel oil. The oil was fired in parallel with several other burners using #6 fuel oil, in a power boiler. The pyrolytic oil was direct fired at the lime kiln. Prior to the industrial applications the oil was test fired in a Trans Thermal Vortex Burner and at KVB in a test boiler system.^{8/} A typical analysis of pyrolysis oil from pine bark and sawdust is:^{8/}

<u>Component</u>	<u>% By Weight</u>			
Carbon				49.4
Hydrogen				4.7
Oxygen				19.7
Nitrogen				0.16
Water				26.0
Ash				0.04
Density	9.88	to	10.27	lb./gal
HHV	9000	to	10,500	BTU/lb.

A number of companies in the U.S. are investigating the possibility of locating a pyrolysis plant within a sawmill. The convertors would use sawmill waste or residue as a feedstock. The pyrolysis products would be used to fuel a dry kiln. The convertor(s) would be sized to operate above base load conditions. The pyrolytic oil would be used to supplement the convertor gas production during peak load periods.

As the heat requirement of the dry kiln decreases, the convertor(s) can be "turned down" to produce less gas and more oil or charcoal (storable products).

All these "other applications" can be addressed in future projects but the present contract expires at the end of August, 1980. Therefore, there is not sufficient time to begin a study of alternative applications. However, a list (with short description of each) of the possible alternate applications of the pyrolysis process should be included to provide information and direction for future work.

Points 9, 10, 11 Primarily Focused on Laboratory Work

There is no need to include laboratory analysis in the proposed Social Soundness Analysis. The composition of the pyrolytic oil and gases as well as their combustion products has been determined and roughly 400 to 500 chemical compounds have been identified in the pyrolytic oil. There has been some work done on the carcinogenic nature of the oil by Gikis, et. al. ^{9/}, ^{10/}. A study on the extraction of pyrolytic oils, using various solvents and several processing schemes has been conducted by Knight, Elston, Hurst and Kovac.^{3/}

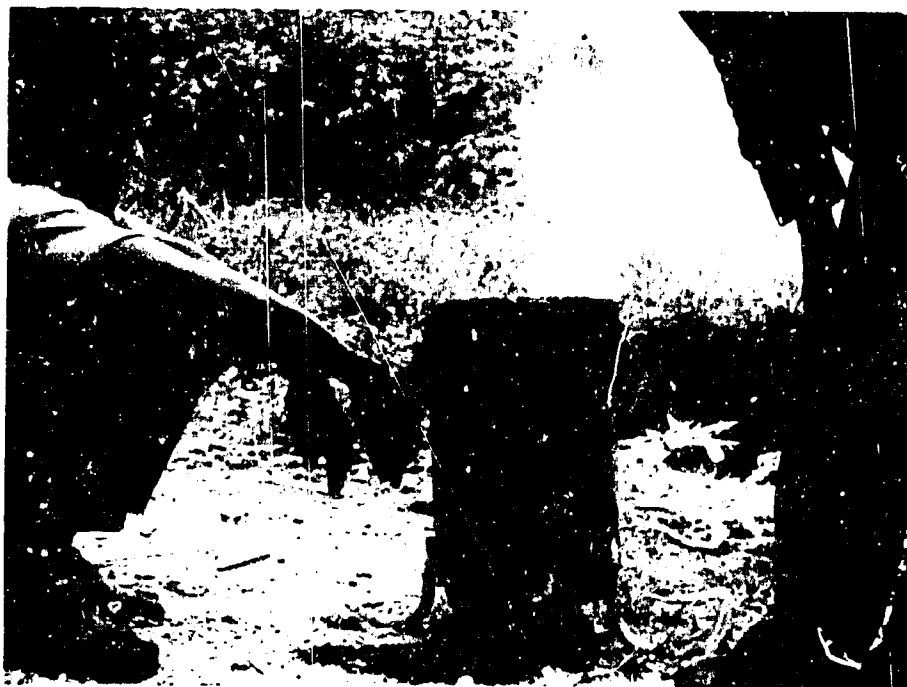

Figure F.1 (top left) Powder Char Cooker; Figure F.2 (top right) and Figure F.3 (bottom) Start-up.

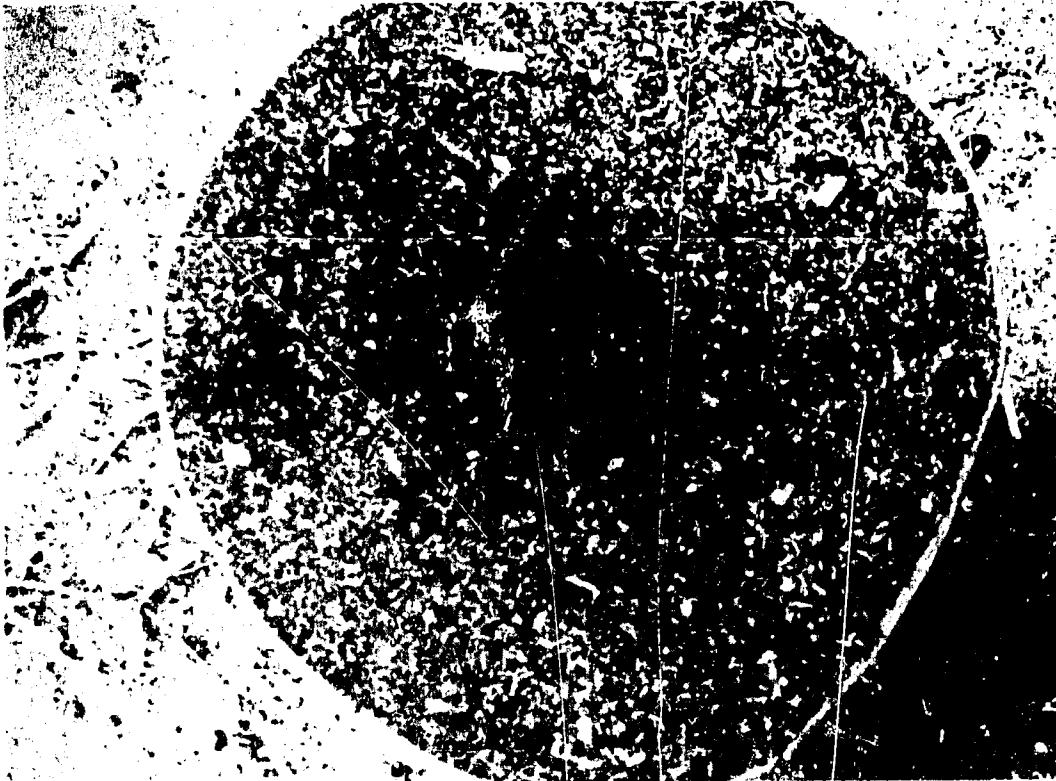

Figure F.4 (top) and Figure F.5 (bottom) Burning.

Protective clothing for pyrolytic plant employees (according to previous experience) includes long trousers (not shorts) and long-sleeved shirts--for protection from the heat as well as the oil. Cotton Clothing is Preferred Over Plastics and Synthetics. Cloth, leather or rubber gloves should be worn to protect the hands from hot metal, hot char or general wear and tear. Rubber gloves should be used when handling the oil. Closed shoes should be worn. Glasses or goggles are recommended when working near the operating equipment to protect the eyes from gases and from airborne particles.

Pyrolytic oil does not soak into cotton wicks and in general exhibits little or no capillary action. Its behavior more closely resembles a grease. The present cotton wicks used for lamps will have to be modified or replaced by an alternative.

The char produced by a pyrolytic convertor is usually powdery, flaky or granular, depending upon the feedstock. The char can be briquetted or used in its original form. The photo in Figure F.1 shows the cooker made by Mr. Opong which uses powdered, flaked char. A pipe or collar is welded to the bottom or near the bottom of the vessel to create a horizontal shaft. A pipe or piece of wood is placed in the top of the cooker vertically so that it touches the bottom of the pot and rests against (and perpendicular to) the collar. Char is then placed in the annular volume and tamped with a piece of wood to pack the char tightly. The vertical piece of wood or pipe is removed and some dried leaves or corn cob is placed at the base of the vertical shaft and lit with a match. After about 10 minutes the cooker produces enough heat to begin cooking, and it burns cleanly, i.e. without smoke. The cooker shown in the photos in Figures F.2, F.3, F.4, and F.5 was started at 10:00 a.m. and burned until about 5:30 p.m. At that time the cooker was about $\frac{1}{2}$ full with unburned char. The vessel was dumped and cleaned and taken home by the owner and prevent its untimely disappearance if left out overnight.

The char can be briquetted using a simple technique which was the result of a discussion with the pyrolysis employees.

A piece of wood such as a 2" x 4" or 4" x 4" is drilled through with a hole saw in several places. The size of the hole saw could be 1" to 2 $\frac{1}{2}$ ".

The holes in the wood provide the form for the charcoal briquettes. The drilled board is placed on a flat surface and the holes are filled with charcoal. The wooden cylinder removed from the board or a similar piece of wood is placed on the charcoal is compacted by hitting the wooden cylinder with a hammer or other heavy object. Additional charcoal can be placed in the form on top of the compacted charcoal and the above process repeated until a charcoal cylinder, or briquette of 2" to 3" in height is produced. A small quantity of oil can be poured on the charcoal in the form prior to compacting to serve as a binder. This oil would serve as a starter fluid for the charcoal.

The charcoal can also be briquetted using industrial briquetting machines. A number of U.S. companies were contacted to obtain information on briquetting equipment. Letters received from the two most promising responses are attached. K. R. Komarek Inc. manufactures two small capacity briquetting machines normally used in pilot plant work. The costs are \$38,600 and \$20,000. Both machines will produce about 500 to 1000 pounds per hour of dry charcoal briquettes. The less costly machine produces a smaller size briquette with a great operating cost. Figure F.6 shows the size comparison of the charcoal briquettes produced. Briquette A is the standard size U.S. charcoal briquette. Briquette B is approximately the size produced by the \$38,600 machine, while Briquette C is about the size of the briquettes produced by the \$20,000 machine. Fred S. Carver, Inc. manufactures a Preformer Press with a capacity of 25 tons for the price of \$18,900. The size of the briquette produced is 2" diameter and 1½" length.

None of the commercial briquetting machines seems to be appropriate for the pyrolysis system in Ghana. To make effective use of the capital investment in the briquetting machine, it should be operated continuously. If the Ghana pyrolysis system operated continuously for a month it would provide enough charcoal to operate the briquetting machines two or three days per month. Therefore, commercial briquetting should not be pursued. If the powdered charcoal had a selling price less than the lump charcoal presently used, the people would have the incentive to adapt to the powdered charcoal. When the powdered char was given to the pyrolysis

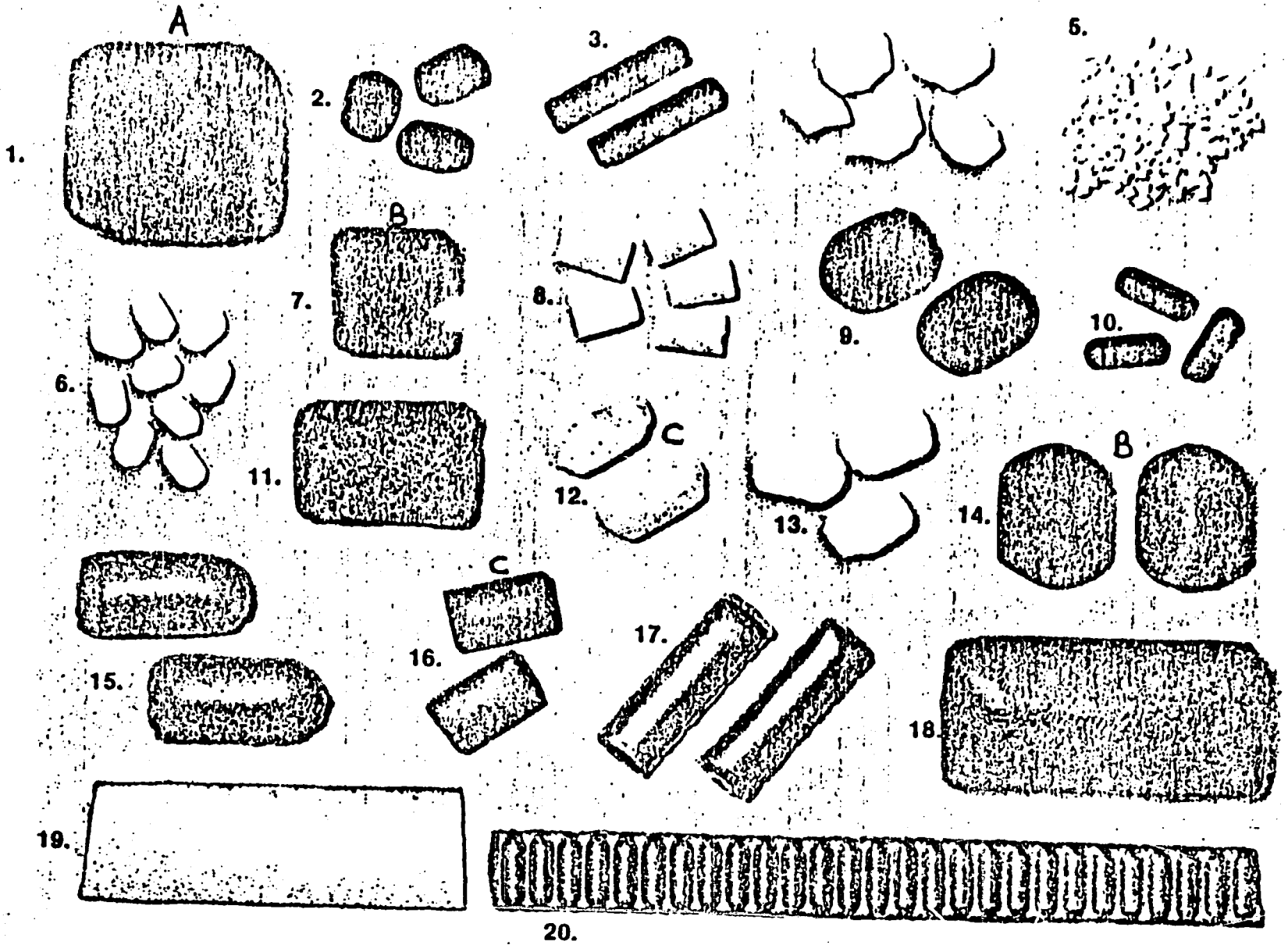

Figure F.6
Charcoal Briquettes

147

project employees at no cost, several of the cookers described earlier were fabricated by individual employees for home use.

Point 12

- a) Assess the efficiency of the char (and possibly the oil) as a cooling media only.
- b) The calorific value of the oil and charcoal have already been established.
- c) May be the basis for a future project.
- d&e) Fractionation of the oil is not necessary. The remaining items should be investigated.
- f) The main task of the study.
- g) May be done using published references for the physical properties of the materials.

K. R. KOMAREK INC.



EQUIPMENT AND SYSTEMS FOR BRIQUETTING AND COMPACTING

1825 ESTES AVENUE, ELK GROVE VILLAGE, ILLINOIS 60007

TEL 312-956-0060

TELEX 28-0588

KOMPAK ELGR

June 30, 1980

Georgia Institute of Technology
Engineering Experiment Station
Atlanta, Georgia 30392

Attn. Mr. Walter Kahres;

In response to your inquiry of June 22, I am enclosing a brochure which shows some of the machines we make. Our brochure also gives a brief description of the charcoal briquetting process as it is practiced in the United States.

Our Model No. B220-A briquet machine will be best for the purpose you describe. This machine has a base price of \$38,600.00 less motors and will produce 500 - 1000 lbs. per hour of dry charcoal briquets, somewhat smaller than those normally made in the United States. Our next smaller B150 can also be used but the briquet size will become quite small and roll costs per ton of product correspondingly greater. The B150 machine has a base price less motors of about \$20,000.00.

Drying of the briquet is a difficult part of the briquetting process and although we do not build driers, we have designed a drier for small plants which has been built locally and used successfully in Argentina. We will be glad to share this technology with you if you so wish.

Please call on us if you wish any additional information about our equipment or if we can in any way be of service.

Yours Truly,

K. R. Komarek

KRK/jls

Enclosures:



FRED S. CARVER INC.
HYDRAULIC EQUIPMENT

W142 N9050 FOUNTAIN BOULEVARD
MENOMONEE FALLS, WISCONSIN 53051
Phone: (414) 255-2540

June 27, 1980

Mr. Walter Kahres
GEORGIA INSTITUTE OF TECHNOLOGY
Engineering Experiment Station
Atlanta, GA 30332

Dear Mr. Kahres:

In response to your letter request of June 22nd, I am pleased to offer the following quotation on our 25 ton Preformer Press:

	<u>#2579</u>
Pressing Capacity	25 ton
Type	Table Model
Cyclic Rate	600/hour
Control Method	Electric, sequence
Hopper Capacity	1/2 cubic foot
Approx. Dimensions	64" L x 54" H
Weight	2,200 lbs.
Motor	15 HP
Pellet Size; (Standard Die Block)	2" D x 1-1/2" L
Pressure on Pellet; (Standard Die Block)	16,000 PSI
Volume of Pellet; (Standard Die Block)	4.7 cubic inch
Price; FOB Shipping Point	\$18,900.00

All Carver prices are FOB our plant and do not include any tax or charges incident to sale. Standard terms are net 30 days from date of invoice. Shipment of this press can be made in approximately 20-22 weeks after receipt of order. Price quoted is firm for sixty (60) days from date of quotation.

APPENDIX G
Calculation of Air to Feed Ratio

The attached graph is a calibration curve of the orifice plate used to measure the amount of air delivered to the reactor by the windjammer blowers. The curve shows the relation between the differential in pressure across the orifice, as measured by a magnehelic gauge, and the air flows in CFM.

In the past, a convertor had operated on as little as two bags of sawdust per hour. In present operation, four bags per hour is more the normal. Each bag weighs about 38 lbs. on a wet basis. The feed material at that time has a moisture content of about 7%, giving each bag a weight of 35.3 lbs. on a dry basis. The table below shows the amount of material fed to the reactor using two, three, or four bags.

At one time, normal operation for air flow to the reactor meant a Δp in the range 0.5 to 0.9 PSI.

<u>No. of Bags</u>	<u>Total Weigh of Feed Net Basis</u>	<u>Total Weight of Feed Dry Basis</u>	<u>Orifice Reading Δp</u>	<u>Air Flow CFM</u>	<u>Air Flow Lb./hr.</u>	<u>Air to Feed Ratio</u>
2	76	70.68	0.5	19.6	88.12	1.25
3	114	105.02	0.5	19.6	88.12	0.83
4	152	141.36	0.5	19.6	88.12	0.62

Since the highest figure on the calibration curve is 0.5 PSI, it will be used in the calculation. A Δp of 0.5 PSI corresponds to an air flow of 19.6 CFM. From physical property data, air has a density of 0.07493 lb. per cubic foot at 70°F and /ATM.

$$\frac{19.6 \text{ ft.}^3}{\text{min.}} \times \frac{0.07493 \text{ lb.}}{\text{ft.}^3} \times \frac{60 \text{ min.}}{\text{hour}} = 88.12 \frac{\text{lb.}}{\text{hour}} \text{ of air}$$

The air to feed ratio is calculated as follows:

$$A/F = \frac{\text{lb. air}}{\text{lb. feed - dry basis}}$$

The air to feed ratios for feed 2, 3, or 4 bags per hour to the reactor with an orifice reading of 0.5 are shown in the above table. Theoretical minimum A/F to sustain the pyrolysis reaction is about 0.25 lb. air per lb. feed. Converter have operated with A/F's in the range 0.27 to 0.50 lb. air per lb. feed. The above calculation shows that gasification was occurring during some past operations, with a corresponding drop in oil yield.

MAY 23 1980

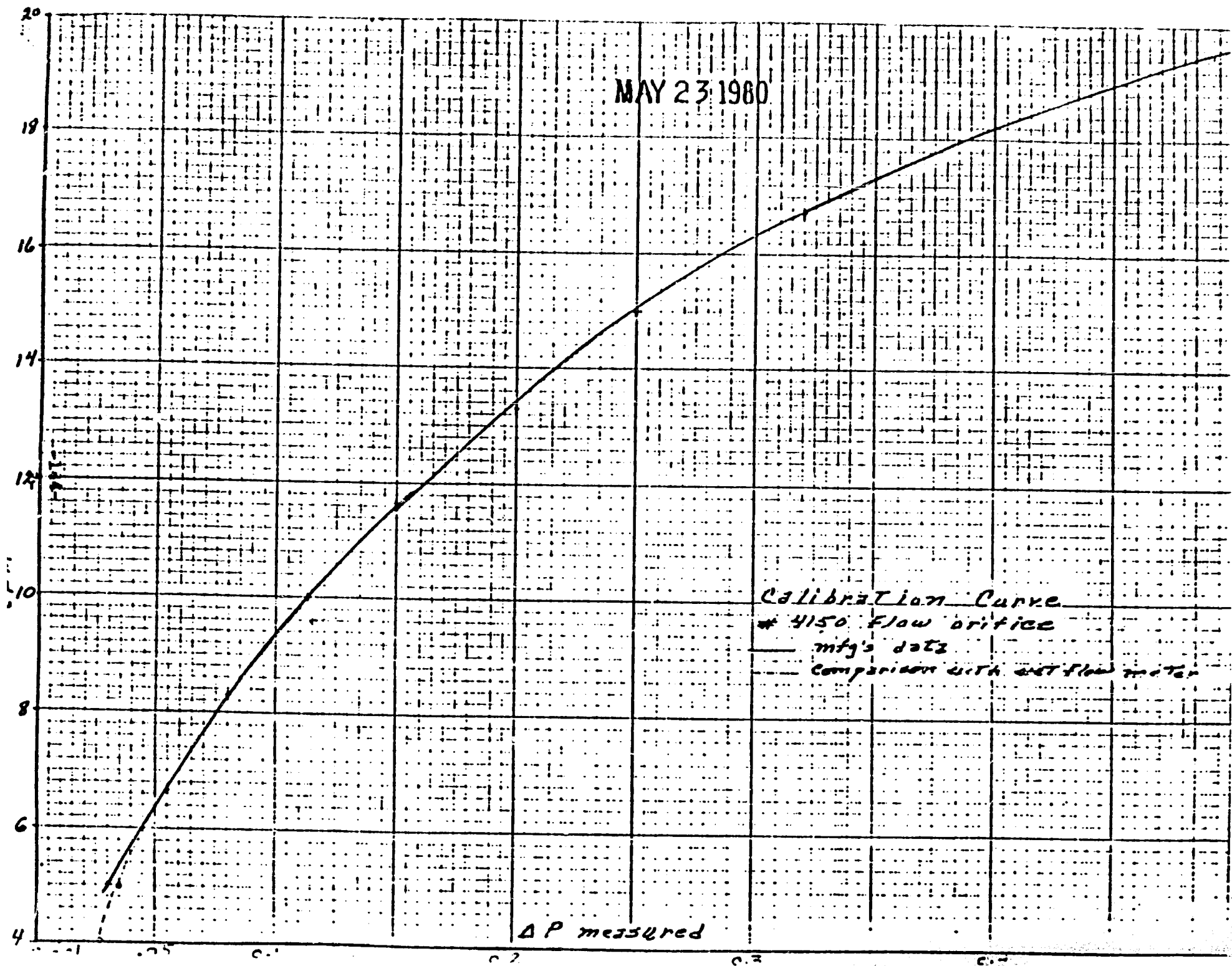

155

8.0 REFERENCES

1. Chiang, T. I., Tatom, J. W., de Graft-Johnson, J. W. S., Powell, J. W., "Pyrolytic Conversion Of Agricultural And Forestry Wastes In Ghana, A Feasibility Study". Final Report For Agency For International Development (AID), Office Of Science And Technology - (AID/ta-C-1290), Project A-1823, July 1976.
2. Knight, J. A., Hurst, D. R., and Elston, L. W., "Wood Oil from Pyrolysis of Pine Bark - Sawdust Mixture." in -- Fuels from Renewable Resources. D. A. Tillman, K. V. Sarkansen and L. L. Anderson, EDS. pp. 169-195, Academic Press, Inc., 1977.
3. Knight, J. A., Elston, L. W., Hurst, D. R., and Kovac, R. J., "Pyrolytic Oils - Characterization and Data Development for Continuous Processing" Final Report, March, 1980. Grant Nos. R-804416 and R-806403. U.S. Environmental Protection Agency, Cincinnati, Ohio 45268
4. Kaplan, I., McLaughlin, J. L., Marvin, B. J., Moeller, P. W., Nelson, H. D., and Whitaker, D. P., "Area Hand Book for Ghana." U.S. Government Printing Office, Document No. DA PAM 550-153, January 1971, pp. 21-23.
5. Moh, K., "First Progress Report On Demonstrating The Feasibility of Pyrolytic Conversion in Ghana." Progress Report For Project A-2076, April 1978.
6. Moh, K., "Ghana Trip report, Jan. 7, 1978 to March 25, 1978". Report On Progress Of Project A-2076, A Pyrolytic Conversion Demonstration in Ghana, April 1978.
7. Moh, K., and Potts, P. W., "Second Progress Report On Demonstrating The Feasibility Of Pyrolytic Conversion In Ghana." Progress Report For Project A-2076, October 1978.

8. Bowen, M. D., Smyly, E. D., Knight, J. A. and Purdy, K. R., "A Vertical - Bed Pyrolysis System," in Solid Wastes and Residues: Conversion by Advanced Thermal Processes. J. L. Jones and S. B. Radding, Eds., pp. 94-125. ACS Symposium Series 76, American Chemical Society, 1978.
9. Gikis, B. J., et al., "Preliminary Environmental Assessment of Energy Conversion Processes for Agricultural and Forest Product Residues." Volume I prepared by SRI International for EPA under Contract 68-01-2940 WA31, April 30, 1977.
10. Mission Analysis for the Federal Fuels from Biomass Program. Volume IV: Thermochemical Conversion of Biomass to Fuels and Chemicals, Report: January 1979. SRI International; Menlo Park, California, pp. 105-121.
11. Knight, J. A., "Pyrolysis of Pine Sawdust." in Thermal Uses and Properties of Carbohydrate and Lignins. F. Shafizadeh, K. V. Sarkanen and D. A. Tillman, Eds., pp. 159-173. Academic Press, Inc., 1976.